

*Phase leg
MOSFET Power Module*

$V_{DSS} = 200V$
 $R_{DSon} = 5m\Omega$ max @ $T_j = 25^\circ C$
 $I_D = 333A$ @ $T_c = 25^\circ C$

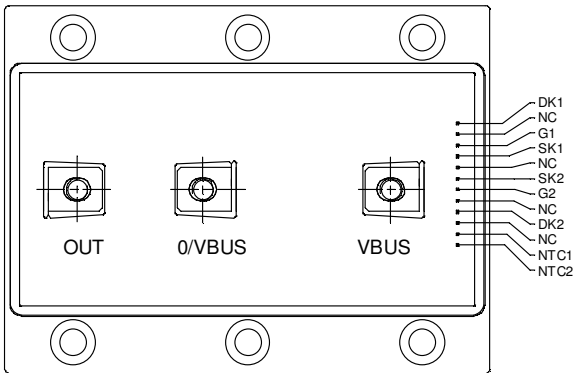
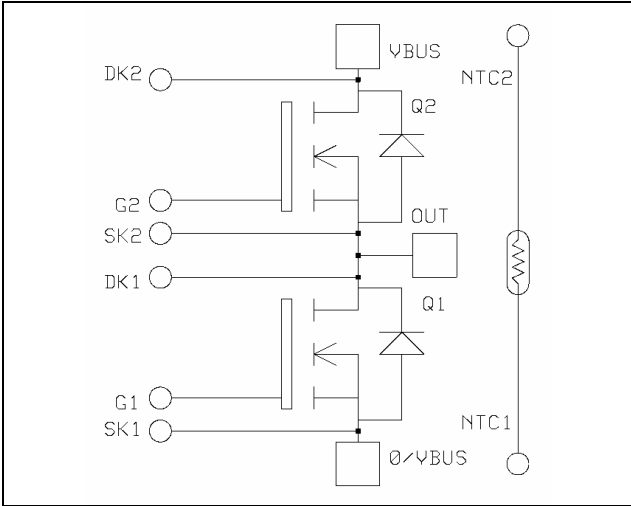

Application

- Welding converters
- Switched Mode Power Supplies
- Uninterruptible Power Supplies
- Motor control

Features

- Power MOS V® FREDFETs
 - Low R_{DSon}
 - Low input and Miller capacitance
 - Low gate charge
 - Fast intrinsic diode
 - Avalanche energy rated
 - Very rugged
- Kelvin source for easy drive
- Kelvin Drain for VDS monitoring
- Very low stray inductance
 - Symmetrical design
 - M5 power connectors
- Internal thermistor for temperature monitoring
- High level of integration

Benefits

- Outstanding performance at high frequency operation
- Direct mounting to heatsink (isolated package)
- Low junction to case thermal resistance
- Solderable terminals for signal and M5 for power for easy PCB mounting

Absolute maximum ratings

Symbol	Parameter	Max ratings	Unit
V_{DSS}	Drain - Source Breakdown Voltage	200	V
I_D	Continuous Drain Current	$T_c = 25^\circ C$	333
		$T_c = 80^\circ C$	249
I_{DM}	Pulsed Drain current	700	
V_{GS}	Gate - Source Voltage	± 30	V
R_{DSon}	Drain - Source ON Resistance	5	m Ω
P_D	Maximum Power Dissipation	$T_c = 25^\circ C$	1250
I_{AR}	Avalanche current (repetitive and non repetitive)	333	A
E_{AR}	Repetitive Avalanche Energy	30	mJ
E_{AS}	Single Pulse Avalanche Energy	1300	

CAUTION: These Devices are sensitive to Electrostatic Discharge. Proper Handling Procedures Should Be Followed.

Electrical Characteristics

All ratings @ $T_j = 25^\circ\text{C}$ unless otherwise specified

Symbol	Characteristic	Test Conditions	Min	Typ	Max	Unit
BV_{DSS}	Drain - Source Breakdown Voltage	$V_{GS} = 0V, I_D = 1mA$	200			V
I_{DSS}	Zero Gate Voltage Drain Current	$V_{GS} = 0V, V_{DS} = 200V$			1000	μA
		$V_{GS} = 0V, V_{DS} = 160V$			2500	
$R_{DS(on)}$	Drain - Source on Resistance	$V_{GS} = 10V, I_D = 166.5A$			5	$m\Omega$
$V_{GS(th)}$	Gate Threshold Voltage	$V_{GS} = V_{DS}, I_D = 8mA$	2		4	V
I_{GSS}	Gate - Source Leakage Current	$V_{GS} = \pm 30V, V_{DS} = 0V$			± 250	nA

Dynamic Characteristics

Symbol	Characteristic	Test Conditions	Min	Typ	Max	Unit
C_{iss}	Input Capacitance	$V_{GS} = 0V$ $V_{DS} = 25V$ $f = 1MHz$		40.8		nF
C_{oss}	Output Capacitance			9.1		
C_{rss}	Reverse Transfer Capacitance			3.1		
Q_g	Total gate Charge	$V_{GS} = 10V$ $V_{Bus} = 100V$ $I_D = 333A$		1184		nC
Q_{gs}	Gate - Source Charge			376		
Q_{gd}	Gate - Drain Charge			600		
$T_{d(on)}$	Turn-on Delay Time	Resistive Switching $V_{GS} = 15V$ $V_{Bus} = 100V$ $I_D = 333A$ $R_G = 0.22 \Omega$		15		ns
T_r	Rise Time			25		
$T_{d(off)}$	Turn-off Delay Time			50		
T_f	Fall Time			10		

Source - Drain diode ratings and characteristics

Symbol	Characteristic	Test Conditions	Min	Typ	Max	Unit	
I_S	Continuous Source current (Body diode)		$T_c = 25^\circ\text{C}$			333	A
			$T_c = 80^\circ\text{C}$			249	
V_{SD}	Diode Forward Voltage	$V_{GS} = 0V, I_S = -333A$			1.3	V	
dv/dt	Peak Diode Recovery ①				8	V/ns	
t_{rr}	Reverse Recovery Time	$I_S = -333A$ $V_R = 100V$ $di_S/dt = 800A/\mu s$	$T_j = 25^\circ\text{C}$			240	ns
			$T_j = 125^\circ\text{C}$			420	
Q_{rr}	Reverse Recovery Charge	$I_S = -333A$ $V_R = 100V$ $di_S/dt = 800A/\mu s$	$T_j = 25^\circ\text{C}$		8		μC
			$T_j = 125^\circ\text{C}$		16		

① dv/dt numbers reflect the limitations of the circuit rather than the device itself.

$$I_S \leq -333A \quad di/dt \leq 700A/\mu s \quad V_R \leq V_{DSS} \quad T_j \leq 150^\circ\text{C}$$

Thermal and package characteristics

Symbol	Characteristic	Min	Typ	Max	Unit	
R _{thJC}	Junction to Case			0.1	°C/W	
V _{ISOL}	RMS Isolation Voltage, any terminal to case t = 1 min, I _{isol} < 1mA, 50/60Hz	2500			V	
T _J	Operating junction temperature range	-40		150	°C	
T _{STG}	Storage Temperature Range	-40		125		
T _C	Operating Case Temperature	-40		100		
Torque	Mounting torque	To heatsink	M5	2	3.5	N.m
		For terminals	M5	2	3.5	
Wt	Package Weight			550	g	

Temperature sensor NTC

Symbol	Characteristic	Min	Typ	Max	Unit
R ₂₅	Resistance @ 25°C		68		kΩ
B _{25/85}	T ₂₅ = 298.16 K		4080		K

$$R_T = \frac{R_{25}}{\exp \left[B_{25/85} \left(\frac{1}{T_{25}} - \frac{1}{T} \right) \right]}$$

T: Thermistor temperature
R_T: Thermistor value at T

Package outline

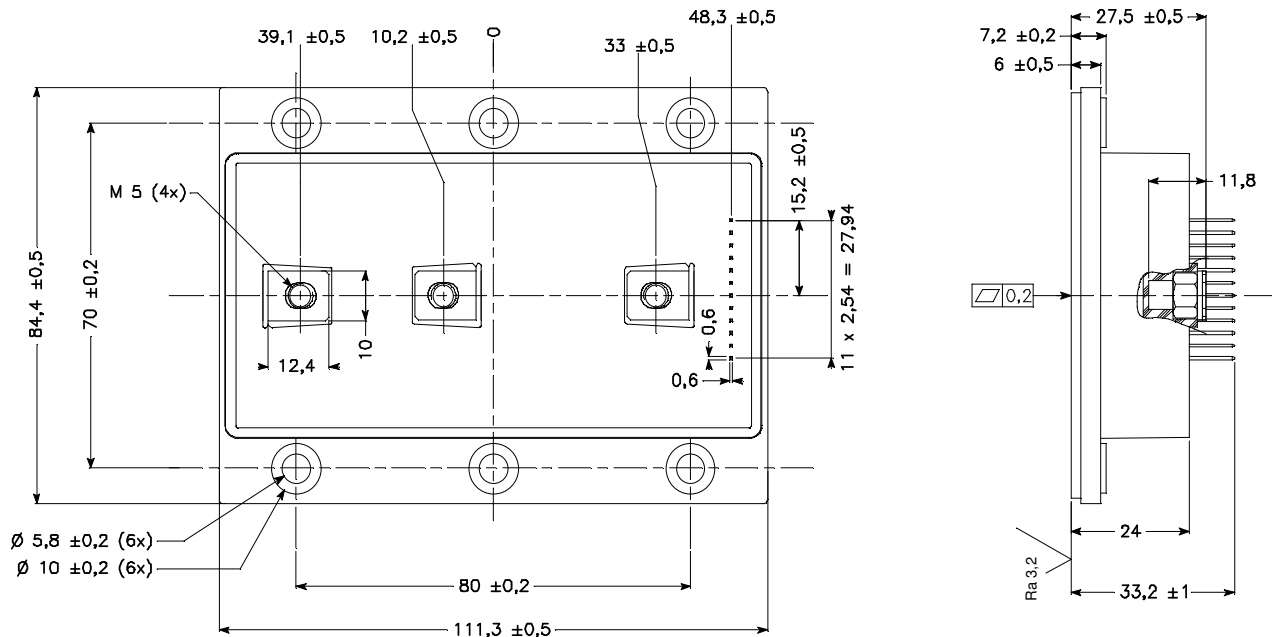

APT reserves the right to change, without notice, the specifications and information contained herein

APT's products are covered by one or more of U.S. patents 4,895,810 5,045,903 5,089,434 5,182,234 5,019,522 5,262,336 6,503,786 5,256,583 4,748,103 5,283,202 5,231,474 5,434,095 5,528,058 and foreign patents. U.S and Foreign patents pending. All Rights Reserved.