

DIN-Power F032FW-22,0C1-2

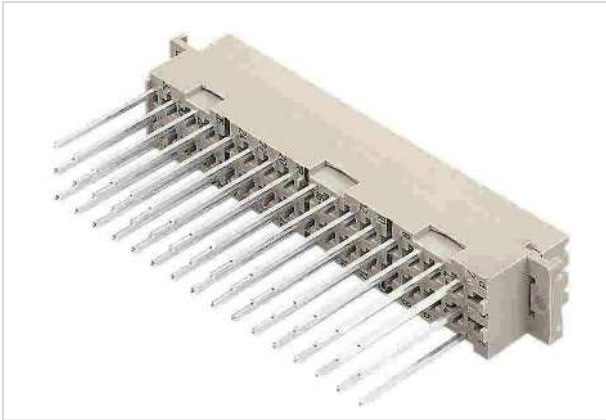

Image is for illustration purposes only. Please refer to product description.

| | |
|--------------------|---|
| Part number | 09 06 232 2821 |
| Specification | DIN-Power F032FW-22,0C1-2 |
| HARTING eCatalogue | https://b2b.harting.com/09062322821 |

Identification

| | |
|----------------------------|------------------|
| Category | Connectors |
| Series | DIN 41612 |
| Identification | Type F |
| Element | Female connector |
| Description of the contact | Straight |
| Features | lead-free |

Version

| | |
|-----------------------|---|
| Termination method | Wrap termination |
| Connection type | PCB to cable Cable to cable |
| Number of contacts | 32 |
| Contact configuration | Rows z and b, positions 2, 4, ... , 30, 32 |
| Termination length | 22 mm |
| Coding | Hole coding Coding with loss of contacts |
| PCB fixing | With fixing flange |

Technical characteristics

| | |
|-------------------------------|---|
| Contact rows | 3 |
| Contact spacing (mating side) | 3.81 mm 5.08 mm |
| Rated current | 6 A |
| Rated current | Rated current measured at 20 °C, see derating curve for details |



Pushing Performance
 Since 1945

Technical characteristics

| | |
|----------------------------------|--|
| Clearance distance | ≥1.6 mm |
| Creepage distance | ≥3 mm |
| Insulation resistance | >10 ¹² Ω |
| Contact resistance | ≤15 mΩ |
| Limiting temperature | -55 ... +125 °C |
| Insertion and withdrawal force | ≤50 N |
| Performance level | 1 acc. to IEC 60603-2 |
| Mating cycles | ≥500 |
| Test voltage U _{r.m.s.} | 1.55 kV (contact-contact) 2.5 kV (contact-ground) |
| Isolation group | IIIa (175 ≤ CTI < 400) |
| Hot plugging | No |

Material properties

| | |
|---|--|
| Material (insert) | Thermoplastic resin, glass-fibre filled |
| Colour (insert) | RAL 7032 (pebble grey) |
| Material (contacts) | Copper alloy |
| Surface (contacts) | Noble metal over Ni Mating side Ni Termination side |
| Material flammability class acc. to UL 94 | V-0 |
| RoHS | compliant |
| ELV status | compliant |
| China RoHS | e |
| REACH Annex XVII substances | Not contained |
| REACH ANNEX XIV substances | Not contained |
| REACH SVHC substances | Not contained |
| California Proposition 65 substances | Yes |
| California Proposition 65 substances | Antimony trioxide Nickel |
| Fire protection on railway vehicles | EN 45545-2 (2020-08) |
| Requirement set with Hazard Levels | R26 |

Specifications and approvals

| | |
|----------------|-------------|
| Specifications | IEC 60603-2 |
|----------------|-------------|



Pushing Performance
Since 1945

Specifications and approvals

UL / CSA UL 1977 ECBT2.E102079
CSA-C22.2 No. 182.3 ECBT8.E102079

Railway classification F4/I3 acc. to NFF 16-101/102

Commercial data

| | |
|--------------------------------|--|
| Packaging size | 20 |
| Net weight | 32.96 g |
| Country of origin | Germany |
| European customs tariff number | 85366990 |
| GTIN | 5713140013100 |
| eCl@ss | 27460201 PCB connector (board connector) |

Current carrying capacity

The current carrying capacity of the connectors is limited by the thermal load capability of the contact element material including the connections and the insulating parts. The derating curve is therefore valid for currents which flow constantly (non-intermittent) through each contact element of the connector evenly, without exceeding the allowed maximum temperature.
Measuring and testing techniques acc. to IEC 60512-5-2

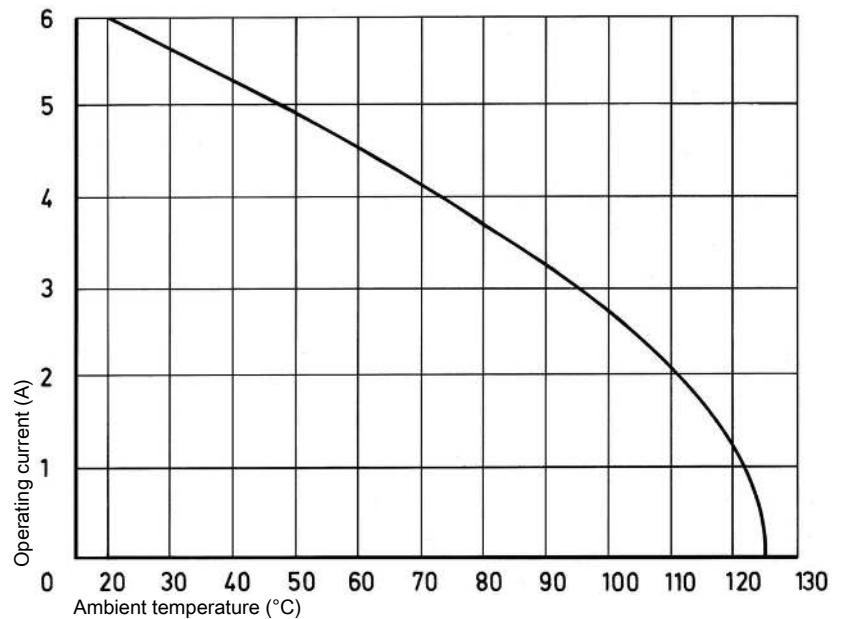

Hole coding (without loss of contact)

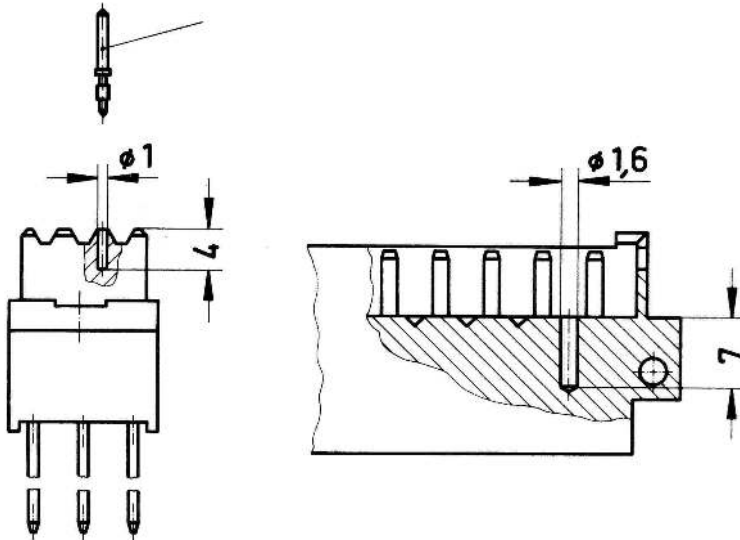

To avoid cross-plugging of adjacent connectors a coding system is required.
Drill out the male connector at pre-centered point according to the sketch. Use the setting tool 09 99 000 0103 to insert the coding pin 09 06 000 9950 into the existing hole in the female connector.

Coding with loss of contacts

To avoid cross-plugging of adjacent connectors a coding system is required.

The coding is achieved by means of a code pin which is inserted into the selected chamber of the female connector (the contact cavity must be filled with a female contact!).

The opposite male contact must be removed with the help of the specially designed tool. It's recommended to use at least 3 pins.

Coding pin 09 04 000 9908

Removal tool for male contacts 09 99 000 0038

Mating conditions

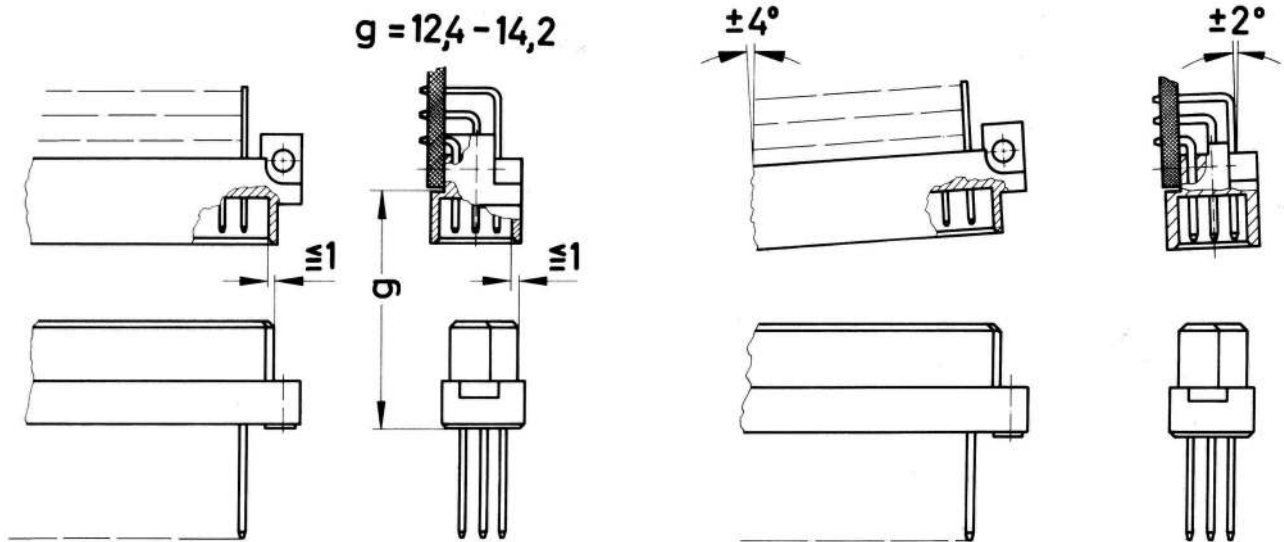

To ensure reliable connections and prevent unnecessary damage, please refer to the application data diagrams. These recommendations are set out in IEC 60603-2. The connectors should not be coupled and decoupled under electrical load.