

SECTION A-A

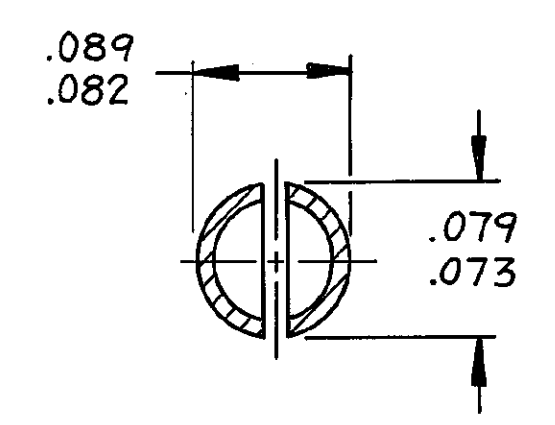

SECTION B-B
SCALE 10:1

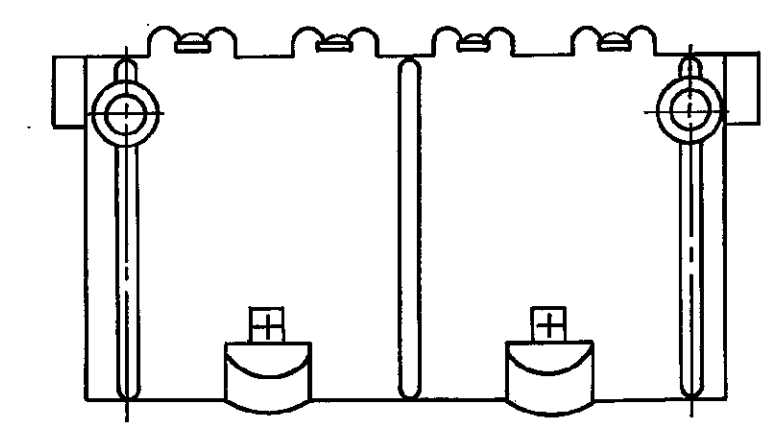
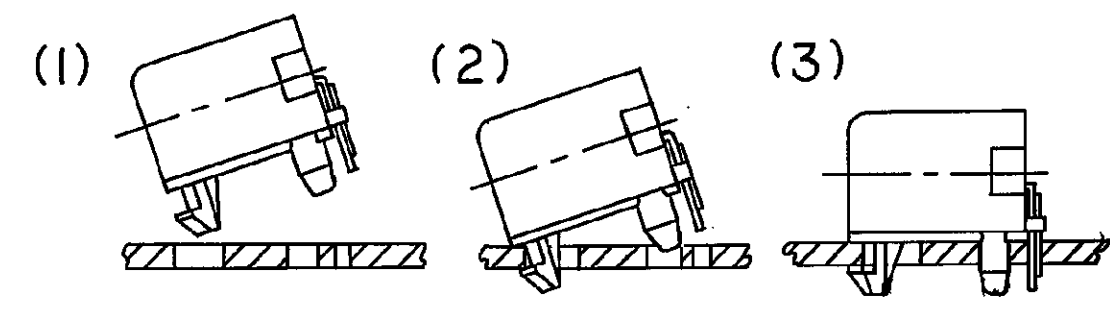

MOUNTING PROCEDURE

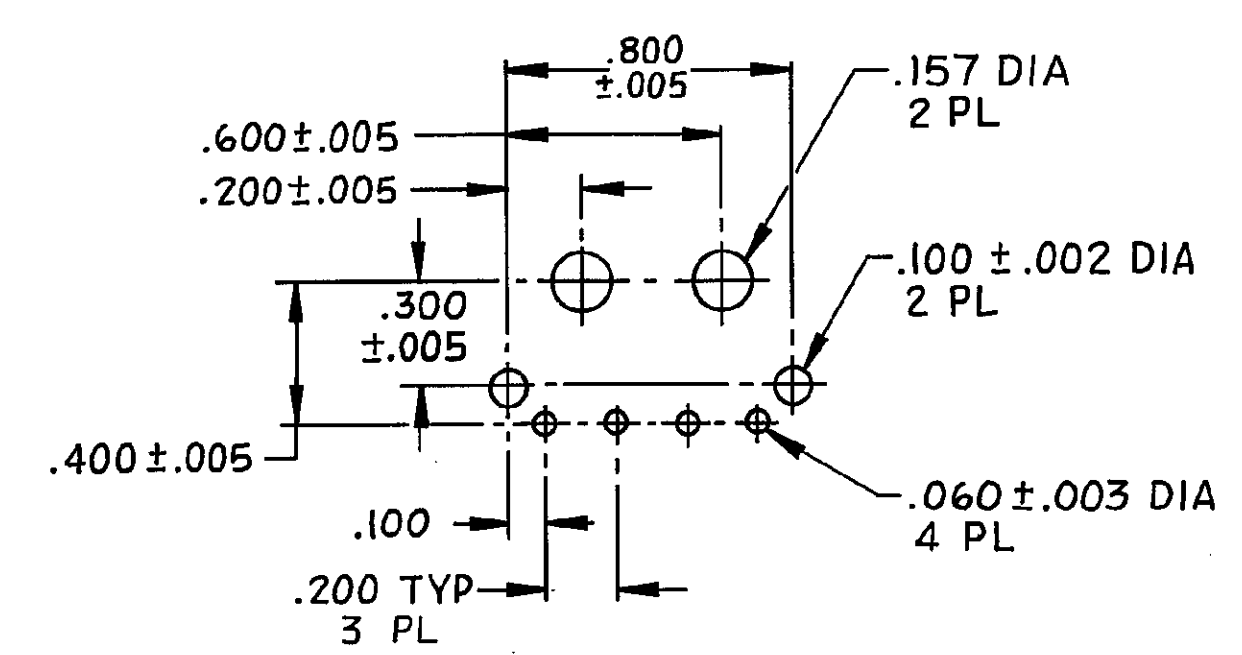

RECOMMENDED LAYOUT
FOR .062 THK P.C. BOARD
SCALE 2-1

- PARTS COMPLY WITH AMP SOLDERABILITY SPEC 109-II-3.
- RECOMMENDED EXPOSURE TO SOLDER WAVE (490°F) NOT TO EXCEED 5 SECONDS.
- MATERIAL - HOUSING: NYLON UL94V-2 (NATURAL).
CONTACT: PHOS BRONZE (PRE-TIN).
- MATERIAL - HOUSING: NYLON UL94V-0 (WHITE).
CONTACT: PHOS BRONZE (PRE-TIN).
- DIMENSION SHOWN REPRESENT PRODUCT IN DRY CONDITION. ADDITIONAL 2% GROWTH DUE TO END USE LOCATION MOISTURE ABSORPTION MAY OCCUR AND SHOULD BE ACCOUNTED FOR.

UNLESS OTHERWISE SPECIFIED DIMENSIONS ARE IN INCHES. TOLERANCES ON: DECIMALS ± .015 ANGLES ± .015		CONTRACT NO. DR <i>6-27-84</i>		FINISH		MATERIAL		PART NO.	
SEE TABLE		DR <i>6-29-84</i>		TE Connectivity		1-641737-1		641737-1	
SEE TABLE		DR <i>6-29-84</i>		NAME		P.C. HEADER, RIGHT ANGLE MOUNT, COMMERCIAL MATE-N-LOK, 4 CKT			
FINISH		OTHER APPD		SIZE		FSCM NO		DRAWING NO	
SEE TABLE				D		00779		641737	
				SCALE 4-1		SHEET			