



Midas Touch

magic embedded

We are dedicated to developing sensing technology, and providing customers with an innovative and diverse range of sensor products.

Our sensors and state-of-the art fingerprint recognition algorithm technologies provide advanced and convenient fingerprint acquisition and verification.

## MFC-1082 Fingerprint Image Sensor Data Sheet

### Midas Touch, Inc.

17F-16, No. 1, Sec. 1, Zhongshan Rd., Banqiao Dist.,  
New Taipei City 22083, Taiwan (R.O.C.)

Email: [support@midastouchinc.com](mailto:support@midastouchinc.com)

Tel : +886-2-8953-0862

Fax : +886-2-2952-8441



### [DESCRIPTION]

MFC-1082 is designed for capacitive touch coating or ceramics-covered fingerprint sensor. Flexible LGA package design, suitable 9~12Φ roundness or square shape module design. Passive mode, single chip architecture, without any external drive signal or chip, simplify the module design. It could be assembled as metal ring, decorative ring and ring less program.

Chip is built-in hardware anti-noise architecture design. In charging mode, automatic frequency hopping mechanism, greatly enhance the experience if a charger is used.

### [FEATURES]

- 88 x 62 pixels (508DPI)
- Build-in ADC for digitizing image
- High speed SPI interface
- High identification rate
- Short read out time

### [APPLICATIONS]

- Door lock
- Security device
- Smart card

### [SPECIFICATIONS]

Item	Value
Sensing area	4.4 mm x 3.1 mm
Package shape	Square or Roundness(Min. 9-Φ, Max. 12-
Package size	Min. 6.5 x 8.6 mm , Max. 12 x 12
Package thickness	0.65
System operating voltage	2.6 V ~ 3.6V AVDD
Total supply current	9 mA
Operating temperature	-40 to +85 °C
Interface	SPI (12Mbps)



## Table of Contents

<b>1</b>	<b>Architecture</b> .....	<b>4</b>
1.1	Block Diagram .....	4
<b>2</b>	<b>Pin Assignment</b> .....	<b>5</b>
2.1	Pin Assignment .....	5
2.2	Pin Description .....	6
2.3	Application Schematic .....	7
<b>3</b>	<b>Electrical Characteristics</b> .....	<b>9</b>
3.1	Recommended Operating Conditions .....	9
3.2	Absolute Maximum Ratings .....	9
3.3	DC Characteristics .....	10
3.4	Communication Protocol .....	10
3.4.1	Power- On Timing .....	11
3.4.2	SPI Timing .....	12
3.4.3	Operating Modes .....	13
3.4.4	Image Capture Modes .....	13
3.4.5	Finger Wakeup Mode .....	13
<b>4</b>	<b>Package Information</b> .....	<b>14</b>
4.1	Package Information .....	14
<b>5</b>	<b>Revision history</b> .....	<b>16</b>



# 1 Architecture

## 1.1 Block Diagram

MFC-1082 mainly consists of 4 blocks, namely, Sensor array, Front-end, PMU, Peripherals (Touch Key、Communication and Controller MCU)。The sensor array is composed of the sensing element of resolution 508ppi. 508ppi sensor array. And the corresponding data and finger state are obtained through the measurement of the front-end circuit. The MCU communicates with the Host side and switches between different modes. The main mode is image capture and finger wake-up.

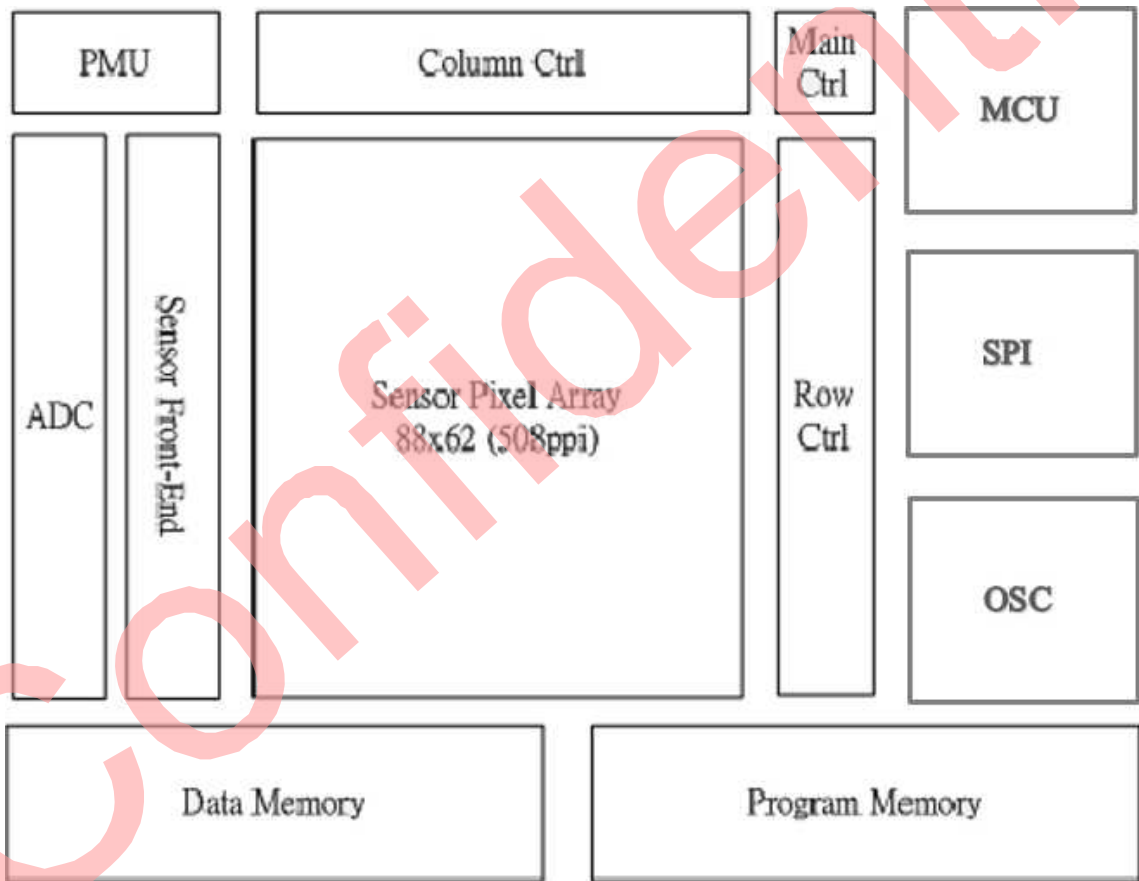



## 2 Pin Assignment

### 2.1 Pin Assignment

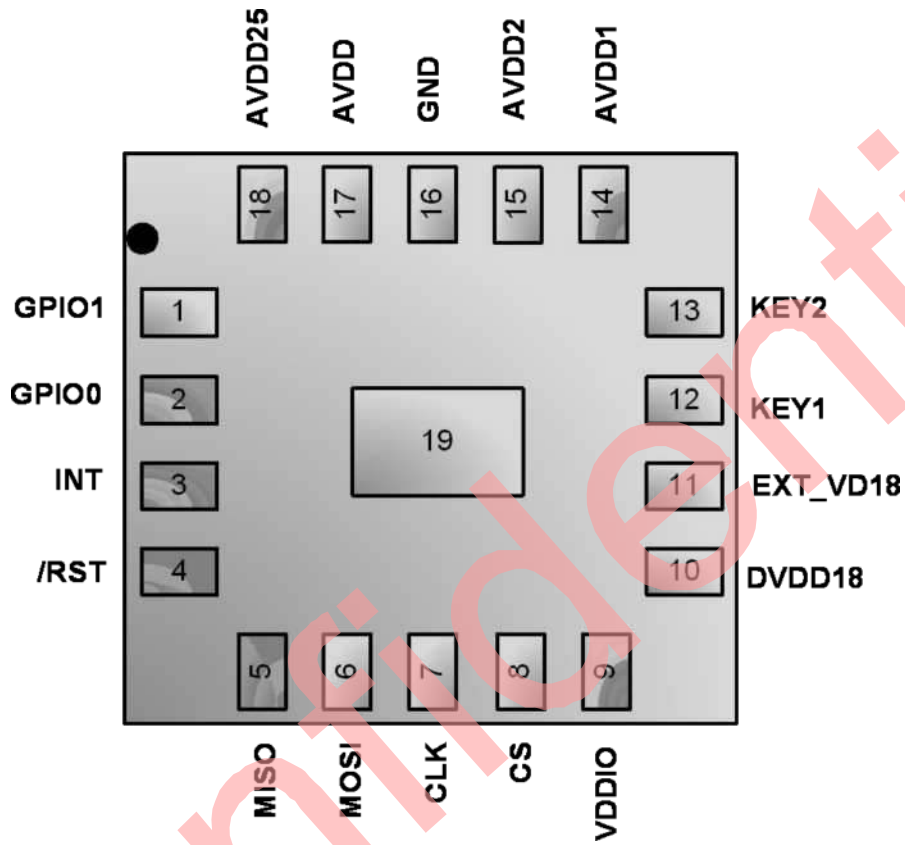



## 2.2 Pin Description

Pin Name	Type	Pin Description
GPIO1	1	General propose I/O. Vendor ID check.
GPIO0	2	General propose I/O. Vendor ID check.
INT	3	Interrupt signal
RSTB	4	Reset input (active-low)
MISO	5	SPI data signal output (to Host)
MOSI	6	SPI data signal input
CLK	7	SPI clock signal
CS	8	SPI chip select signal
VDDIO	9	I/O power supply, external 1uF capacitor to GND; if VDDIO is connected to AVDD, the I/O supply voltage is AVDD; if VDDIO is left floating, the I/O supply voltage is 1.8V.
DVDD18	10	Internal power output, external 1uF capacitor to GND If EXT_VD18 is pulled to AVDD, DVDD18 need to be used external 1.8V power source.
EXT_VD18	11	DVDD18 source control If EXT_VD18 is pulled to AVDD, DVDD18 need to be used external 1.8V power source. If EXT_VD18 is pulled to GND or floating, DVDD18 would be internal regulator output.
KEY0	12	NC.
KEY1	13	NC.
AVDD1	14	Power input, external 1uF capacitor to GND.
AVDD2	15	Power input, external 1uF capacitor to GND.
GND	16	System Ground
AVDD	17	Power input, external 1uF capacitor to GND.
AVDD25	18	Internal power output, external 1uF capacitor to GND
GND	19	System Ground





### 2.3.1 Ring-less, Ring Key Design

MFC-1082 can be Ring-less or with decorative ring. The shape and material of the decorative ring is subject to specific project requirements. If the ring is made of metallic material, it is recommended to be grounded.

In addition, the ring can serve as part of the touch key. The major function of the ring key is to expand the active area of the touch key so that both the ring and the pixel area can respond to the touch-up and touch-down events.

Solution 1: No Ring or Decorative Ring (nonfunctional)

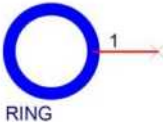

The shape and material of the Ring are subject to project requirements. If the Ring is metallic, it is recommended to be grounded.





### 3 Electrical Characteristics

#### 3.1 Recommended Operating Conditions

Parameter	Min.	Typ	Max.	Unit
AVDD	2.65	2.8/3.0/3.3	3.6	V
DVDD18	1.71	1.8	1.89	V
Operating temperature	-40	+25	+85	°C

#### 3.2 Absolute Maximum Ratings

Parameter	Min.	Max.	Unit
AVDD/AVDD1/AVDD2	-0.3	4.2	V
VDDIO	-0.3	4.2	V
DVDD18	-0.3	1.98	V
Voltage on digital I/O	-0.3	4.2	V
Storage temperature	-40	+125	°C
ESD susceptibility (HBM)	-4	+4	KV



### 3.3 DC Characteristics

Operating Conditions: AVDD=3.3V, VDDIO=3.3V, 25 °C

Symbol	Parameter	Conditions	MIN	TYP	MAX	Unit
	Image Capture Mode average current	@10Hz		19		mA
	Finger WakeUp Mode average current	@20Hz		2		mA
Digital inputs						
V <sub>IH</sub>	High level input voltage		0.75*VDD			V
V <sub>IL</sub>	Low level input voltage				0.25*VDD	V
Digital outputs						
V <sub>OH</sub>	High level output voltage	I <sub>OH</sub> = 0.25mA		0.8*VDD		V
V <sub>OL</sub>	Low level output voltage	I <sub>OL</sub> = 0.25mA		0.2	0.5	V
	RSTB active low voltage	IO=AVDD		1.35		V
	RSTB active low voltage	IO=1.8V		0.6		V

### 3.4 Communication Protocol

MFC-1082 communicates with the Host via SPI interface which only supports CPOL=0 and CPHA=0. Communication with the Host is performed by MOSI (SPI interface slave data in), MISO (SPI interface slave data out), CLK (SPI clock) and CS (SPI chip select). MFC-1082 always serves as the slave device, with all communication being initialized by the Host. The length of the transmission will be controlled by the software within the flexible control, the longest can be transferred to 4K bytes of data length.



### 3.4.1 Power- On Timing

After power on, the Host needs to control the pins of MFC-1082, such as AVDD, RSTB, INT and SPI bus, according to the timing diagram shown in below.

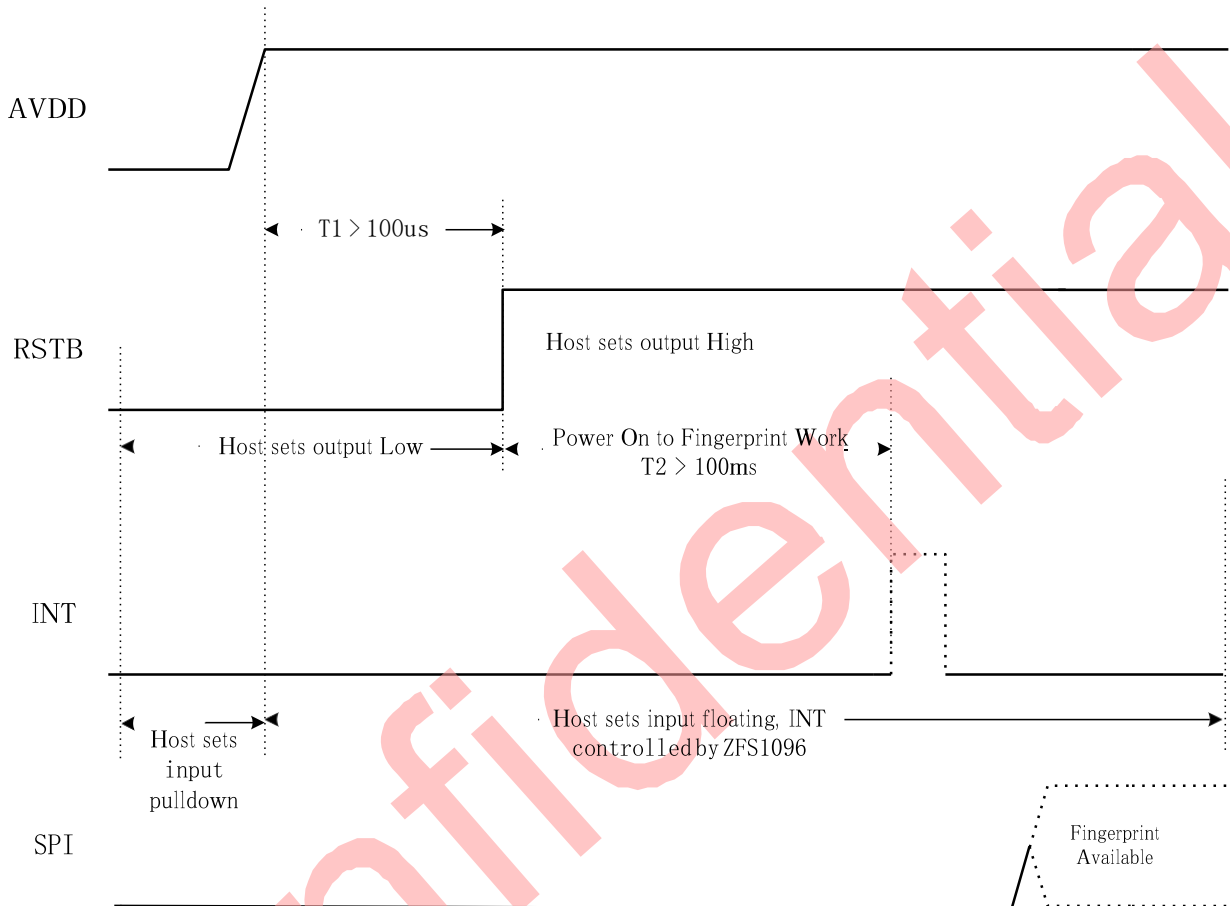



### 3.4.2 SPI Timing

MFC-1082 from the fingerprint module, the host can communicate with MFC-1082 at a high speed, typically, 12Mbps. Please note the SPI bus can implement high-speed transmission only when host is reading fingerprint raw data or registers.

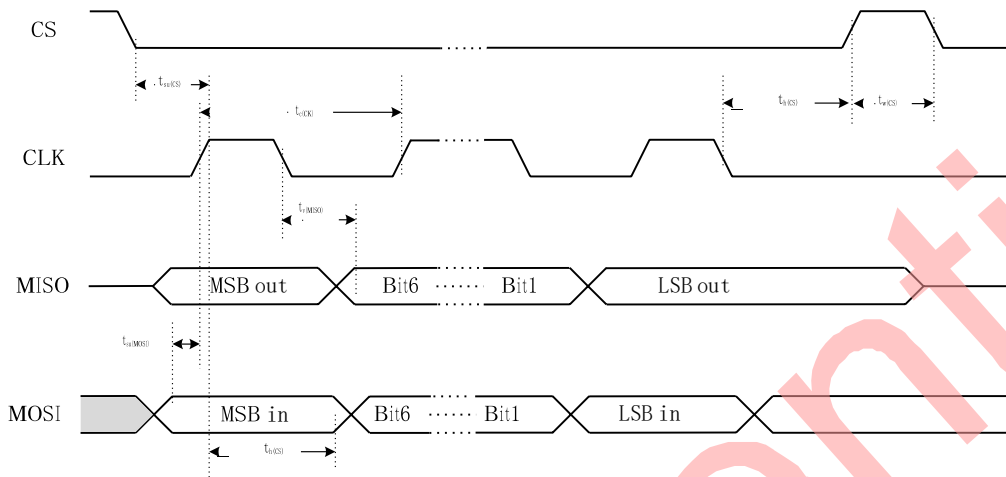

Symbol	Description	Min.	Typ.	Max.	Unit
$1/t_c(CLK)$	SPI clock speed		12	16	MHz
$t_{su}(CS)$	SPI CS setup time	40			ns
$t_h(CS)$	SPI CS hold time	10			ns
$t_w(CS)$	SPI CS idle time	320			ns
$t_{su}(MOSI)$	MOSI setup time	30			ns
$t_h(MOSI)$	MOSI hold time	30			ns
$t_v(MISO)$	MISO valid time			30	ns



### 3.4.3 Operating Modes

MFC-1082 offers a variety of modes that can be optimized for different degrees of performance, including Image Capture、Finger WakeUp。Host can control the MFC-1082 to enter different modes by means of the SPI instruction. In addition, MFC-1082 will be in the appropriate time to automatically switch mode. Mode switching concept diagram is as follows, you can further understand the function of the mode cut.

### 3.4.4 Image Capture Modes

Image Capture Mode is the main function of MFC-1082, used to obtain fingerprints and transmission of data. This mode is to maintain the highest performance to capture fingerprint sensing data, with other modes of control, optimize the overall system power consumption.

### 3.4.5 Finger Wakeup Mode

MFC-1082 design while turn-off screen, enter the Finger WakeUp Mode, to maintain a low spend and low power consumption, does not require any Host resources. When the finger down and keep stable, MFC-1082 INT will notify Host, if identified as correct finger, the phone will wake up. If not correct finger, MFC-1082 will re-enter the power saving mode.



## 4 Package Information

### 4.1 Package Information

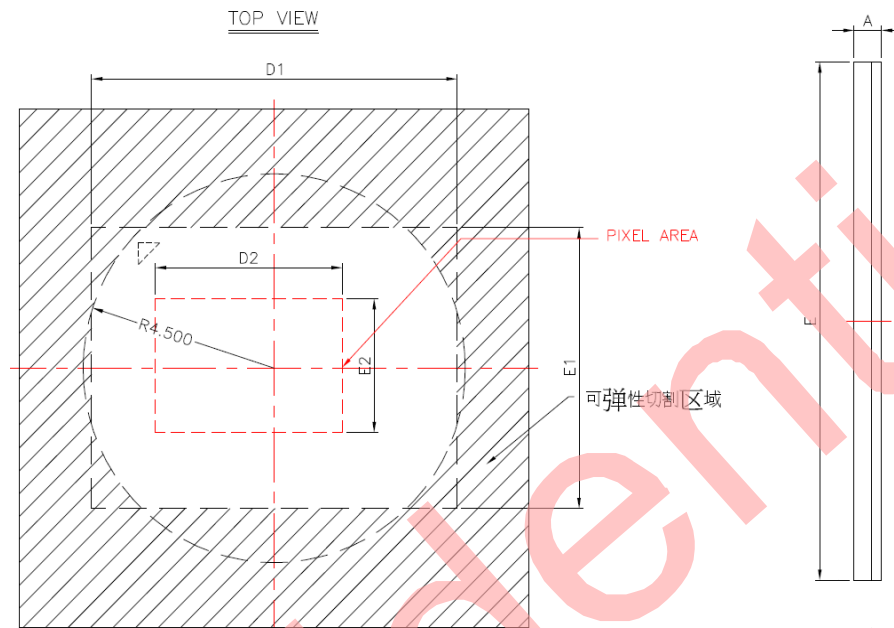

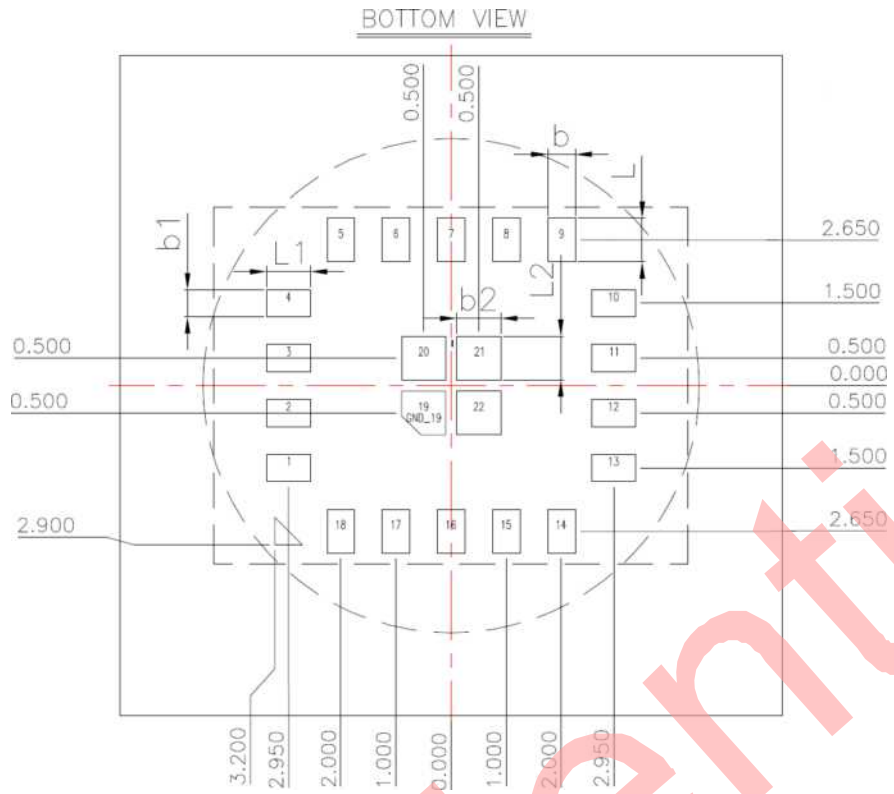

SYMBOL	DIMENSION(mm)			REMARK
	MIN.	NOM.	MAX.	
A	0.6	0.65	0.7	
D	11.9	12	12.1	
D1	8.55	8.6	8.65	
D2	--	4.4	--	
E	11.9	12	12.1	
E1	6.45	6.5	6.55	
E2	--	3.1	--	
b	0.45	0.5	0.55	
b1	0.45	0.5	0.55	
b2	0.75	0.8	0.85	
L	0.75	0.8	0.85	
L1	0.75	0.8	0.85	
L2	0.75	0.8	0.85	



### 5 Revision history

Version	Date	Changes	Approved	Checked	Author
V0.1	2020/08/14	Initial draft	Mark	John	Eric Lee

Confidential