

WSK-900-0024



Hand Wash Mon. Kit, Universal, Ethernet Interface



General Description

This kit contains a complete solution for monitoring one handwashing station. It features the Smart.Hub (Pro, Ethernet version) with power supply and antennas for cloud connectivity and (1) hand-soap sensor. If this kit is designated as "Universal" then the sensor device will be a unit that installs next to a soap dispenser to pick up when hands enter and leave the soap well area. If this kit is designated as "Smart" then the kit includes a hand-soap dispenser with a Whisker.io™ device installed in the dispenser to count uses.

This bundle contains the following components:

Quantity	Part Number	Description	
1	WH1-9-00-PDNEN-N	Smart.Hub™ Pro, Ethernet Interface Whisker.io™, Smart.Hub™, Pro, 900MHz, Ethernet, 120VAC	
1	SS1-1-900-U	Universal Soap Dispenser Sensor Universal Soap Dispenser Sensor, 900MHz, battery powered, int. antenna	



WH1-9-00-PDNE-N

Smart.Hub™ Pro, Ethernet Interface

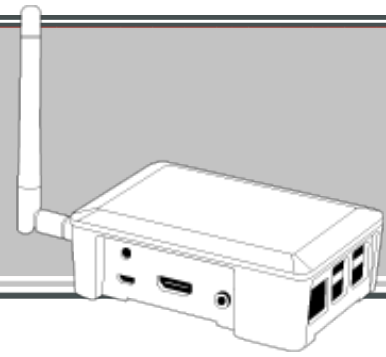

General Description

The Smart.Hub™ Pro is a versatile and reliable IOT gateway device for use in indoor applications. Smart.Hub™ products are gateways used to move data from Whisker.Block® sensor blocks and end user customized Whisker.Engine™ based sensor nodes to the Whisker.io™ cloud platform.

Features

- Plug and play operation
- Ethernet & Cellular options
- Data buffering during loss of connectivity
- Supports all Whisker.io Cloud services
- Works with 3rd party platforms via Whisker.io Forwarding
- Supports two-way communication with field devices – monitor and control
- Communicate with field devices over distances more than 1.6 kilometers.

Robustness and Reliability

If the hub loses connectivity to the Internet, it will buffer all incoming messages from field devices to storage on the SD card. When hub connectivity is restored, the messages will be sent to the cloud for storage and forwarding. In the event of catastrophic failure, the data on the SD card can be recovered using our Data Recovery App (Windows).

Throughput

The number of devices that can be supported by this hub varies with the reporting rate of the connected devices. This is a single channel hub, which ultimately determines its limitations; with a single channel, this hub can process about 1,800 messages an hour. The following table estimates device capacity for several different update rates.

Update Rate	Estimated number of devices
5 Minutes	250
1 Hour	1500
4 Hours	5000
24 Hours	10000

This hub supports two-way communications with field devices that support the Whisker.io™ protocol. For battery powered devices, the hub will queue down-stream messages (commands) and send them to the device when it reports in at its sampling interval; therefore, the command latency is equivalent to the update rate of the device. For line powered devices, commands are sent immediately, with a latency of less than 1 second.

Whisker.io Services

Storage



Devices that are configured with the storage service will persist their historic data in the Whisker.io cloud, making it available for visualization and analysis using our Whisker.io™ Portal web-based software.

Alerting



Rules based alerting allows a text or email to be sent when the specified condition is met and when it clears.

Dashboard



Secure, user friendly dashboard with visualization through gauges, graphs, sensor signal strength and fuel gauges.

Forwarding



The forwarding service allows two-way communications between Whisker.io devices and third party platforms such as Amazon, ThingLogix, etc.



Mechanical

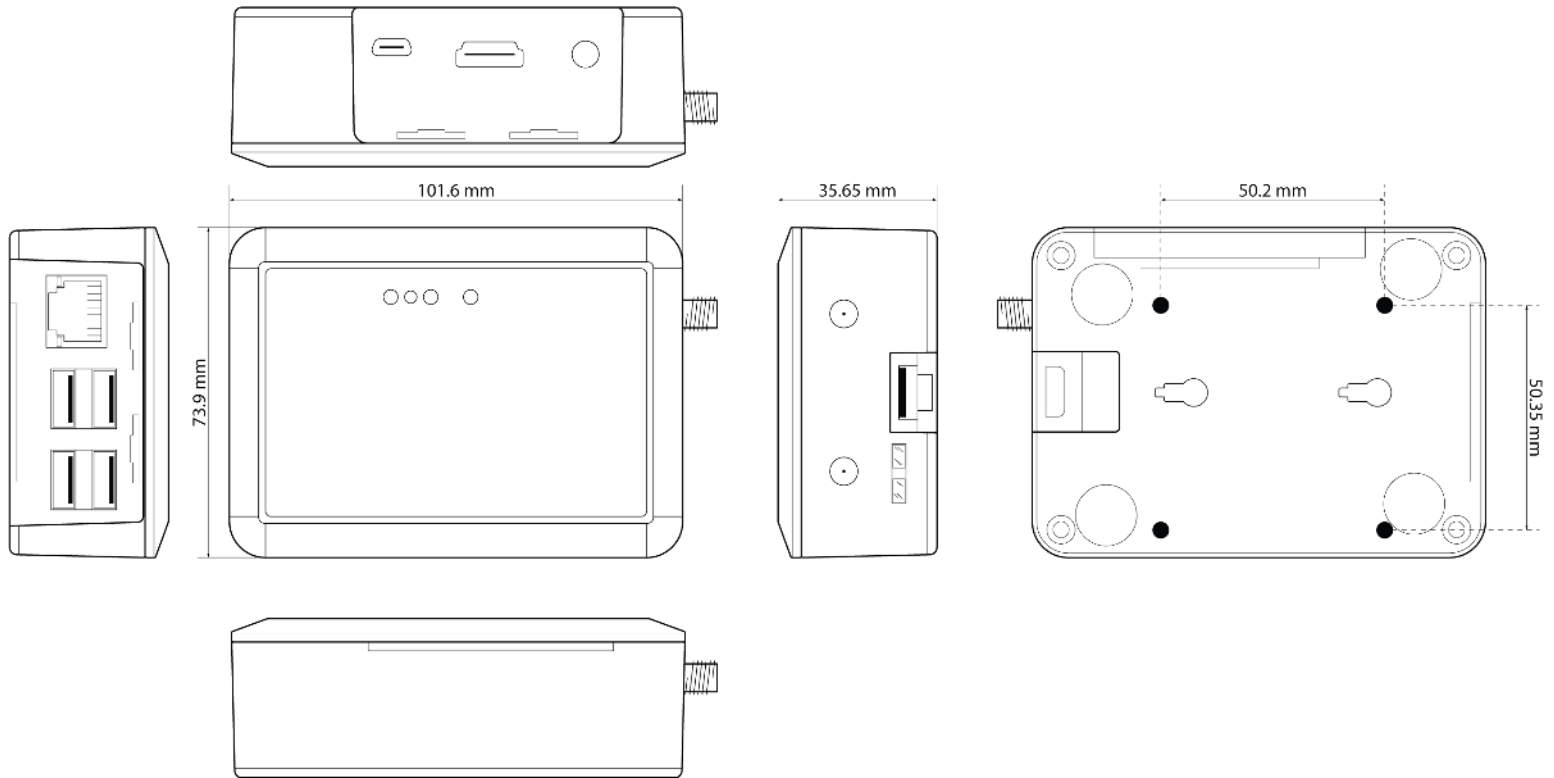

Connectivity Options

Every Whisker.io™ Hub can connect to the Internet via Ethernet. Hubs that are purchased with the Cellular option can also connect via Cellular.

Installation and Setup

All Whisker.io™ hubs are truly plug-and-play, requiring no provisioning or setup in the field. Simply mount the hub, connect it to power, and wait for all the status lights to come on.

Once a hub is installed, it is automatically configured to work with devices within its transmission range.

Order Information

Part Number	Description
WH1-9-00-PDNEN-N	Whisker.io™, Smart.Hub™, Pro, 900MHz, Ethernet, 120VAC



Whisker.io™

SS1-1-900-U

Universal Soap Dispenser Sensor

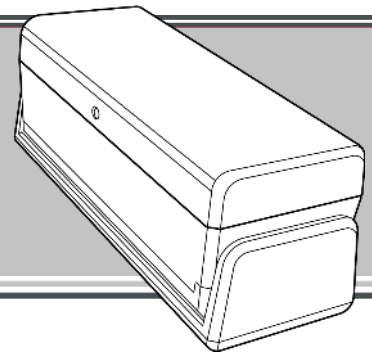

General Description

The Universal Soap Dispenser Sensor is an IOT enabled device that is mounted adjacent to any hand soap dispenser and counts the number of times soap is dispensed by sensing the presence of hands moving to and away from the soap dispenser.

The dispenser communicates to the cloud platform through our SmartHub family of cloud connected IOT hubs. It periodically communicates a message to the SmartHub indicating the battery voltage and the count of dispenses since it first began operation. This information can be used as a means of determining how much product has been dispensed since the last refill or to determine use frequency and time of day patterns to ensure hand wash policy compliance.

The long range, exceptional battery life and reliability make it the perfect choice for organizations looking for insight into the hygiene practices.

Power

The Universal Soap Dispenser is powered internally using a 3.7V, 5.2A-H LiThCl battery pack that should give 10+ years of service life before a battery change is required, assuming a 5 minute average dispense period.

Electrical Specifications

Parameter	Minimum	Typical	Maximum	Units
Battery Life—Standard Pack		10	20	Years
Operating Temp. Range	-4°C		+85°C	Degrees Celsius
Transmission Range		0.8 – 1.6		kilometers ¹
Frequency Range	902		928	MHz
Sensor Sample Rate		5		Minutes

1) Outdoors, line of sight, unobstructed, antenna elevation 10 feet

Order Information

Part Number	Description
SS1-1-900-U	Universal Soap Dispenser Sensor , 900MHz, battery powered, int. antenna

Internal Channels

This device is configured with two (2) internal channels:



Battery Voltage



Dispenser Count

Mounting

The Universal Soap Dispenser is mounted next to the device such that the infra-red sensor is pointed toward the area where a hand would be placed to acquire soap. The device should be mounted between 3 to 15 centimeters from the soap dispensing area. Note: the Universal Hand Dispenser must be mounted within range of a Smart.Hub for it's reading to be passed through the Cloud platform, and viewed in the Whisker Web Portal.

