

REVISIONS				
P	LTR	DESCRIPTION	DATE	APVD
	H2	REVISED AS PER ECO-20-003569.	11MAR2020	TC NP

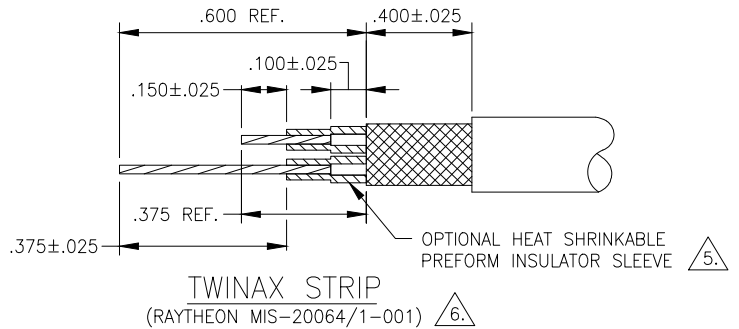
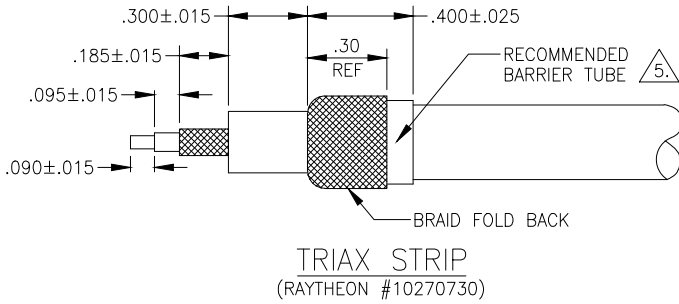
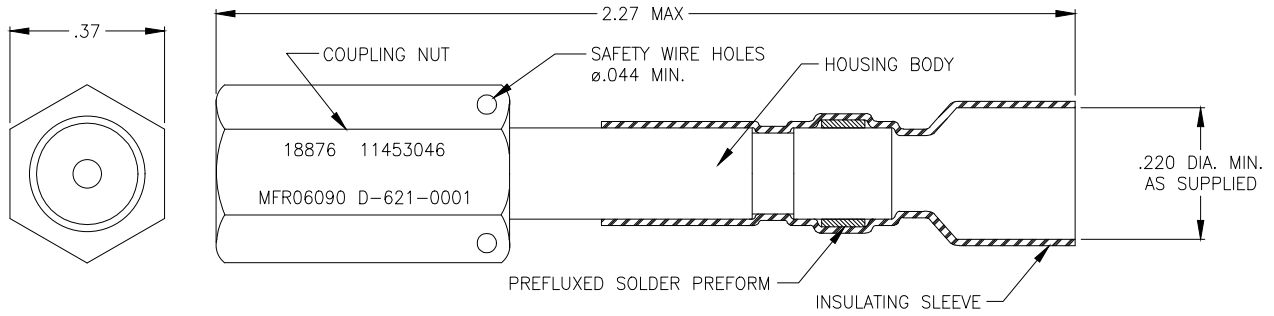

NOTES:

1. PART DESCRIPTION: CONNECTOR, PLUG SUBMINIATURE, TRIAXIAL (RAYTHEON # 114453046) COMPLETE WITH PREFLUXED SOLDER PREFORM RING AND HEAT SHRINKABLE SLEEVE.

MATERIAL:

- HOUSING BODY: BRASS ALLOY PER ASTM B16 (QQ-B-626)
- COUPLING NUT: STAINLESS STEEL, TYPE 303 PER ASTM A582.
- INSULATING SLEEVE: HEAT SHRINKABLE, POLYVINYLIDENE FLUORIDE (TRANSPARENT BLUE)
- SOLDER RING: PREFLUXED SOLDER PREFORM, COMPOSITION Sn63, ROLO FLUX PER ANSI-J-STD-004.
- INSULATOR: THERMOPLASTIC PER LP 392.

FINISH:

- HOUSING BODY: TIN PLATED PER MIL-T-10727
- COUPLING NUT: PASSIVATED PER QQ-P-35B.

- 2. HOUSING ACCOMMODATION: HOUSING DESIGNED TO ACCEPT SHIELDED CONTACTS MIS-20067/1 THRU MIS-20067/4 SHIELDED, RAYCHEM SOLDERTACT D-602-44/45 AND D-602-54/55.
- 3. WIRE SIZE: HOUSING WILL TERMINATE OUTER SHIELD OF TRIAX/TWINAX CABLE HAVING A SHIELD DIA. OF .185 MAX.
- 4. MATING CONNECTORS: THIS CONNECTOR WILL MATE WITH D-621-0002 (RAYTHEON# 11453047) AND D-621-0003 (RAYTHEON# 11453048) CONNECTOR, JACK, TRIAXIAL, BULKHEAD.

- 5. ITEMS SUPPLIED AS PART OF CONNECTOR ASSEMBLY.
- 6. RECOMMENDED TWINAX STRIPPING TOOL AD-1479 OR AD-1496.
- 7. SEE PROCEDURE ES 61124 FOR TERMINATION INFORMATION.

ACCESSORIES	
CTA-0012	BARRIER TUBE
CTA-0013	PREFORM INSULATOR SLEEVES (2)
D-600-0024	STRAIN RELIEF

TE Connectivity. All Rights Reserved. 2020



DIMENSIONS: INCHES	DWN T.CORREIA 11MAR2020	MATERIAL	FINISH
	CHK R.MACNAUGHTON 11MAR2020		
TOLERANCES UNLESS OTHERWISE SPECIFIED:	APVD N.PRZYBYLSKA 11MAR2020	TE Connectivity CONNECTOR, PLUG SUBMINIATURE, TRIAXIAL	
	PRODUCT SPEC		
0 PLC ± -		NAME	
1 PLC ± -		SIZE	
2 PLC ± 0.01		CAGE CODE	
3 PLC ± 0.005		DRAWING NO	
4 PLC ± -		RESTRICTED TO	
ANGLES ± -		WEIGHT	
		A4 06090 C-D-621-0001	
CUSTOMER DRAWING		SCALE	SHEET 1 OF 1 REV H2