

THIS DRAWING IS UNPUBLISHED. RELEASED FOR PUBLICATION
 © COPYRIGHT 2018 By - TE CONNECTIVITY ALL RIGHTS RESERVED.

REVISIONS					
P	LTR	DESCRIPTION	DATE	DWN	APVD
	A1	RELEASED PER ECR-20-009164	16JUL2020	MK	DH

- CONTINUOUS STRIP ON REELS
- ACCEPTS SINGLE WIRE RANGE 22-16 AWG
- INSULATION RANGE IS .070 - .130
- MATING TAB THK IS .033-.030
- RELEASED FOR PRODUCTION. FASR APPROVED UL LISTING PENDING

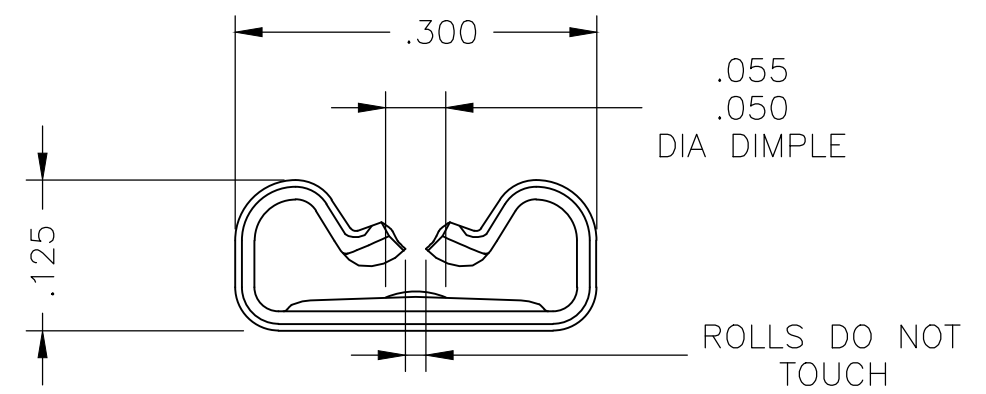
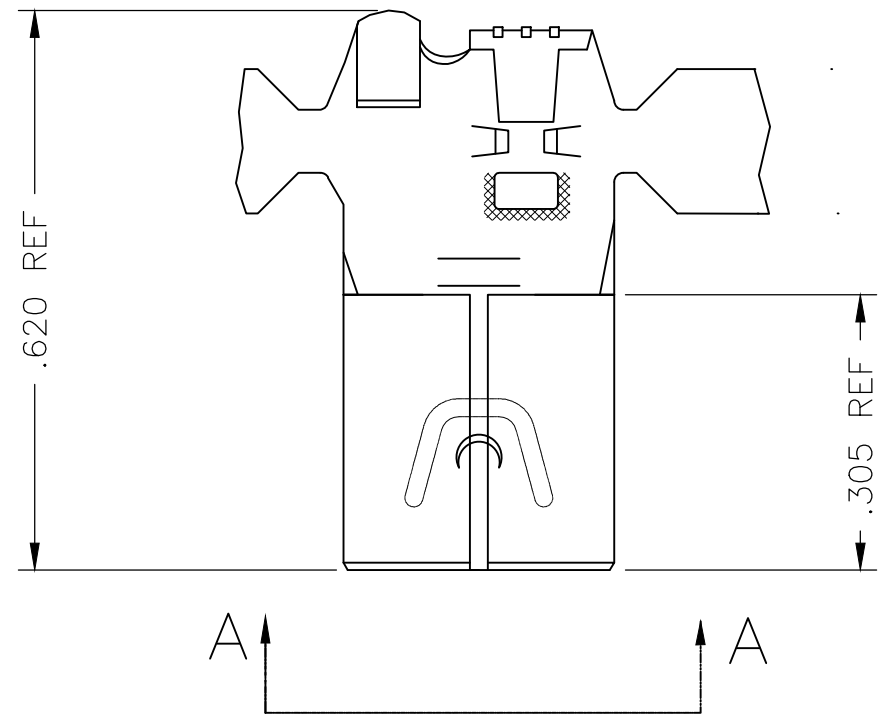

VIEW A-A
SCALE 8:1

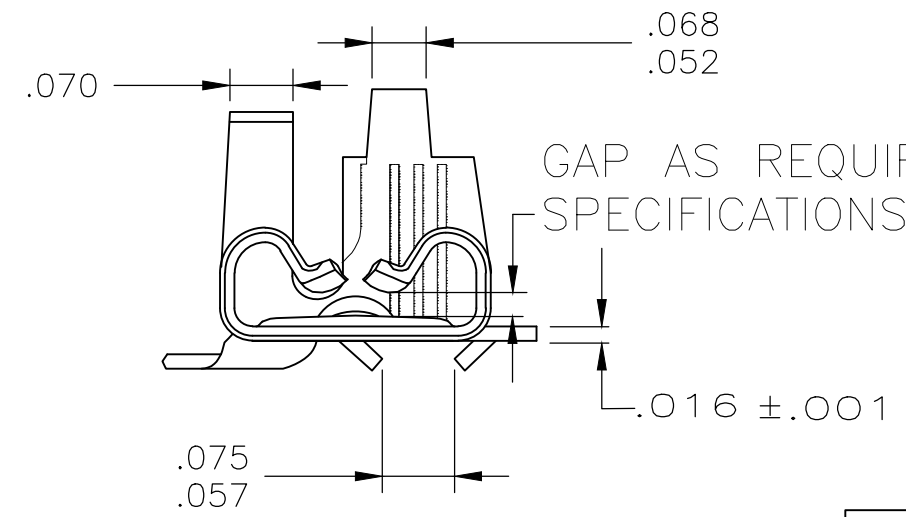

.070-.130	22-16 AWG	.033-.030	2238205-3
INSULATION RANGE	WIRE RANGE	TAB THK	PART NO

THIS DRAWING IS A CONTROLLED DOCUMENT.		DWN 16AUG2018 BASVESH WARAD	STE TE Connectivity Ltd.														
DIMENSIONS: INCHES		CHK 16AUG2018 HUMPHREY, DAVID				FASTON, .250 STD. REC., RH FLAG TAB, 22-16 AWG, TPBR											
TOLERANCES UNLESS OTHERWISE SPECIFIED:		APVD 16AUG2018 HUMPHREY, DAVID	NAME	SIZE	CAGE CODE												
<table border="1"> <tr><td>0 PLC</td><td>± -</td></tr> <tr><td>1 PLC</td><td>± -</td></tr> <tr><td>2 PLC</td><td>± .010</td></tr> <tr><td>3 PLC</td><td>± .010</td></tr> <tr><td>4 PLC</td><td>± -</td></tr> <tr><td>ANGLES</td><td>± 5</td></tr> </table>		0 PLC	± -	1 PLC	± -	2 PLC	± .010	3 PLC	± .010	4 PLC	± -	ANGLES	± 5	PRODUCT SPEC	DRAWING NO		RESTRICTED TO
0 PLC	± -																
1 PLC	± -																
2 PLC	± .010																
3 PLC	± .010																
4 PLC	± -																
ANGLES	± 5																
MATERIAL: BRASS		APPLICATION SPEC	114-2078														
FINISH: TIN		WEIGHT	0.000000														
CUSTOMER DRAWING			A3	00779	C-2238205												
			SCALE	5:1	SHEET 1 OF 1												
					REV A1												