

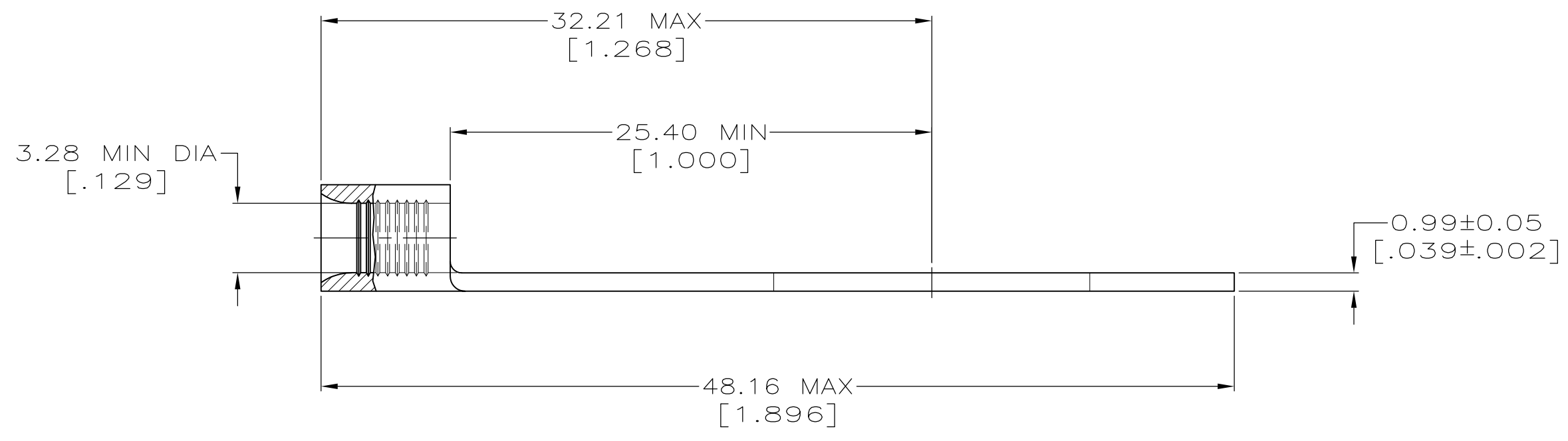

AMP WIRE RANGE	E13288 Listed
12-10 AWG SOLID OR STRANDED	12-10 AWG STRANDED
LR7189 Certified	MILITARY P/N AND CLASS
12-10 AWG SOLID OR STRANDED	NOT APPLICABLE

STAMP AMP 12-10* APPROX AS SHOWN

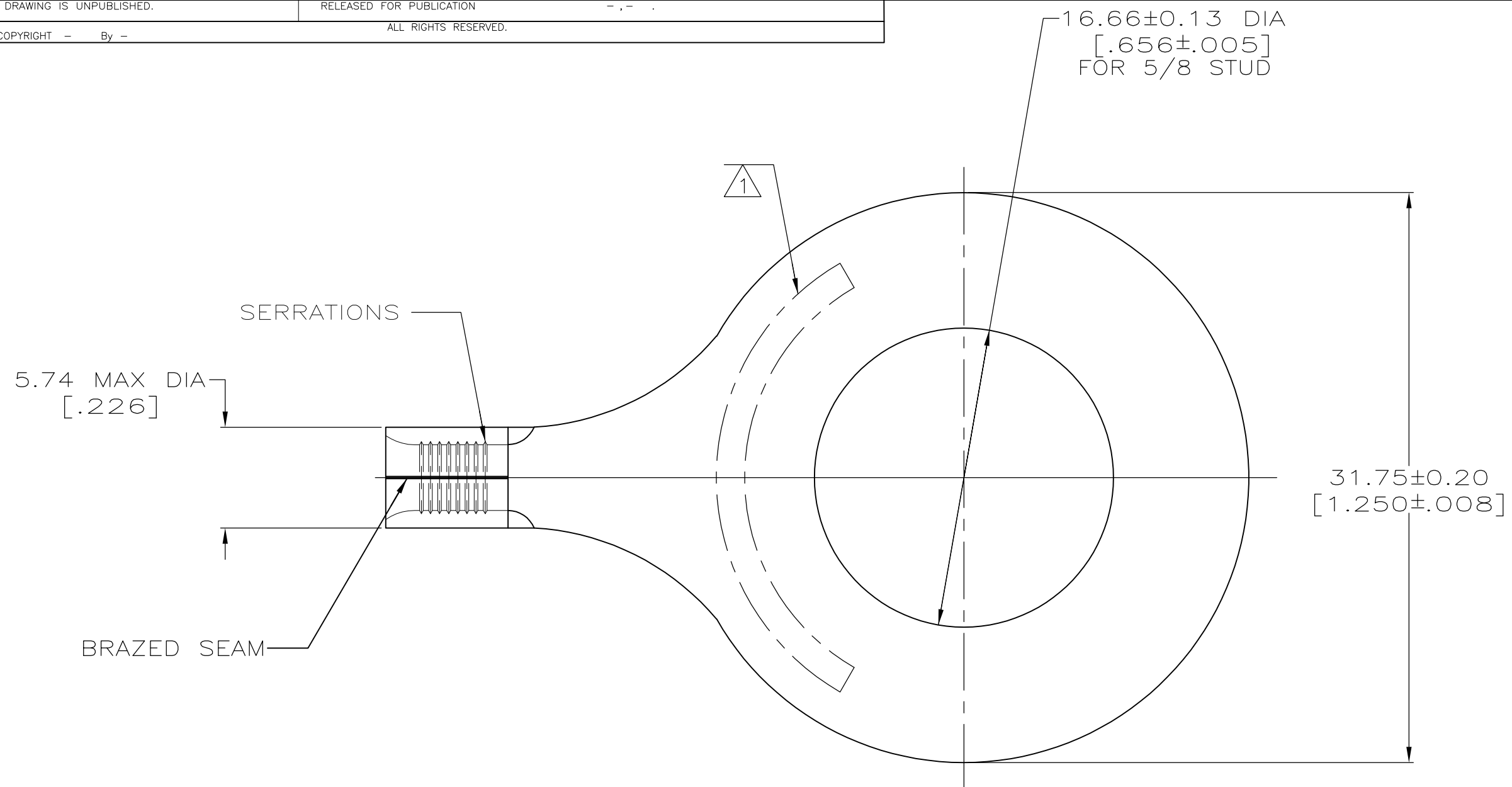

AMP INCORPORATED CUSTOMER SERVICE SYSTEMS		MAX RECOMMENDED OPERATING TEMPERATURE: 170° C MAX
FOR ADDITIONAL PRODUCT INFORMATION OR COPIES OF DRAWINGS AND TECHNICAL DOCUMENTS	PRODUCT INFORMATION CENTER 1-800-522-6752	VOLTAGE RATING: NOT APPLICABLE
FOR APPLICATION TOOLING INFORMATION	TOOLING ASSISTANCE CENTER 1-800-722-1111	WIRE CROSS SECTIONAL AREA RANGE: 2.62-6.64mm ² [5,180-13,100] CIR MILS SOLID OR STRANDED
FOR ORDER ENTRY	1-800-526-5142	

THIS DRAWING IS A CONTROLLED DOCUMENT.		DWN TA BRINKMAN 3-17-93	TE Connectivity	
DIMENSIONS: mm[INCHES]		CHK DA PATTERSON 3-17-93	NAME TERMINAL, RING TONGUE, SOLISTRAND™	
TOLERANCES UNLESS OTHERWISE SPECIFIED: 0 PLC ± - 1 PLC ± - 2 PLC ± - 3 PLC ± - 4 PLC ± - ANGLES ± ± -		APVD DE MILLER 3-17-93	PRODUCT SPEC APPLICATION SPEC	
MATERIAL COPPER PER ASTM B-152 ANNEALED	FINISH TIN PLATE 0.00254[.000100] MIN THK PER MIL-T-10727	WEIGHT -	SIZE A2	CAGE CODE 00779
CUSTOMER DRAWING		DRAWING NO G-320764	RESTRICTED TO -	SCALE 4:1
		SHEET 1 of 1	REV C1	