

AMMP-6333

18 – 33 GHz, 0.2 W Driver Amplifier in SMT Package



Data Sheet



Description

The AMMP-6333 is a broadband 0.2 W driver amplifier designed for use in transmitters operating in various frequency bands from 18 GHz to 33 GHz. This small, easy to use device provides over 23 dBm of output power (P_{-1dB}) and more than 20 dB of gain at 25 GHz. It was optimized for linear operation with an output power at the third order intercept point (OIP3) of 30dBm. The AMMP-6333 features a temperature compensated RF power detection circuit that enables power detection sensitivity of 0.3 V/W at 25GHz. It is fabricated using Avago Technologies unique 0.25 μ m E-mode PHEMT technology which eliminates the need for negative gate biasing voltage.

Package Diagram

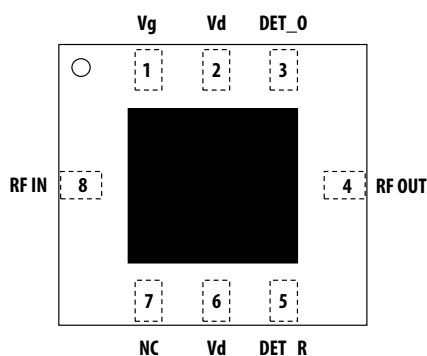

Features

- Frequency range: 18 to 33 GHz
- Small signal gain: 20 dB
- P-1dB : 23dBm
- Return Loss (In/Out): -10 dB

Applications

- Microwave Radio systems
- Satellite VSAT, Up/Down Link
- LMDS & Pt-Pt mmW Long Haul
- Broadband Wireless Access (including 802.16 and 802.20 WiMax)
- WLL and MMDS loops

Functional Block Diagram

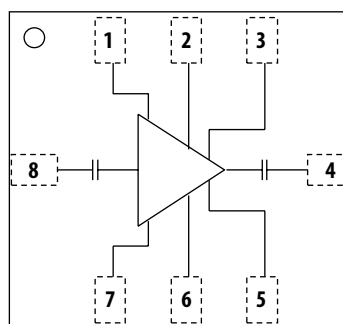

Pin	Function
1	Vg
2	Vd
3	DET_O
4	RF_out
5	DET_R
6	Vd
7	NC
8	RF_in



Attention: Observe precautions for handling electrostatic sensitive devices.

ESD Machine Model (Class A) = 90 V
ESD Human Body Model (Class 1A) = 300 V
Refer to Avago Application Note A004R:
Electrostatic Discharge, Damage and Control.

Note: MSL Rating = Level 2A

Electrical Specifications

1. Small/Large -signal data measured in a fully de-embedded test fixture form TA = 25°C.
2. Pre-assembly into package performance verified 100% on-wafer per AMMC-6220 published specifications.
3. This final package part performance is verified by a functional test correlated to actual performance at one or more frequencies.
4. Specifications are derived from measurements in a 50 Ω test environment. Aspects of the amplifier performance may be improved over a more narrow bandwidth by application of additional conjugate, linearity, or low noise (Γopt) matching.
5. All tested parameters guaranteed with measurement accuracy +/- 2dB for P1dB of 17,25 and 32GHz +/- 0.5 for Gain of 17GHz, +/- 1 dB for Gain of 25 and 32GHz

Table 1. RF Electrical Characteristics

TA=25°C, Vd=3.0V, Id(Q)=230mA, Zin=Zo=50 Ω

Parameter	17-20GHz			20-30GHz			30-33GHz			Unit	Comment
	Min	Typ	Max	Min	Typ	Max	Min	Typ	Max		
Small Signal Gain, Gain	14	16		19	22		18	20.5		dB	
Output Power at 1dB Gain Compression, P1dB	18	20.5		22	24.5		21	24		dBm	
Output Power at 3dB Gain Compression, P3dB		21.5			24.5			23.5		dBm	
Output Third Order Intercept Point, OIP3		30			30			30		dBm	
Reverse Isolation, Iso		45			45			45		dB	
Input Return Loss, Rlin		10			10			8		dB	
Output Return Loss, RLout		10			14			10		dB	

Table 2. Recommended Operating Range

1. Ambient operational temperature TA = 25°C unless otherwise noted.
2. Channel-to-backside Thermal Resistance (Tchannel (Tc) = 34°C) as measured using infrared microscopy. Thermal Resistance at backside temperature (Tb) = 25°C calculated from measured data.

Description	Min.	Typical	Max.	Unit	Comments
Drain Supply Current, Id		230		mA	Vd=5 V, Vg set for typical IdQ – quiescent current
Gate Supply Operating Voltage, Vg		2		V	IdQ = 230 mA
Gate Supply Current, Ig		7		mA	

Table 3. Thermal Properties

Parameter	Test Conditions	Value
Maximum Power Dissipation	Tbaseplate = 85°C	PD = 2.5W Tchannel = 150°C
Thermal Resistance, θ_{jc}	Vd = 5V Id = 230mA PD = 1.15W Tbaseplate = 85°C	θ_{jc} = 27 °C/W Tchannel = 116°C
Thermal Resistance, θ_{jc} Under RF Drive	Vd = 5V Id = 400mA Pout = 24dBm PD = 2W Tbaseplate = 85°C	θ_{jc} = 27 °C/W Tchannel = 139°C

Absolute Minimum and Maximum Ratings**Table 4. Minimum and Maximum Ratings**

Description	Min.	Max.	Unit	Comments
Drain to Gate Voltage, Vd-Vg		14	V	
Positive Supply Voltage, Vd		5.5	V	
Gate Supply Voltage, Vg		0 to 2.5	V	
Power Dissipation, PD		2.5	W	
CW Input Power, Pin		20	dBm	
Channel Temperature, Tch		+150	°C	
Storage Temperature, Tstg	-65	+155	°C	
Maximum Assembly Temperature, Tmax		320	°C	30 second maximum

Notes:

1. Operation in excess of any one of these conditions may result in permanent damage to this device.

Typical Performance

($T_A = 25^\circ\text{C}$, $V_d = 5\text{ V}$, $I_{dQ} = 230\text{ mA}$, $Z_{in} = Z_{out} = 50\ \Omega$)

(Data obtained from a test fixture with 2.4 mm connectors. Effects of the test fixture – losses and mismatch – have not been removed from the data)

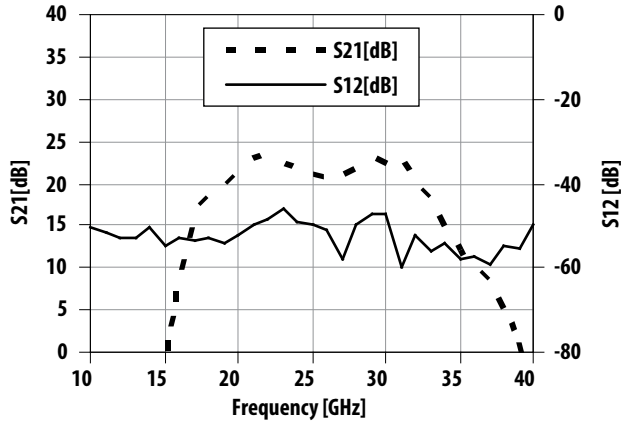

Figure 1. Gain and Reverse Isolation vs Frequency

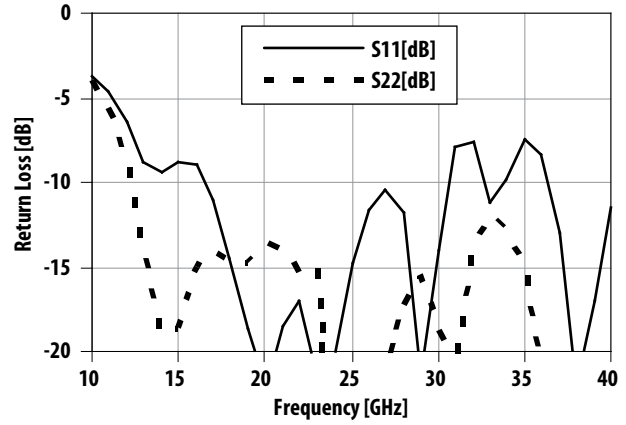

Figure 2. Return Loss vs Frequency

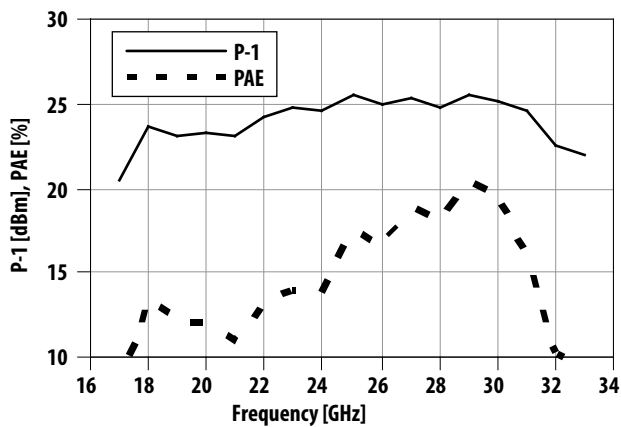

Figure 3. P-1dB and PAE vs Frequency

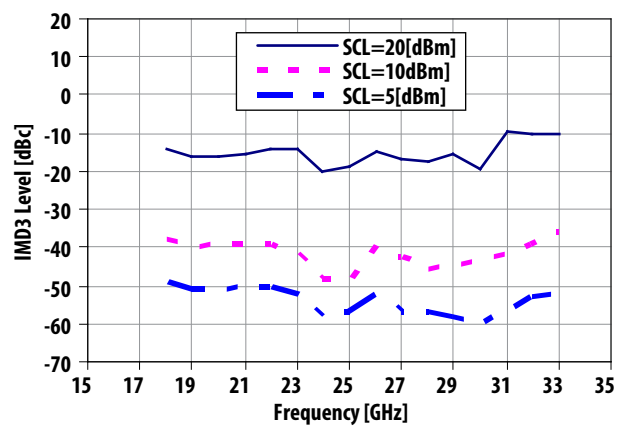

Figure 4. Typical IMD3 vs Frequency (SCL = Single Carrier level)

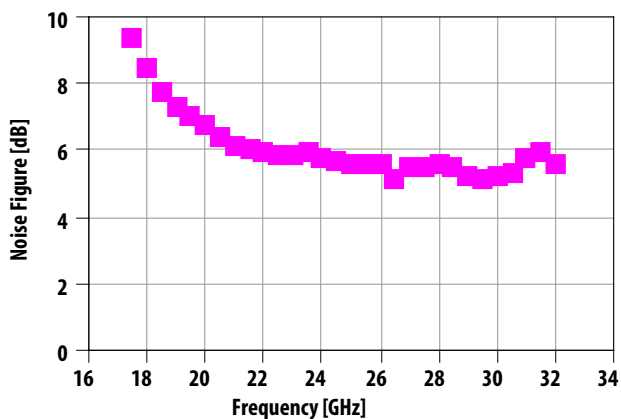

Figure 5. Typical Noise Figure vs Frequency

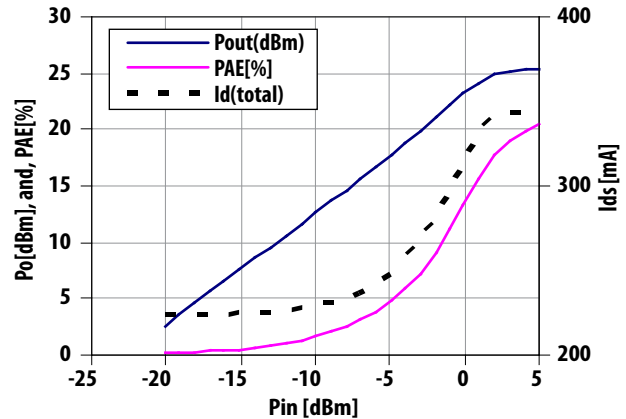

Figure 6. Output Power, PAE, and Drain Current vs Input Power at 30GHz

Typical Performance (continued)

($T_A = 25^\circ\text{C}$, $Z_{in} = Z_{out} = 50 \Omega$)

(Data obtained from a test fixture with 2.4 mm connectors. Effects of the test fixture – losses and mismatch – have not been removed from the data)

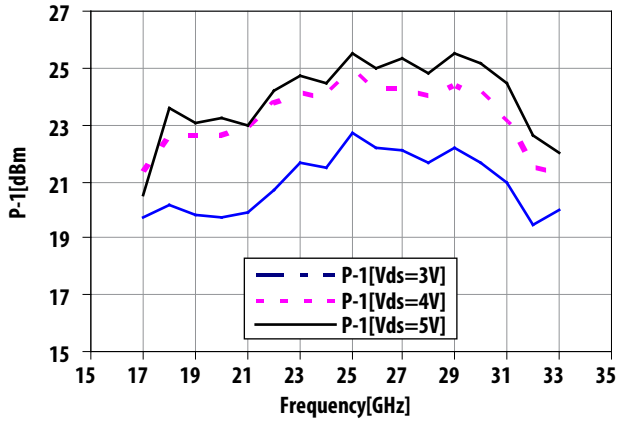

Figure 7. P-1dB vs Frequency and Vds, ($I_{dQ}=230\text{mA}$)

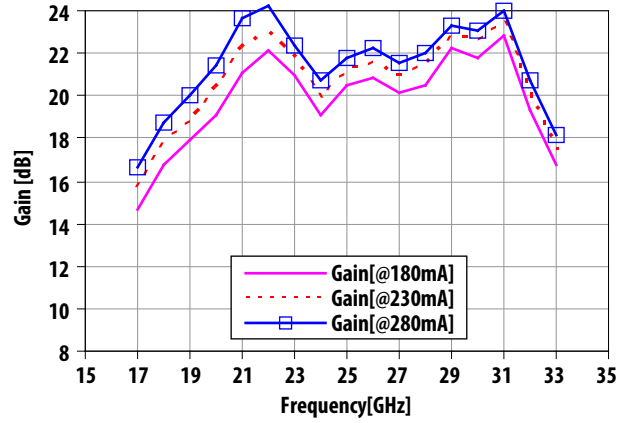

Figure 8. Small signal gain vs Frequency and I_{dQ} , ($V_{ds}=5\text{V}$)

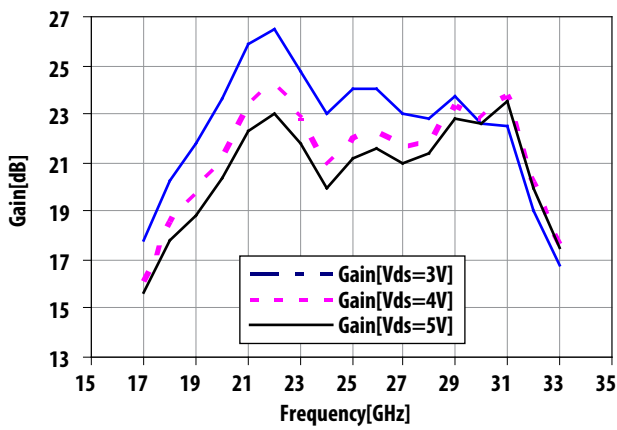

Figure 9. Small signal gain vs Frequency and Vds, ($I_{dQ}=230\text{mA}$)

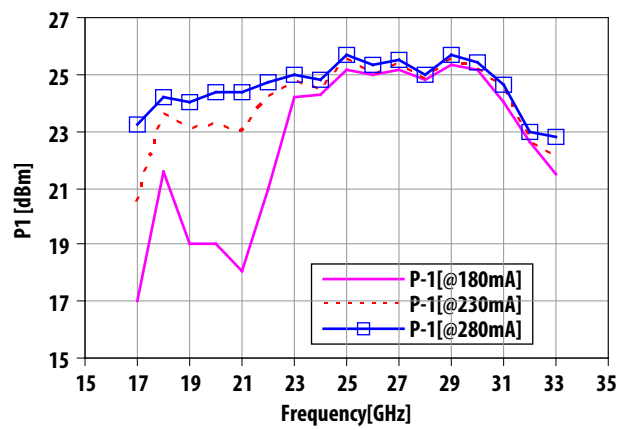

Figure 10. P-1dB vs Frequency and I_{dQ} , ($V_{ds}=5\text{V}$)

Typical Performance (continued)

($V_d = 5\text{ V}$, $I_{dQ} = 230\text{ mA}$, $Z_{in} = Z_{out} = 50\ \Omega$)

(Data obtained from a test fixture with 2.4 mm connectors. Effects of the test fixture – losses and mismatch – have not been removed from the data)

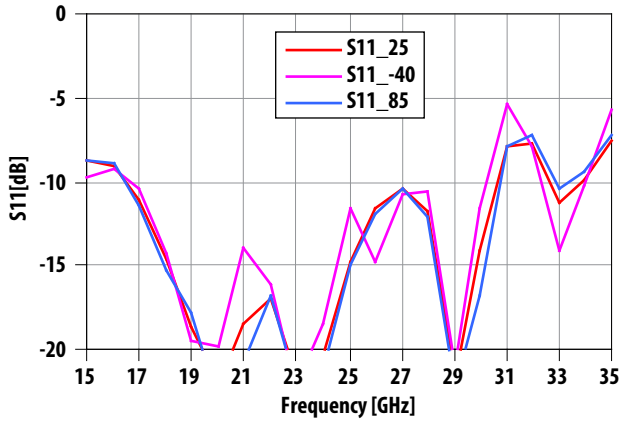

Figure 11. $|S_{11}|$ vs Frequency and Temperature

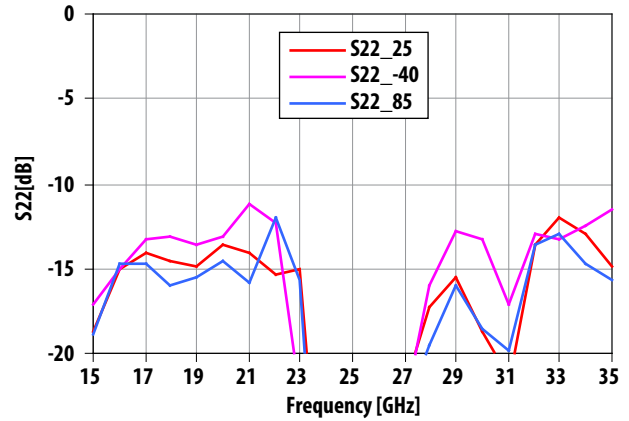

Figure 12. $|S_{22}|$ vs Frequency and Temperature

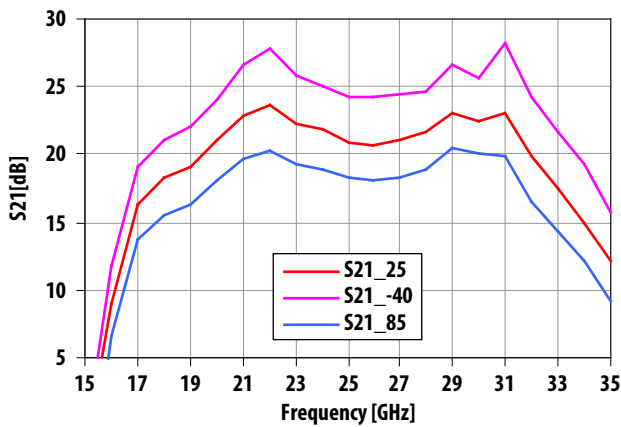

Figure 13. $|S_{21}|$ vs Frequency and Temperature

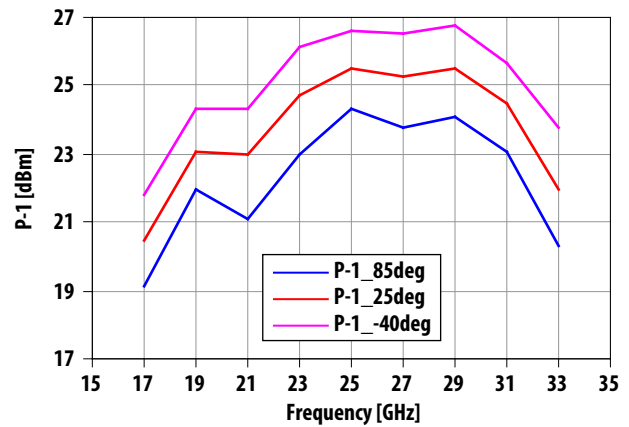

Figure 14. P_{-1dB} vs Frequency and Temperature

Biasing Considerations

The AMMP-6333 is a balanced amplifier consisting of two four stage single-ended amplifiers, two Lange couplers, a power monitoring detector, a reference detector for temperature compensation, and a current mirror for the gate biasing (Figure 15).

The recommended quiescent DC bias conditions for optimum gain, output power, efficiency, and reliability are: $V_d = 5\text{ V}$ with V_g set for $I_{dQ} = 230\text{ mA}$. The drain bias voltage range is from 3 to 5 V. Drain current range is from 200 mA to 350 mA. The AMMC-6333 can be biased with a dual or single positive DC source (Figure 16).

The output power detection network provides a way to monitor output power. The differential voltage between the DET_R and DET_O outputs can be correlated with the RF power emerging from the RF output port. This voltage is given by:

$$V = (V_{\text{DET_R}} - V_{\text{DET_O}}) - V_{\text{OFS}}$$

Where:

$V_{\text{DET_R}}$ is the voltage at the DET_R port

$V_{\text{DET_O}}$ is a voltage at the DET_O port

V_{OFS} is the offset voltage at zero input power

The offset voltage (V_{OFS}) can be at each power level by turning off the input power and measuring V . The error due to temperature drift should be less than 0.01dB/50°C. When V_{OFS} is determined at a single reference temperature the drift error should be less than 0.25dB. Finally, V_{OFS} be characterized over a range of temperatures and stored in a lookup table, or it can be measured at two temperatures and a linear fit used to calculate V_{OFS} at any temperature.

The RF ports are AC coupled at the RF input to the first stage and the RF output of the final stage. No ground wires are needed since ground connections are made with plated through-holes to the backside of the device.

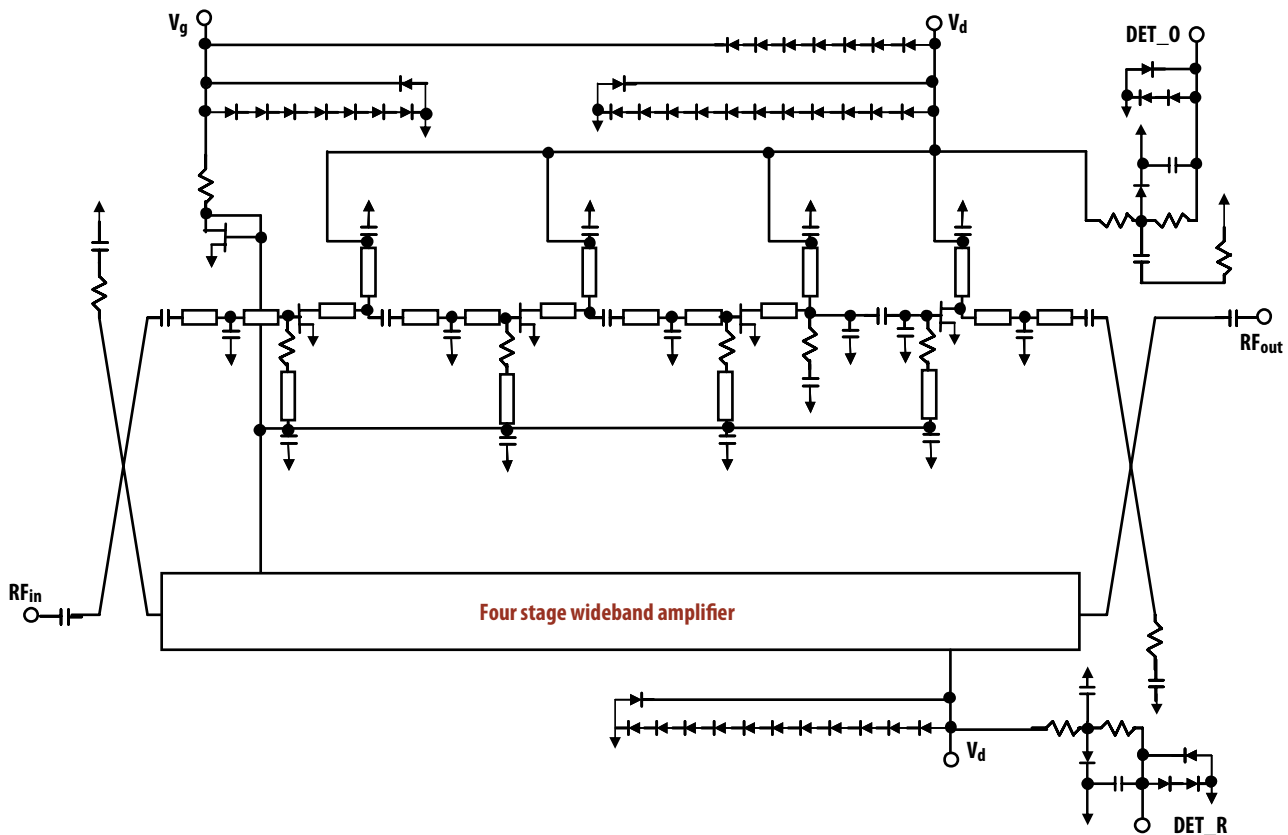
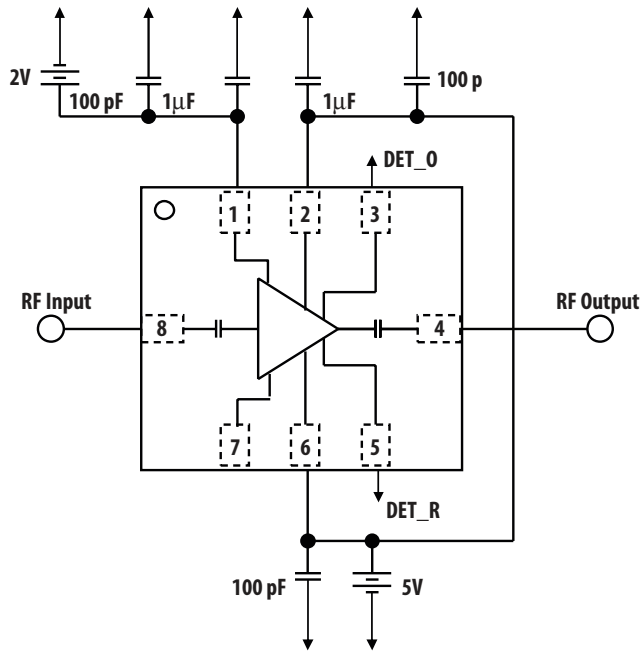
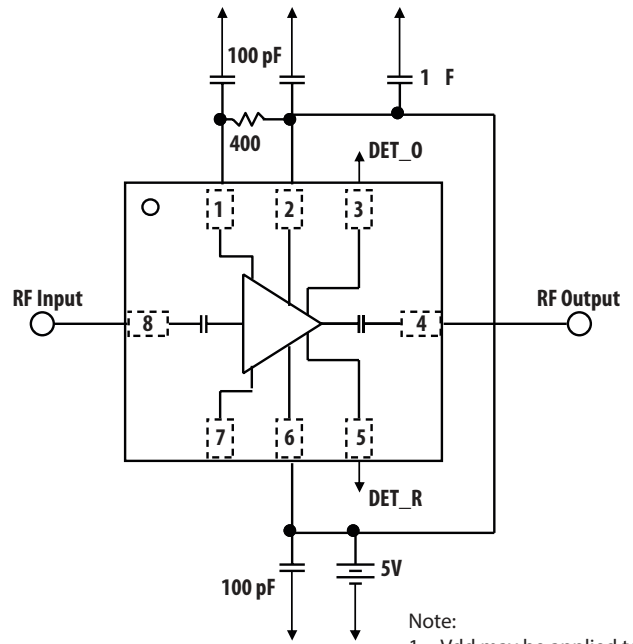

Figure 15. AMMC-6333 schematic

1. Dual positive DC power supply



2. Single positive DC power supply



Note:
1. Vdd may be applied to either Pin 2 or Pin 6.

Figure 16. AMMP-6333 assembly examples, Vd pins must be biased from both sides

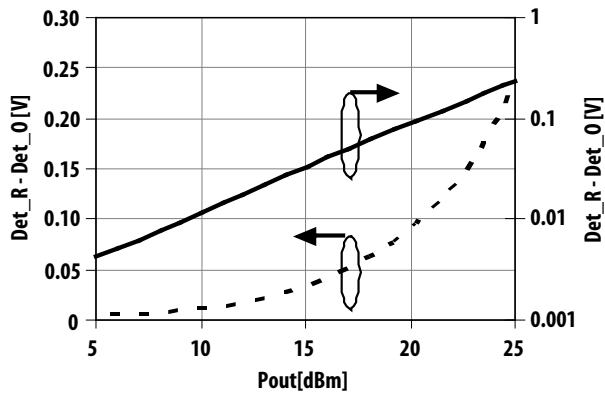

Figure 17. AMMP-6333 Typical Detector Voltage and Output Power, Freq=30GHz

Typical Scattering Parameters

Please refer to <<http://www.avagotech.com>> for typical scattering parameters data.

Package Dimension, PCB Layout and Tape and Reel information

Please refer to Avago Technologies Application Note 5520, AMxP-xxxx production Assembly Process (Land Pattern A).

Ordering Information

Part Number	Devices Per Container	Container
AMMP-6333-BLKG	10	Antistatic bag
AMMP-6333-TR1G	100	7" Reel
AMMP-6333-TR2G	500	7" Reel

For product information and a complete list of distributors, please go to our web site: www.avagotech.com

Avago, Avago Technologies, and the A logo are trademarks of Avago Technologies in the United States and other countries. Data subject to change. Copyright © 2005-2013 Avago Technologies. All rights reserved.
AV02-1447EN - July 9, 2013

