

# SPECIFICATION CONTROL DRAWING

THIS DRAWING CONTAINS INFORMATION PROPRIETARY TO RF INDUSTRIES, LTD. ANY UNAUTHORIZED USE OF THIS DRAWING IS EXPRESSLY PROHIBITED. ANY VIOLATION IS PUNISHABLE UNDER U.S. COPYRIGHT LAWS.

REV	DESCRIPTION	DWN	DATE	APPROVED
E	DIELECTRIC NOW 2 PIECES [#4] & [#5], CHG MNTG CONFIG	CZS	3/16/98	R. RICE
F	ADD NOTE TO STRIP INSTR / ADD TOLERANCE TO TOL BLOCK	CZS	2/24/99	R. RICE
G	CHANGED FERRULE STUD TO KNURL CONFIGURATION	JDM	11/2/99	R. RICE
H	CHG ITEM #2 & #3 ID DIMENSIONS & SLOTS CALL OUT	CZS	3/22/00	J. D. McR.

ALL DIMENSIONS ARE REFERENCE ONLY

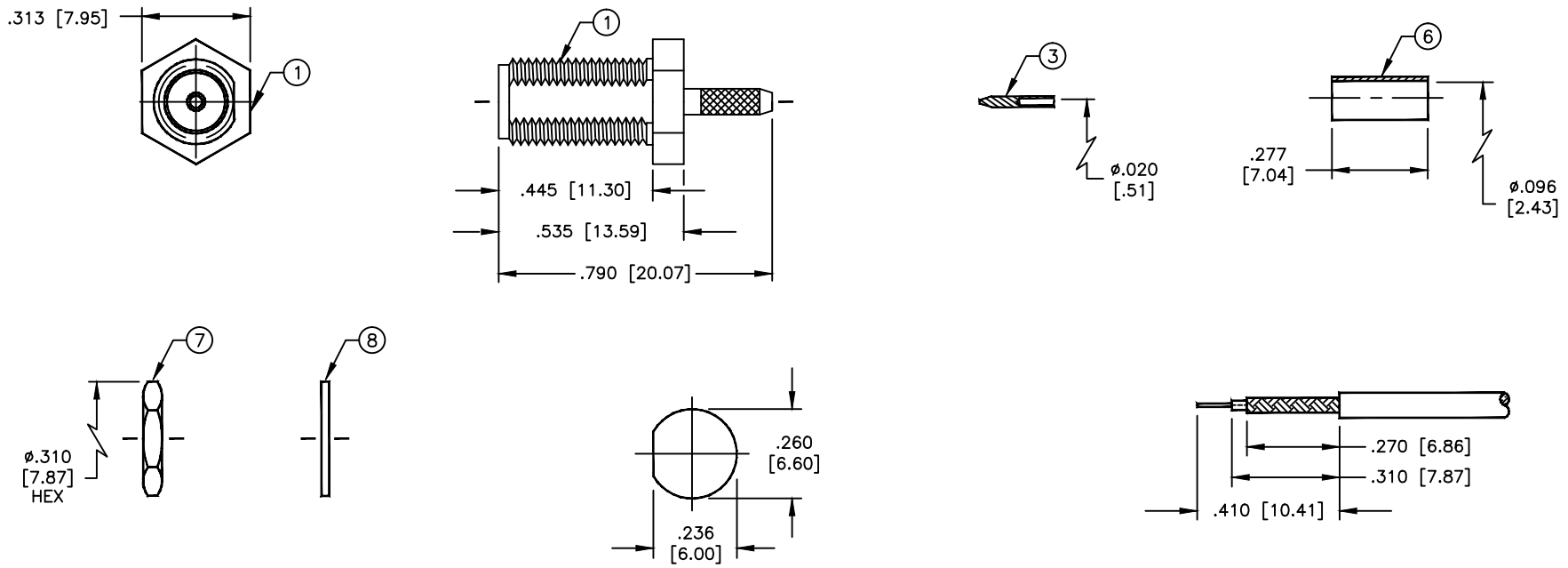

SUGGESTED MOUNTING CONFIGURATION

SUGGESTED STRIPPING INSTRUCTIONS  
 COMB BRAID BEFORE SLIDING FERRULE IN PLACE  
 RECOMMENDED CRIMP DIE: .100  
 PIN TO BE SOLDERED

## SPECIFICATIONS:

IMPEDANCE: 50 OHMS  
 WORKING VOLTAGE: 375V PEAK @ SEA LEVEL  
 FREQUENCY RANGE: 0-12.4 GHz  
 INSERTION LOSS:  $\leq$  -.2dB @ 6 GHz  
 VSWR MAX: 1.3:1 @ 12 GHz  
 FOR RG-178, 178A, 178B, 196 & 196A/U CABLE

DIMENSIONS ARE IN INCHES AND [MILLIMETERS]

UNLESS OTHERWISE NOTED TOLERANCES ARE:

DECIMALS DIAMETER

DRAWN C. ZUNIGA 3/22/00

CHECKED

ORJ DRAWN K. MAXWELL 4/29/96

APPROVALS DATE

**RFconnectors**  
 DIVISION OF RF INDUSTRIES, LTD.

7610 MIRAMAR RD  
 SAN DIEGO, CA 92126  
 (858) 549-6340  
 (858) 549-6345 FAX

RSA-3252-A-4

SMA FEMALE REVERSE GENDER BULKHEAD CRIMP

ITEM	DESCRIPTION	QTY	MATERIAL	FINISH
8	LOCK WASHER [LKW-250]	1	BRASS	NICKEL
7	HEX NUT [HEX-250-36S]	1	BRASS	NICKEL
6	FERRULE	1	BRASS	NICKEL
5	DIELECTRIC	1	PTFE	NONE
4	DIELECTRIC	1	PTFE	NONE
3	CONTACT	1	BRASS	GOLD
2	CONTACT	1	BRASS	GOLD
1	BODY	1	BRASS	NICKEL

SIZE	CABLE GROUP	DWG NO.	REV
A	A	8636	H
SCALE: 2:1		CAD FILE	SHEET 1 OF 1