



FOD3120

High Noise Immunity, 2.5A Output Current, Gate Drive Optocoupler

Features

- High noise immunity characterized by 35kV/μs minimum common mode rejection
- 2.5A peak output current driving capability for most 1200V/20A IGBT
- Use of P-channel MOSFETs at output stage enables output voltage swing close to the supply rail
- Wide supply voltage range from 15V to 30V
- Fast switching speed
 - 400ns max. propagation delay
 - 100ns max. pulse width distortion
- Under Voltage LockOut (UVLO) with hysteresis
- Extended industrial temperature range, -40°C to 100°C temperature range
- Safety and regulatory approved
 - UL1577, 5000 V_{RMS} for 1 min.
 - IEC60747-5-2
- R_{DS(ON)} of 1Ω (typ.) offers lower power dissipation
- >8.0mm clearance and creepage distance (option 'T' or 'TS')
- 1,414V Peak Working Insulation Voltage (V_{IORM})

Applications

- Industrial inverter
- Uninterruptible power supply
- Induction heating
- Isolated IGBT/Power MOSFET gate drive

Description

The FOD3120 is a 2.5A Output Current Gate Drive Optocoupler, capable of driving most 1200V/20A IGBT/MOSFET. It is ideally suited for fast switching driving of power IGBT and MOSFETs used in motor control inverter applications, and high performance power system.

It utilizes Fairchild's proprietary coplanar packaging technology, Optoplanar[®], and optimized IC design to achieve high noise immunity, characterized by high common mode rejection.

It consists of a gallium aluminum arsenide (AlGaAs) light emitting diode optically coupled to an integrated circuit with a high-speed driver for push-pull MOSFET output stage.

Related Resources

- FOD3150, 1A Output Current, Gate Drive Optocoupler Datasheet
- www.fairchildsemi.com/products/opto/

Functional Block Diagram

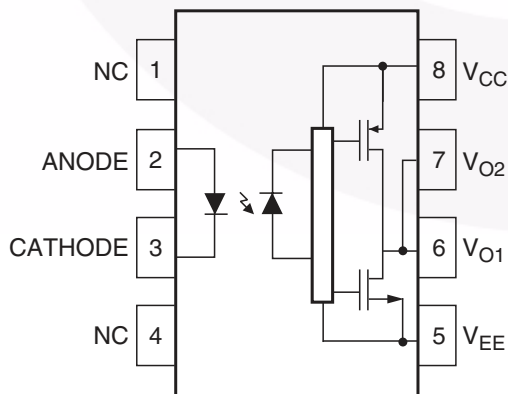

Note:

A 0.1μF bypass capacitor must be connected between pins 5 and 8.

Package Outlines

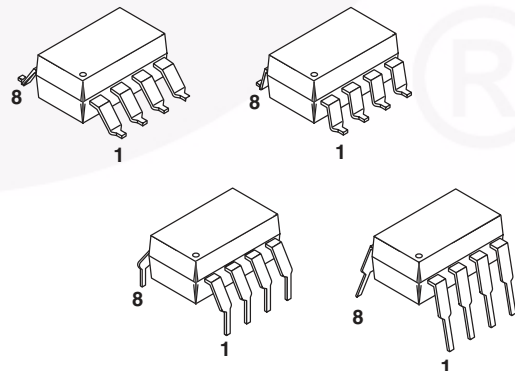

Truth Table

LED	$V_{CC}-V_{EE}$ “Positive Going” (Turn-on)	$V_{CC}-V_{EE}$ “Negative Going” (Turn-off)	V_O
Off	0V to 30V	0V to 30V	Low
On	0V to 11.5V	0V to 10V	Low
On	11.5V to 13.5V	10V to 12V	Transition
On	13.5V to 30V	12V to 30V	High

Pin Definitions

Pin #	Name	Description
1	NC	Not Connected
2	Anode	LED Anode
3	Cathode	LED Cathode
4	NC	Not Connected
5	V_{EE}	Negative Supply Voltage
6	V_{O2}	Output Voltage 2 (internally connected to V_{O1})
7	V_{O1}	Output Voltage 1
8	V_{CC}	Positive Supply Voltage

Safety and Insulation Ratings

As per IEC 60747-5-2. This optocoupler is suitable for “safe electrical insulation” only within the safety limit data. Compliance with the safety ratings shall be ensured by means of protective circuits.

Symbol	Parameter	Min.	Typ.	Max.	Unit
	Installation Classifications per DIN VDE 0110/1.89 Table 1				
	For Rated Mains Voltage < 150Vrms		I-IV		
	For Rated Mains Voltage < 300Vrms		I-IV		
	For Rated Mains Voltage < 450Vrms		I-III		
	For Rated Mains Voltage < 600Vrms		I-III		
	For Rated Mains Voltage < 1000Vrms (Option T, TS)		I-III		
	Climatic Classification		40/100/21		
	Pollution Degree (DIN VDE 0110/1.89)		2		
CTI	Comparative Tracking Index	175			
V _{PR}	Input to Output Test Voltage, Method b, V _{IORM} × 1.875 = V _{PR} , 100% Production Test with t _m = 1 sec., Partial Discharge < 5pC	2651			
	Input to Output Test Voltage, Method a, V _{IORM} × 1.5 = V _{PR} , Type and Sample Test with t _m = 60 sec., Partial Discharge < 5 pC	2121			
V _{IORM}	Max Working Insulation Voltage	1,414			V _{peak}
V _{IOTM}	Highest Allowable Over Voltage	6000			V _{peak}
	External Creepage	8			mm
	External Clearance	7.4			mm
	External Clearance (for Option T or TS - 0.4" Lead Spacing)	10.16			mm
	Insulation Thickness	0.5			mm
	Safety Limit Values – Maximum Values Allowed in the Event of a Failure				
T _{Case}	Case Temperature	150			°C
I _{S,INPUT}	Input Current	25			mA
P _{S,OUTPUT}	Output Power (Duty Factor ≤ 2.7%)	250			mW
R _{IO}	Insulation Resistance at T _S , V _{IO} = 500V	10 ⁹			Ω

Absolute Maximum Ratings ($T_A = 25^\circ\text{C}$ unless otherwise specified)

Stresses exceeding the absolute maximum ratings may damage the device. The device may not function or be operable above the recommended operating conditions and stressing the parts to these levels is not recommended. In addition, extended exposure to stresses above the recommended operating conditions may affect device reliability. The absolute maximum ratings are stress ratings only.

Symbol	Parameter	Value	Units
T_{STG}	Storage Temperature	-55 to +125	$^\circ\text{C}$
T_{OPR}	Operating Temperature	-40 to +100	$^\circ\text{C}$
T_J	Junction Temperature	-40 to +125	$^\circ\text{C}$
T_{SOL}	Lead Wave Solder Temperature (refer to page 21 for reflow solder profile)	260 for 10sec	$^\circ\text{C}$
$I_{F(AVG)}$	Average Input Current	25	mA
$I_{F(PEAK)}$	Peak Transient Forward Current ⁽¹⁰⁾	1	A
f	Operating Frequency ⁽¹¹⁾	50	kHz
V_R	Reverse Input Voltage	5	V
$I_{O(PEAK)}$	Peak Output Current ⁽¹⁾	3.0	A
$V_{CC} - V_{EE}$	Supply Voltage	$T_A \leq 90^\circ\text{C}$	0 to 35
		$T_A \geq 90^\circ\text{C}$	0 to 30
$V_{O(PEAK)}$	Peak Output Voltage	0 to V_{CC}	V
$t_{R(IN)}, t_{F(IN)}$	Input Signal Rise and Fall Time	500	ns
PD_I	Input Power Dissipation ⁽²⁾⁽⁴⁾	45	mW
PD_O	Output Power Dissipation ⁽³⁾⁽⁴⁾	250	mW

Recommended Operating Conditions

The Recommended Operating Conditions table defines the conditions for actual device operation. Recommended operating conditions are specified to ensure optimal performance to the datasheet specifications. Fairchild does not recommend exceeding them or designing to absolute maximum ratings.

Symbol	Parameter	Value	Units
T_A	Ambient Operating Temperature	-40 to +100	$^\circ\text{C}$
$V_{CC} - V_{EE}$	Power Supply	15 to 30	V
$I_{F(ON)}$	Input Current (ON)	7 to 16	mA
$V_{F(OFF)}$	Input Voltage (OFF)	0 to 0.8	V

Isolation Characteristics

Apply over all recommended conditions, typical value is measured at $T_A = 25^\circ\text{C}$

Symbol	Parameter	Conditions	Min.	Typ.	Max.	Units
V_{ISO}	Input-Output Isolation Voltage	$T_A = 25^\circ\text{C}$, R.H. < 50%, $t = 1.0\text{min}$, $I_{I-O} \leq 10\mu\text{A}$, 50Hz ⁽⁵⁾⁽⁶⁾	5000			V_{RMS}
R_{ISO}	Isolation Resistance	$V_{I-O} = 500\text{V}$ ⁽⁵⁾		10^{11}		Ω
C_{ISO}	Isolation Capacitance	$V_{I-O} = 0\text{V}$, Freq = 1.0MHz ⁽⁵⁾		1		pF

Electrical Characteristics

Apply over all recommended conditions, typical value is measured at $V_{CC} = 30V$, $V_{EE} = \text{Ground}$, $T_A = 25^\circ\text{C}$ unless otherwise specified.

Symbol	Parameter	Conditions	Min.	Typ.	Max.	Units
V_F	Input Forward Voltage	$I_F = 10\text{mA}$	1.2	1.5	1.8	V
$\Delta(V_F / T_A)$	Temperature Coefficient of Forward Voltage			-1.8		mV/°C
BV_R	Input Reverse Breakdown Voltage	$I_R = 10\mu\text{A}$	5			V
C_{IN}	Input Capacitance	$f = 1\text{MHz}$, $V_F = 0V$		60		pF
I_{OH}	High Level Output Current ⁽¹⁾	$V_O = V_{CC} - 3V$	-1	-2.0	-2.5	A
		$V_O = V_{CC} - 6V$	-2.0		-2.5	
I_{OL}	Low Level Output Current ⁽¹⁾	$V_O = V_{EE} + 3V$	1	2.0	2.5	A
		$V_O = V_{EE} + 6V$	2.0		2.5	
V_{OH}	High Level Output Voltage	$I_F = 10\text{mA}$, $I_O = -2.5\text{A}$	$V_{CC} - 6.25V$	$V_{CC} - 2.5V$		V
		$I_F = 10\text{mA}$, $I_O = -100\text{mA}$	$V_{CC} - 0.25V$	$V_{CC} - 0.1V$		
V_{OL}	Low Level Output Voltage	$I_F = 0\text{mA}$, $I_O = 2.5\text{A}$		$V_{EE} + 2.5V$	$V_{EE} + 6.25V$	V
		$I_F = 0\text{mA}$, $I_O = 100\text{mA}$		$V_{EE} + 0.1V$	$V_{EE} + 0.25V$	
I_{CCH}	High Level Supply Current	$V_O = \text{Open}$, $I_F = 7$ to 16mA		2.8	3.8	mA
I_{CCL}	Low Level Supply Current	$V_O = \text{Open}$, $V_F = 0$ to $0.8V$		2.8	3.8	mA
I_{FLH}	Threshold Input Current Low to High	$I_O = 0\text{mA}$, $V_O > 5V$		2.3	5.0	mA
V_{FHL}	Threshold Input Voltage High to Low	$I_O = 0\text{mA}$, $V_O < 5V$	0.8			V
V_{UVLO+}	Under Voltage Lockout Threshold	$I_F = 10\text{mA}$, $V_O > 5V$	11.5	12.7	13.5	V
V_{UVLO-}		$I_F = 10\text{mA}$, $V_O < 5V$	10.0	11.2	12.0	V
$UVLO_{HYS}$	Under Voltage Lockout Threshold Hysteresis			1.5		V

Switching Characteristics

Apply over all recommended conditions, typical value is measured at $V_{CC} = 30V$, $V_{EE} = \text{Ground}$, $T_A = 25^\circ\text{C}$ unless otherwise specified.

Symbol	Parameter	Conditions	Min.	Typ.	Max.	Units
t_{PHL}	Propagation Delay Time to Logic Low Output	$I_F = 7\text{mA to } 16\text{mA}$, $R_g = 10\Omega$, $C_g = 10\text{nF}$, $f = 10\text{kHz}$, Duty Cycle = 50%	150	275	400	ns
t_{PLH}	Propagation Delay Time to Logic High Output		150	255	400	ns
PWD	Pulse Width Distortion, $ t_{PHL} - t_{PLH} $			20	100	ns
PDD (Skew)	Propagation Delay Difference Between Any Two Parts or Channels, $(t_{PHL} - t_{PLH})^{(7)}$			-250	250	ns
t_r	Output Rise Time (10% – 90%)				60	ns
t_f	Output Fall Time (90% – 10%)				60	ns
$t_{UVLO\ ON}$	UVLO Turn On Delay		$I_F = 10\text{mA}$, $V_O > 5V$		1.6	
$t_{UVLO\ OFF}$	UVLO Turn Off Delay	$I_F = 10\text{mA}$, $V_O < 5V$		0.4		μs
$ CM_H $	Common Mode Transient Immunity at Output High	$T_A = 25^\circ\text{C}$, $V_{CC} = 30V$, $I_F = 7 \text{ to } 16\text{mA}$, $V_{CM} = 2000V^{(8)}$	35	50		$\text{kV}/\mu\text{s}$
$ CM_L $	Common Mode Transient Immunity at Output Low	$T_A = 25^\circ\text{C}$, $V_{CC} = 30V$, $V_F = 0V$, $V_{CM} = 2000V^{(9)}$	35	50		$\text{kV}/\mu\text{s}$

Notes:

- Maximum pulse width = $10\mu\text{s}$, maximum duty cycle = 1.1%
- Derate linearly above 87°C , free air temperature at a rate of $0.77\text{mW}/^\circ\text{C}$
- No derating required across temperature range.
- Functional operation under these conditions is not implied. Permanent damage may occur if the device is subjected to conditions outside these ratings.
- Device is considered a two terminal device: Pins 2 and 3 are shorted together and Pins 5, 6, 7 and 8 are shorted together.
- $5,000 V_{RMS}$ for 1 minute duration is equivalent to $6,000 V_{AC\ RMS}$ for 1 second duration.
- The difference between t_{PHL} and t_{PLH} between any two FOD3120 parts under same test conditions.
- Common mode transient immunity at output high is the maximum tolerable negative dV_{cm}/dt on the trailing edge of the common mode impulse signal, V_{cm} , to assure that the output will remain high (i.e. $V_O > 15.0V$).
- Common mode transient immunity at output low is the maximum tolerable positive dV_{cm}/dt on the leading edge of the common pulse signal, V_{cm} , to assure that the output will remain low (i.e. $V_O < 1.0V$).
- Pulse Width, $P_W \leq 1\mu\text{s}$, 300pps
- Exponential Waveform, $I_{O(PEAK)} \leq |2.5A| (\leq 0.3\mu\text{s})$

Typical Performance Curves

Fig. 1 Output High Voltage Drop vs. Output High Current

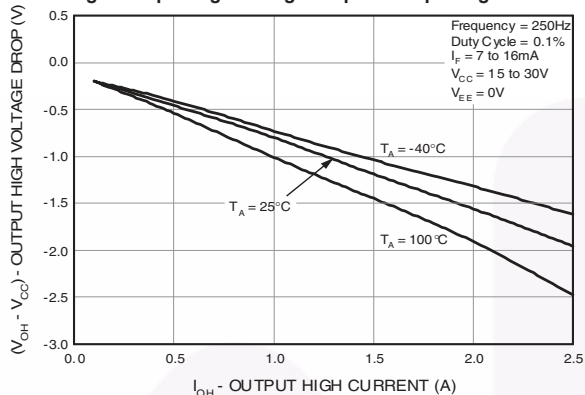

Fig. 2 Output High Voltage Drop vs. Ambient Temperature

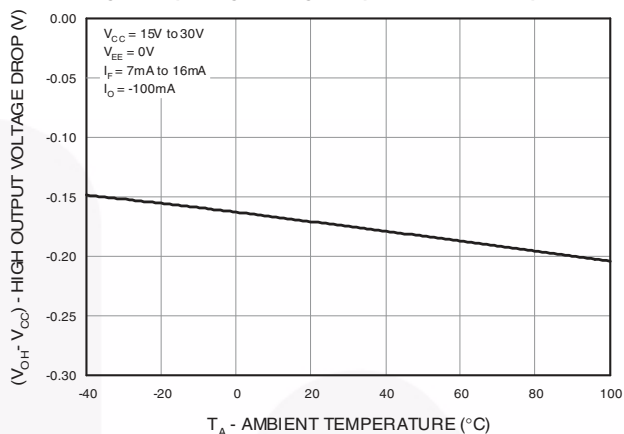

Fig. 3 Output High Current vs. Ambient Temperature

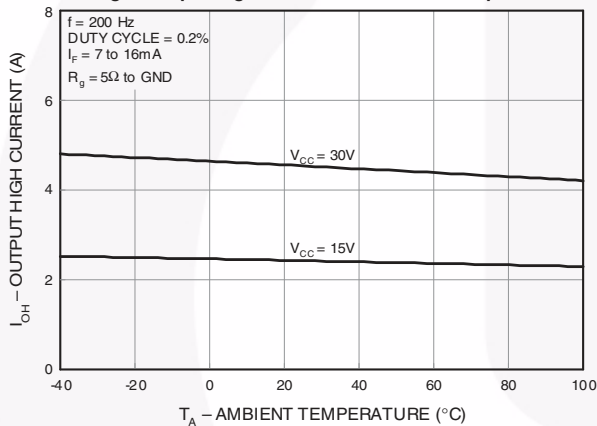

Fig. 4 Output High Current vs. Ambient Temperature

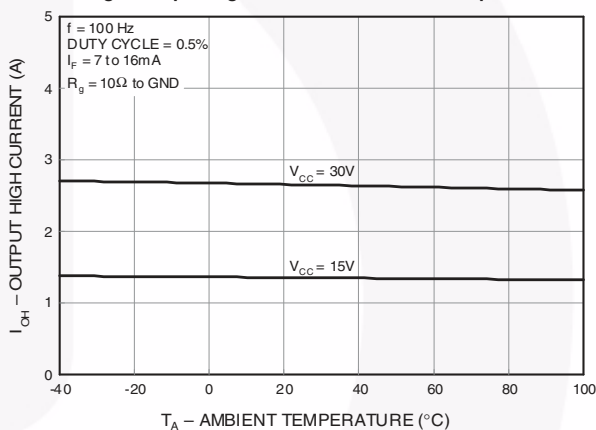

Fig. 5 Output Low Voltage vs. Output Low Current

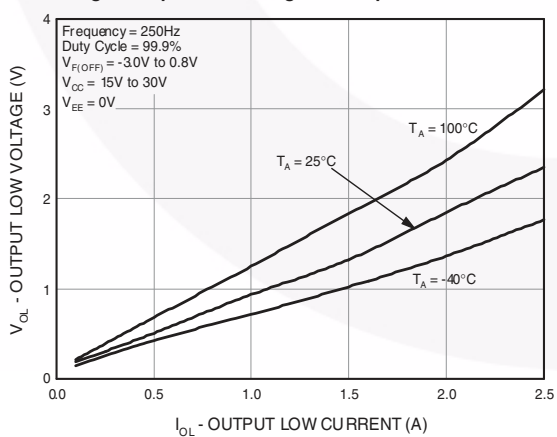
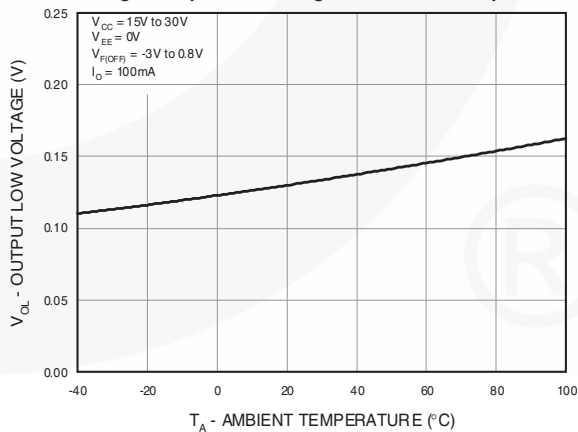

Fig. 6 Output Low Voltage vs. Ambient Temperature



Typical Performance Curves (Continued)

Fig. 7 Output Low Current vs. Ambient Temperature

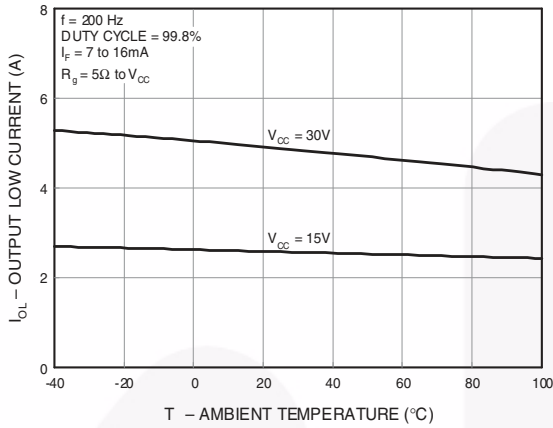

Fig. 8 Output Low Current vs. Ambient Temperature

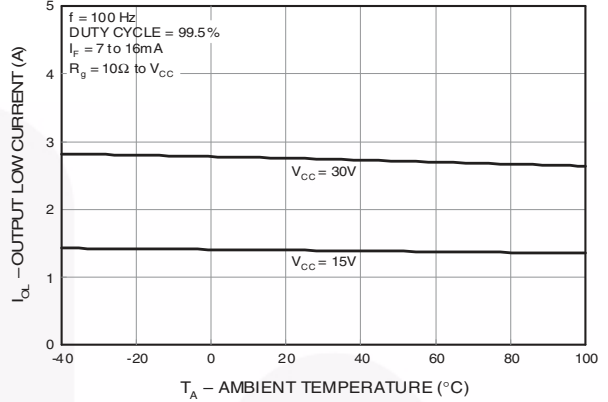

Fig. 9 Supply Current vs. Ambient Temperature

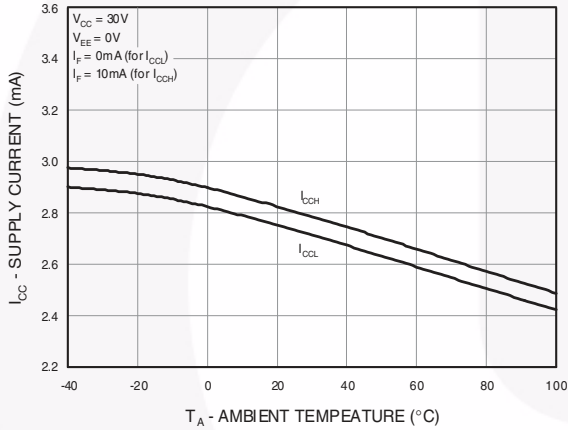

Fig. 10 Supply Current vs. Supply Voltage

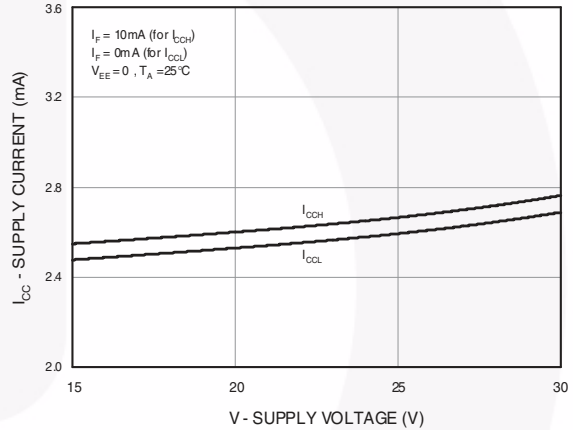

Fig. 11 Low to High Input Current Threshold vs. Ambient Temperature

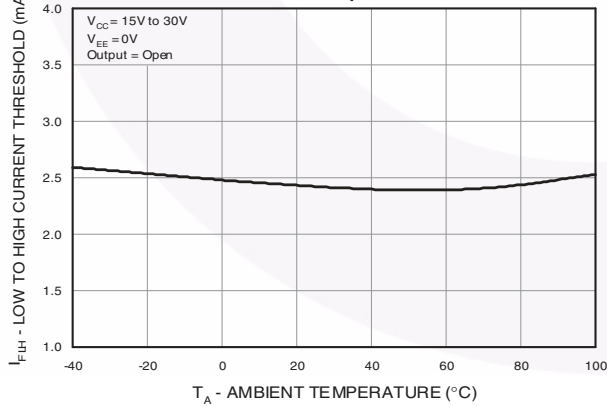
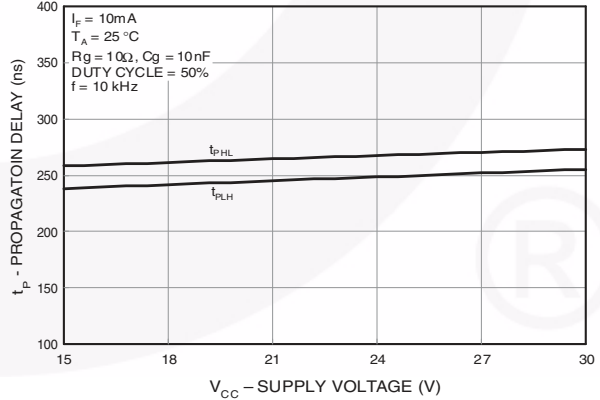

Fig. 12 Propagation Delay vs. Supply Voltage



Typical Performance Curves (Continued)

Fig. 13 Propagation Delay vs. LED Forward Current

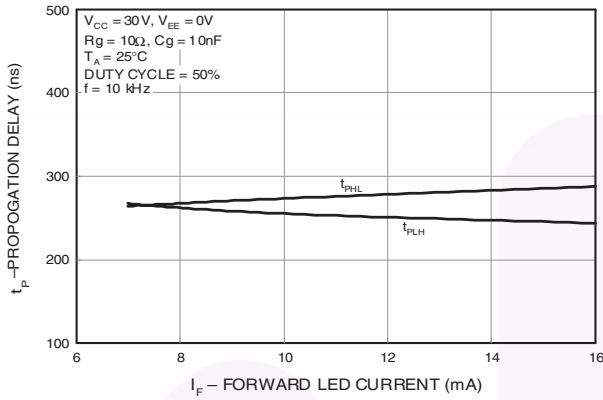

Fig. 14 Propagation Delay vs. Ambient Temperature

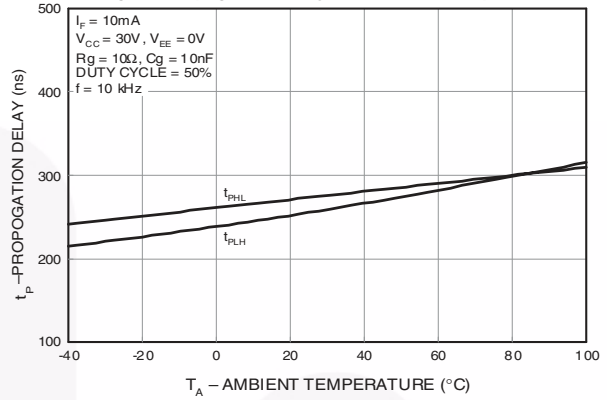

Fig. 15 Propagation Delay vs. Series Load Resistance

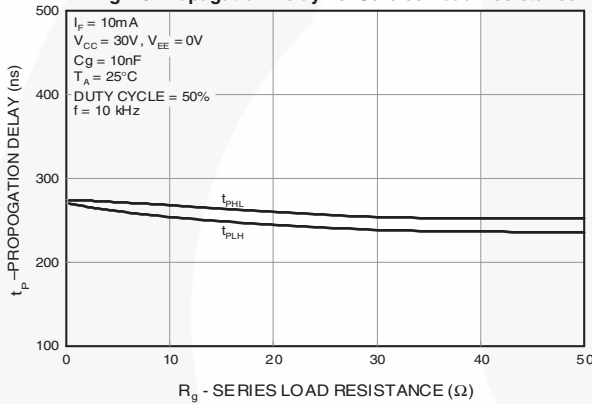

Fig. 16 Propagation Delay vs. Load Capacitance

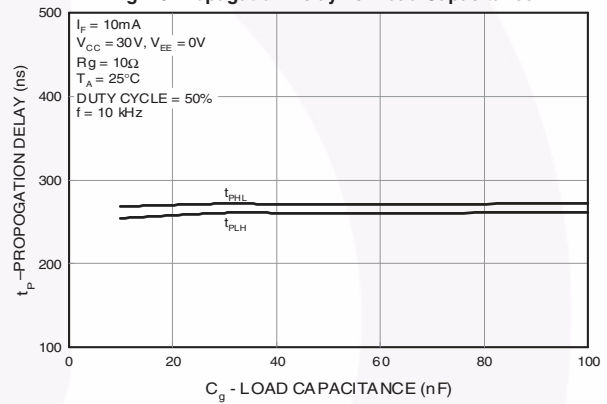

Fig. 17 Transfer Characteristics

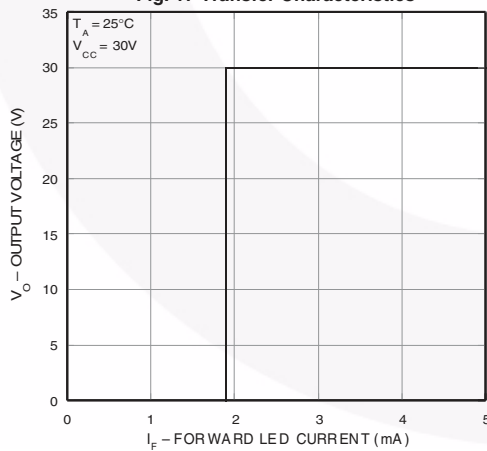
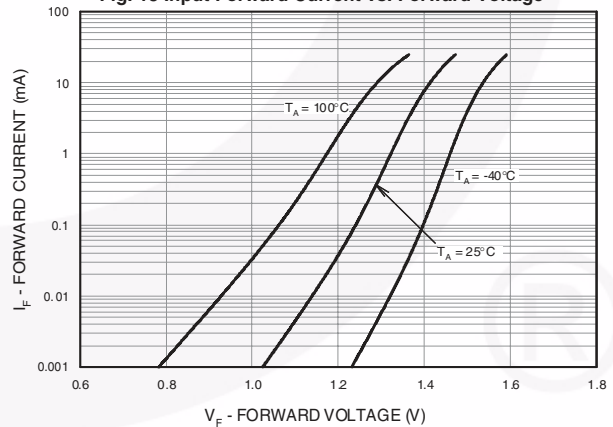
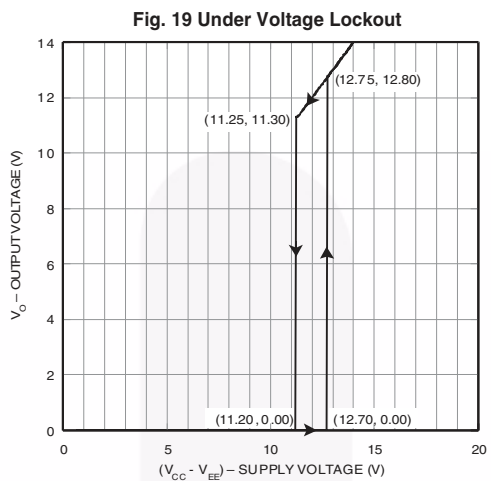

Fig. 18 Input Forward Current vs. Forward Voltage



Typical Performance Curves (Continued)



Test Circuit

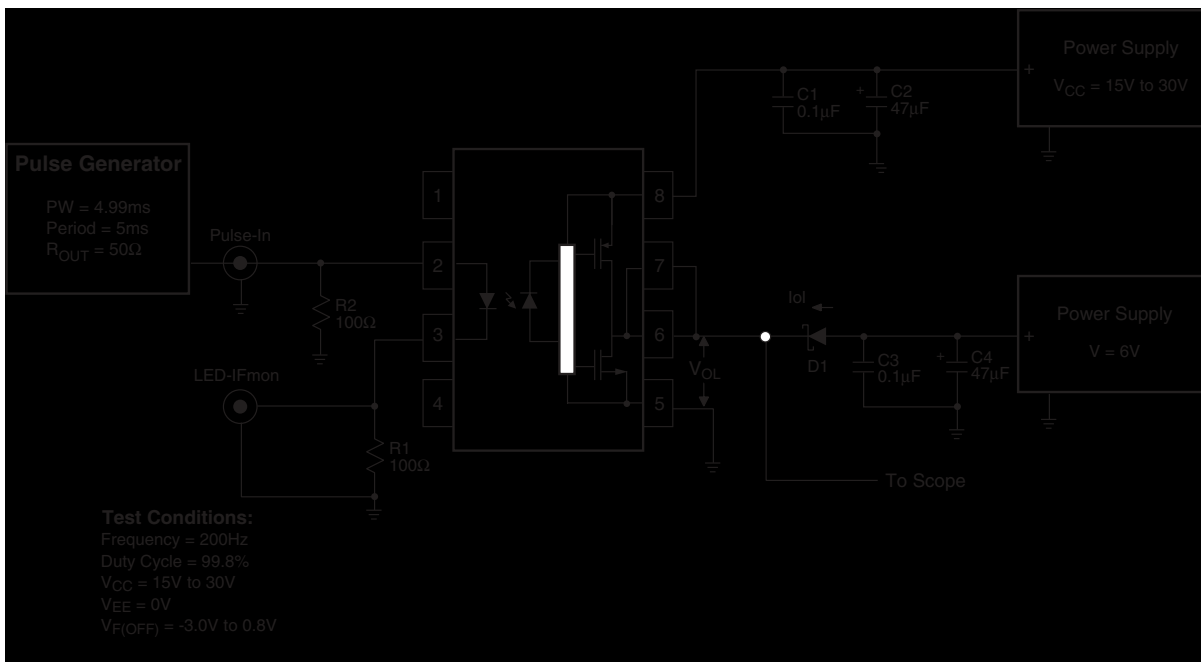

Figure 20. I_{OL} Test Circuit

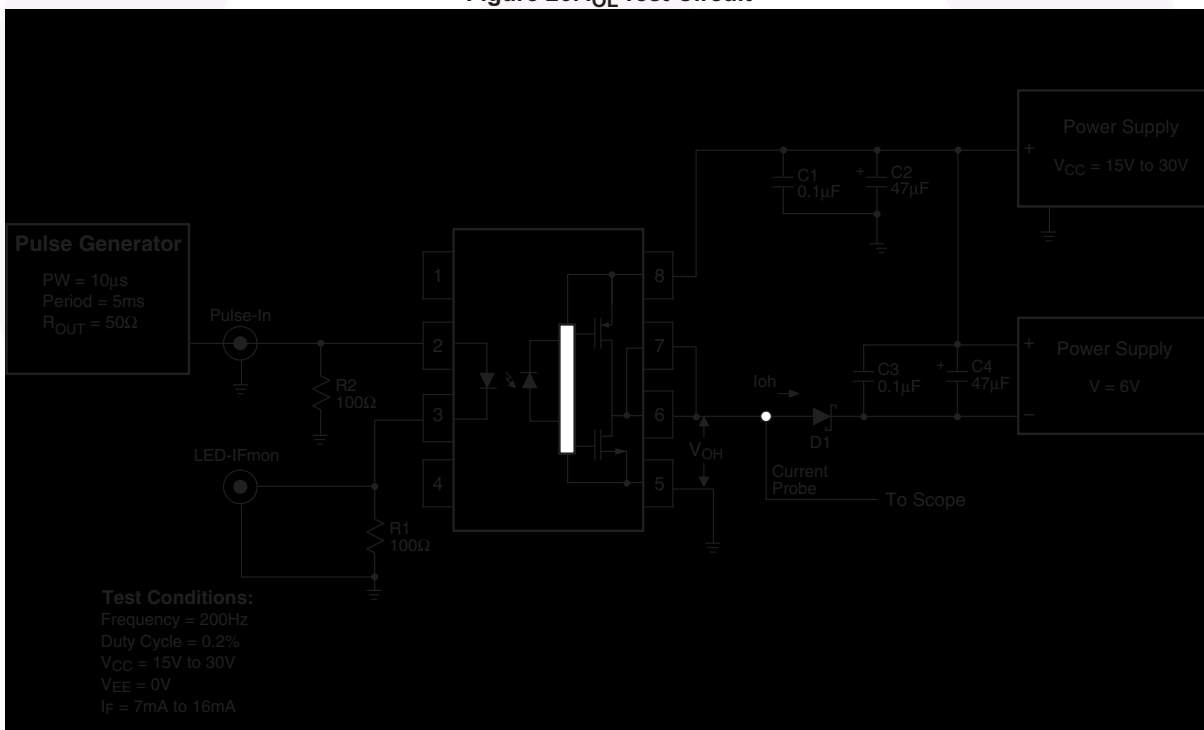

Figure 21. I_{OH} Test Circuit

Test Circuit (Continued)

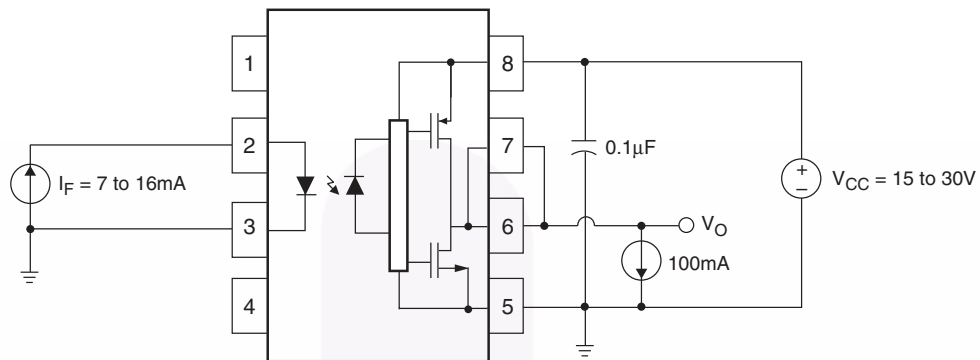

Figure 22. V_{OH} Test Circuit

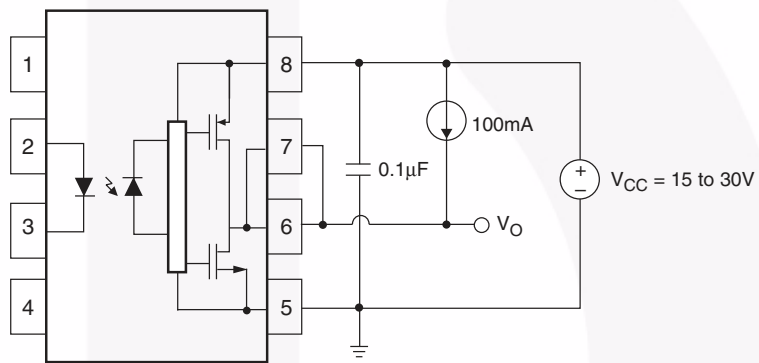

Figure 23. V_{OL} Test Circuit



Test Circuit (Continued)

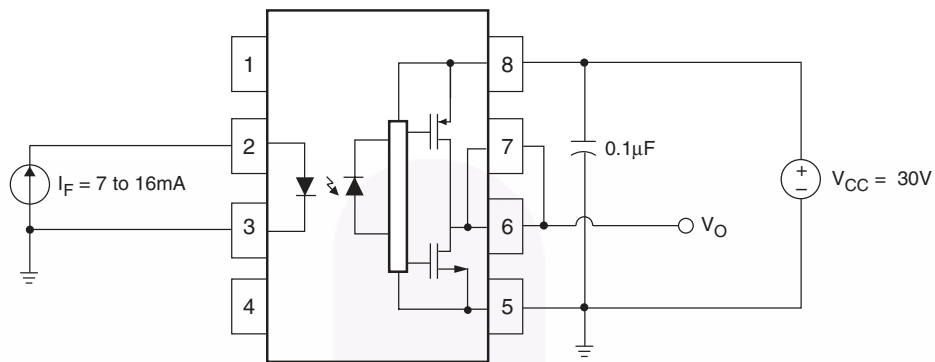

Figure 24. I_{CCH} Test Circuit

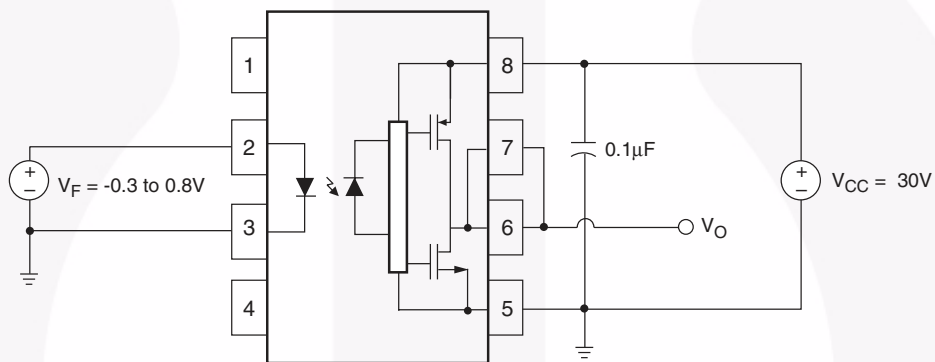

Figure 25. I_{CCL} Test Circuit



Test Circuit (Continued)

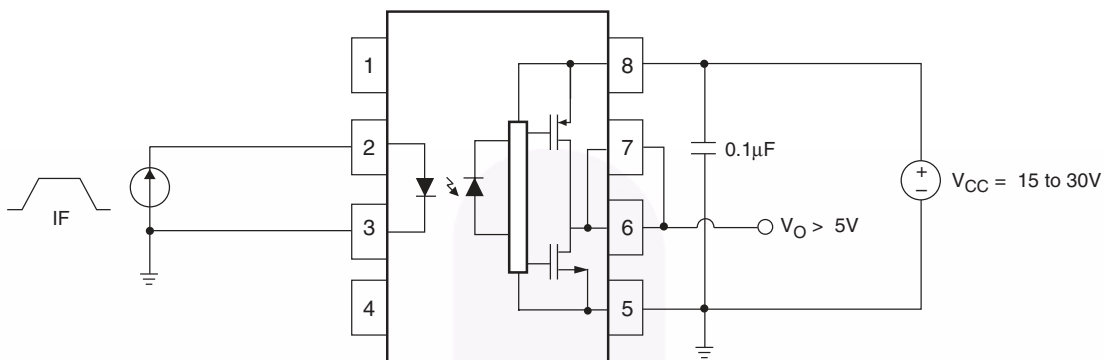

Figure 26. I_{FLH} Test Circuit

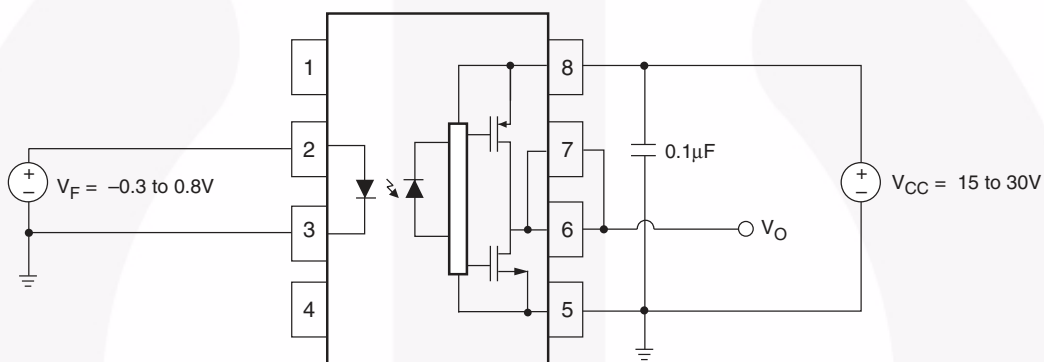

Figure 27. V_{FHL} Test Circuit

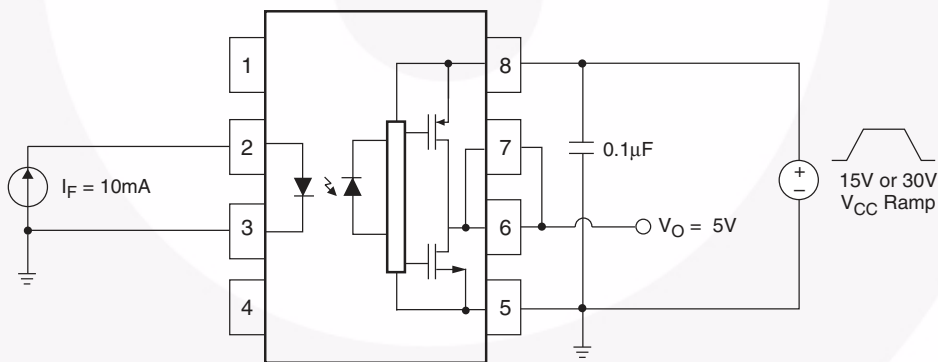

Figure 28. UVLO Test Circuit

Test Circuit (Continued)

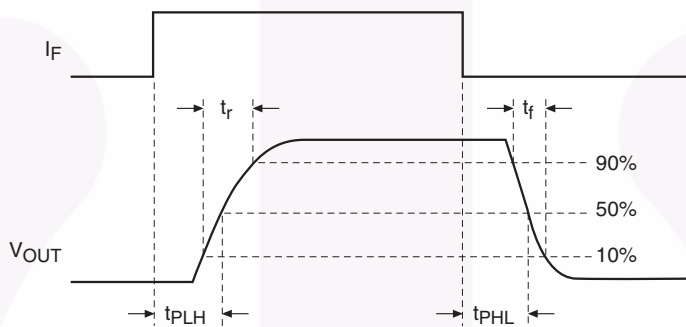
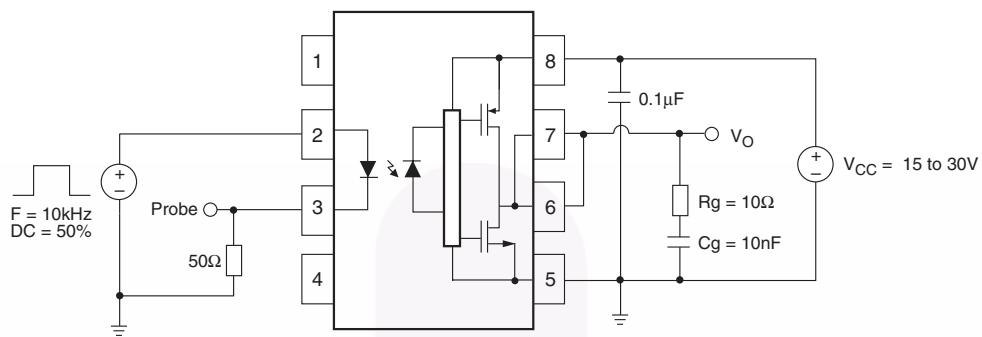

Figure 29. t_{pHL} , t_{pLH} , t_R and t_F Test Circuit and Waveforms

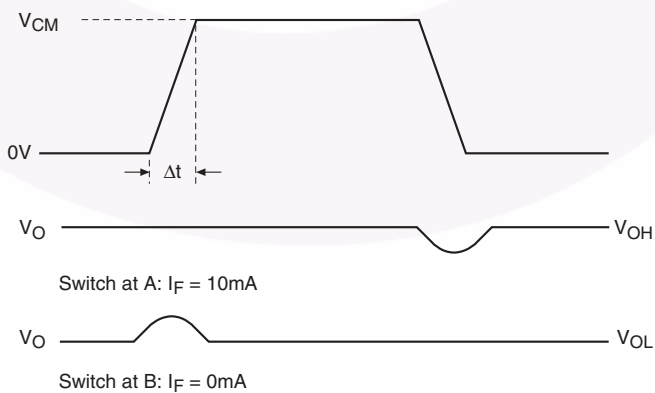
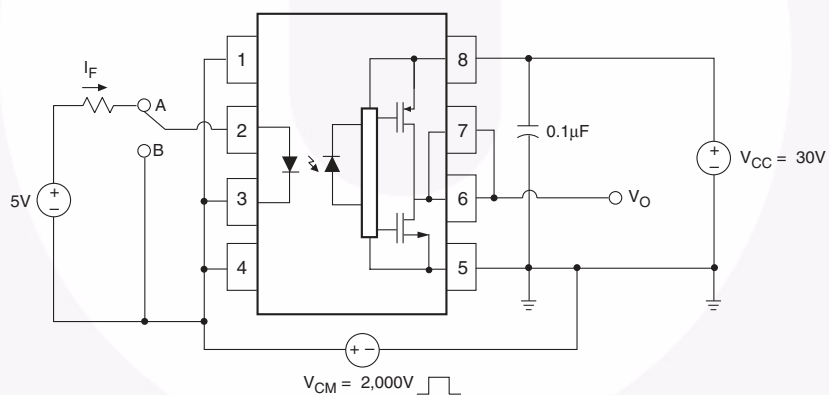
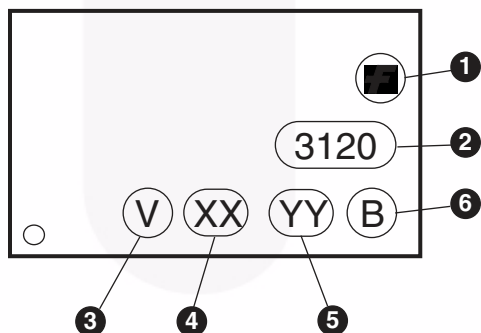

Figure 30. CMR Test Circuit and Waveforms

Ordering Information

Part Number	Package	Packing Method
FOD3120	DIP 8-Pin	Tube (50 units per tube)
FOD3120S	SMT 8-Pin (Lead Bend)	Tube (50 units per tube)
FOD3120SD	SMT 8-Pin (Lead Bend)	Tape and Reel (1,000 units per reel)
FOD3120V	DIP 8-Pin, IEC60747-5-2 option	Tube (50 units per tube)
FOD3120SV	SMT 8-Pin (Lead Bend), IEC60747-5-2 option	Tube (50 units per tube)
FOD3120SDV	SMT 8-Pin (Lead Bend), IEC60747-5-2 option	Tape and Reel (1,000 units per reel)
FOD3120T	DIP 8-Pin, 0.4" Lead Spacing	Tube (50 units per tube)
FOD3120TV	DIP 8-Pin, 0.4" Lead Spacing, IEC60747-5-2 option	Tube (50 units per tube)
FOD3120TS	SMT 8-Pin, 0.4" Lead Spacing	Tube (50 units per tube)
FOD3120TSV	SMT 8-Pin, 0.4" Lead Spacing, IEC60747-5-2 option	Tube (50 units per tube)
FOD3120TSR2	SMT 8-Pin, 0.4" Lead Spacing	Tape and Reel (700 units per reel)
FOD3120TSR2V	SMT 8-Pin, 0.4" Lead Spacing, IEC60747-5-2 option	Tape and Reel (700 units per reel)

Marking Information



Definitions	
1	Fairchild logo
2	Device number
3	IEC60747-5-2 Option (only appears on component ordered with this option) (Pending approval)
4	Two digit year code, e.g., '08'
5	Two digit work week ranging from '01' to '53'
6	Assembly package code

Carrier Tape Specifications (Option SD)

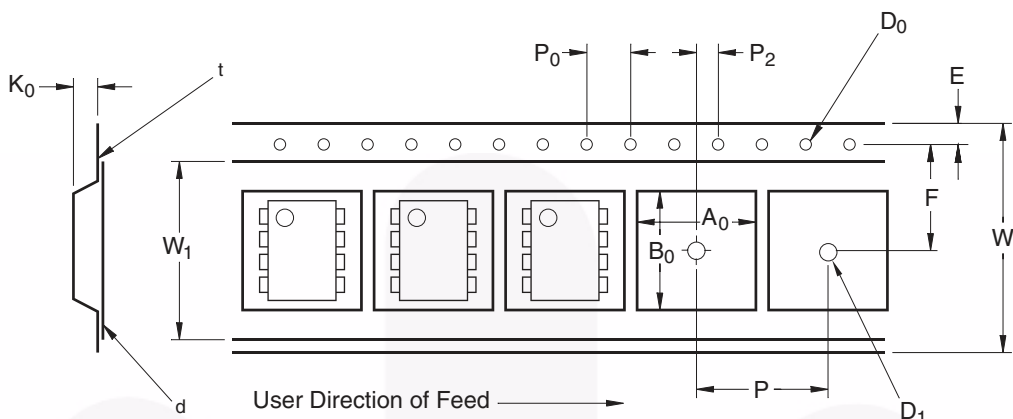

Symbol	Description	Dimension in mm
W	Tape Width	16.0 ± 0.3
t	Tape Thickness	0.30 ± 0.05
P ₀	Sprocket Hole Pitch	4.0 ± 0.1
D ₀	Sprocket Hole Diameter	1.55 ± 0.05
E	Sprocket Hole Location	1.75 ± 0.10
F	Pocket Location	7.5 ± 0.1
P ₂		2.0 ± 0.1
P	Pocket Pitch	12.0 ± 0.1
A ₀	Pocket Dimensions	10.30 ± 0.20
B ₀		10.30 ± 0.20
K ₀		4.90 ± 0.20
W ₁	Cover Tape Width	13.2 ± 0.2
d	Cover Tape Thickness	0.1 max
	Max. Component Rotation or Tilt	10°
R	Min. Bending Radius	30

Carrier Tape Specifications (Option TSR2)

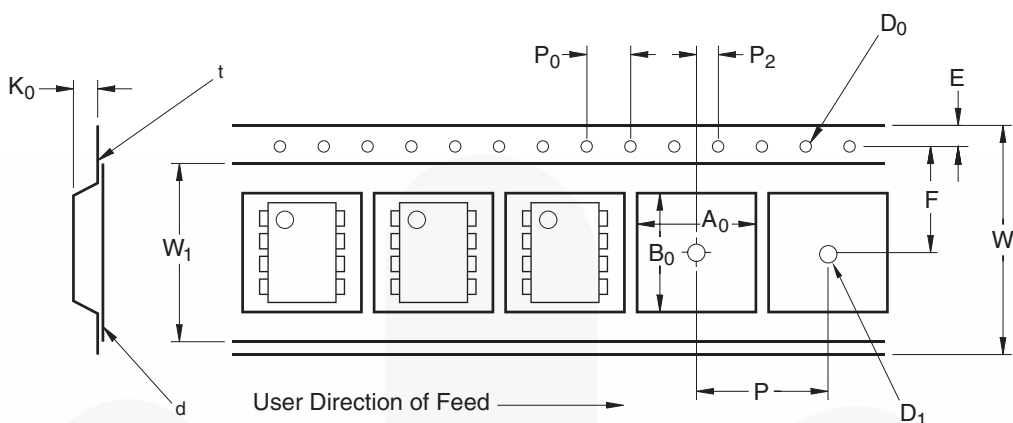

Symbol	Description	Dimension in mm
W	Tape Width	24.0 ± 0.3
t	Tape Thickness	0.40 ± 0.1
P ₀	Sprocket Hole Pitch	4.0 ± 0.1
D ₀	Sprocket Hole Diameter	1.55 ± 0.05
E	Sprocket Hole Location	1.75 ± 0.10
F	Pocket Location	11.5 ± 0.1
P ₂		2.0 ± 0.1
P	Pocket Pitch	16.0 ± 0.1
A ₀	Pocket Dimensions	12.80 ± 0.1
B ₀		10.35 ± 0.1
K ₀		5.7 ± 0.1
W ₁	Cover Tape Width	21.0 ± 0.1
d	Cover Tape Thickness	0.1 max
	Max. Component Rotation or Tilt	10°
R	Min. Bending Radius	30

Reflow Profile

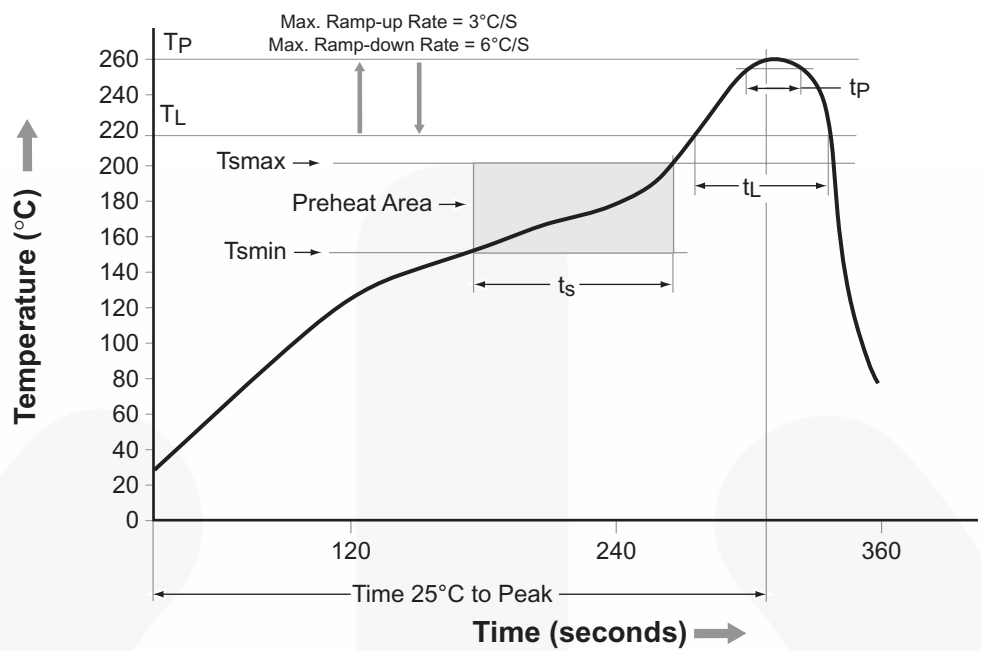

Profile Feature	Pb-Free Assembly Profile
Temperature Min. (Tsmín)	150°C
Temperature Max. (Tsmáx)	200°C
Time (ts) from (Tsmín to Tsmáx)	60–120 seconds
Ramp-up Rate (tL to tp)	3°C/second max.
Liquidous Temperature (TL)	217°C
Time (tL) Maintained Above (TL)	60–150 seconds
Peak Body Package Temperature	260°C +0°C / -5°C
Time (tp) within 5°C of 260°C	30 seconds
Ramp-down Rate (TP to TL)	6°C/second max.
Time 25°C to Peak Temperature	8 minutes max.

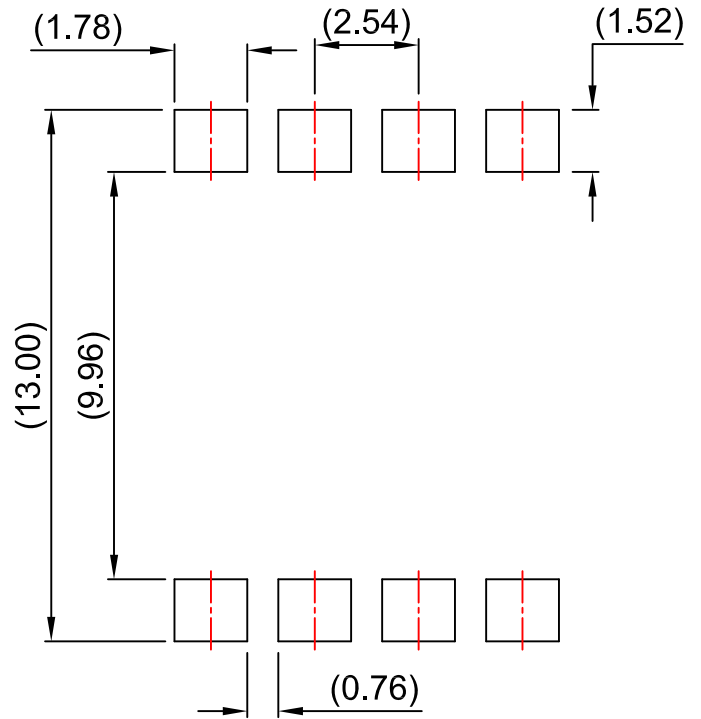
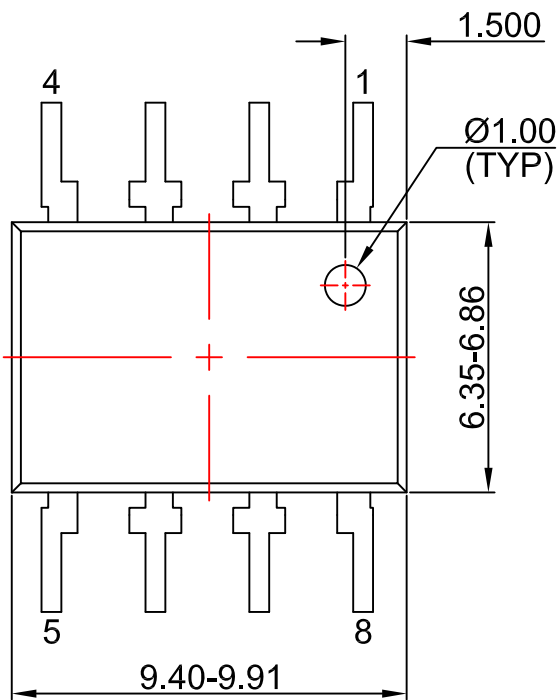

LAND PATTERN RECOMMENDATION

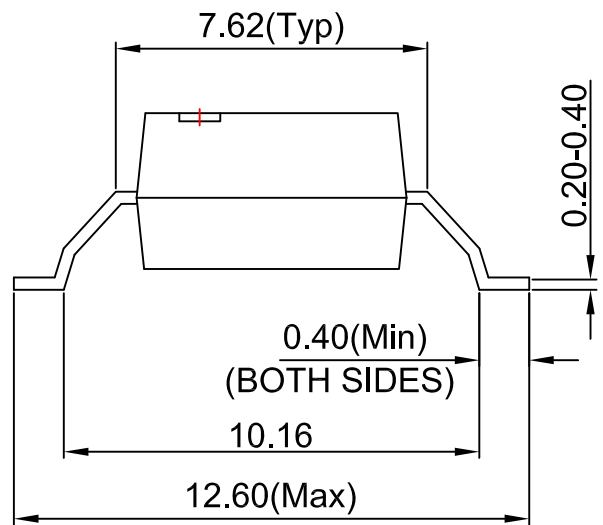
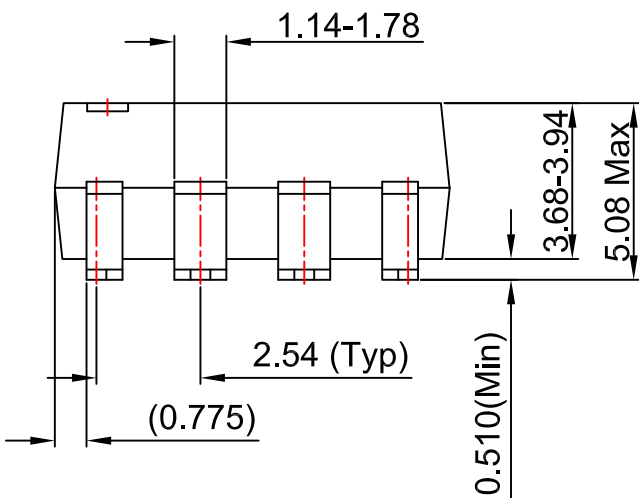

NOTES:

- A) NO STANDARD APPLIES TO THIS PACKAGE
- B) ALL DIMENSIONS ARE IN MILLIMETERS.
- C) DIMENSIONS ARE EXCLUSIVE OF BURRS, MOLD FLASH, AND TIE BAR EXTRUSION
- D) DWG FILENAME AND REVISION: MKT-N08Lrev2.



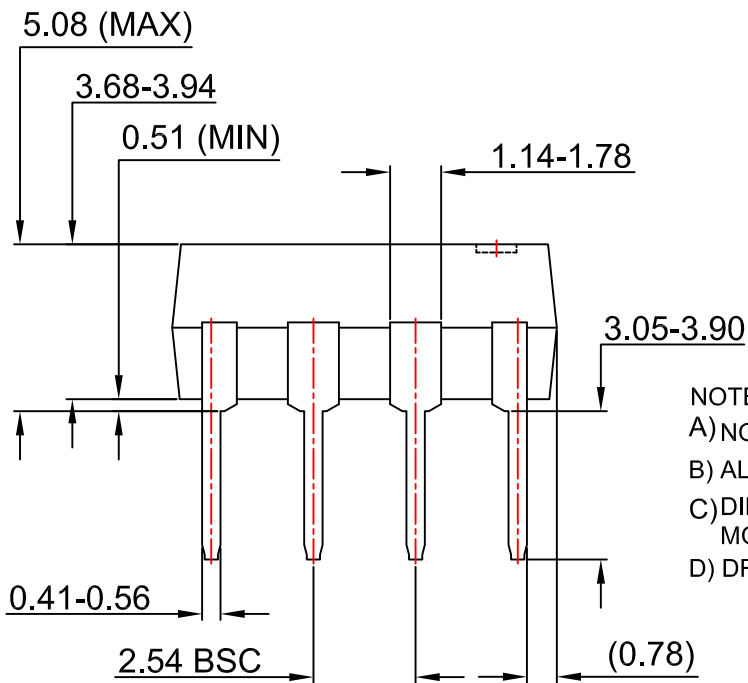
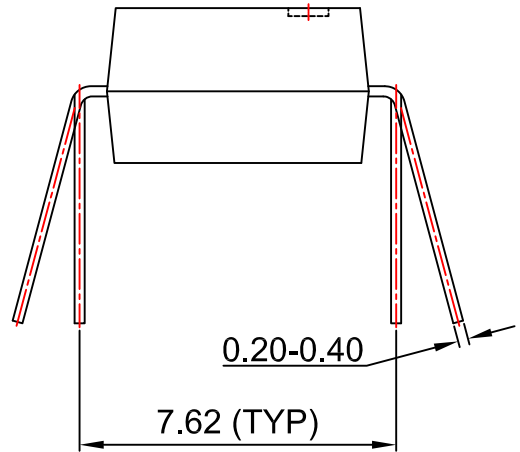
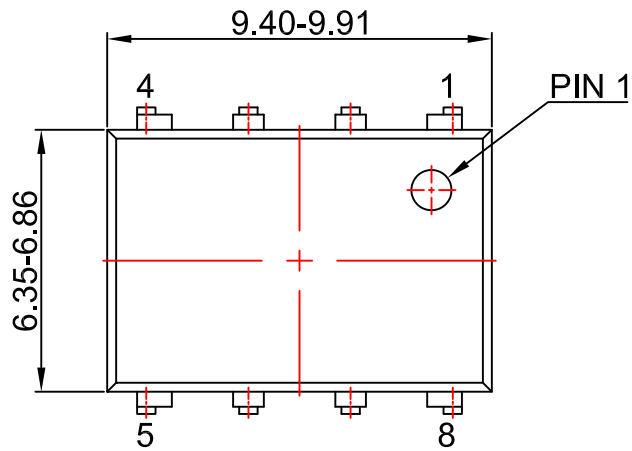

- NOTES:
- A) NO STANDARD APPLIES TO THIS PACKAGE
 - B) ALL DIMENSIONS ARE IN MILLIMETERS.
 - C) DIMENSIONS ARE EXCLUSIVE OF BURRS, MOLD FLASH, AND TIE BAR EXTRUSION
 - D) DRAWING FILENAME AND REVISION: MKT-N08GREV7



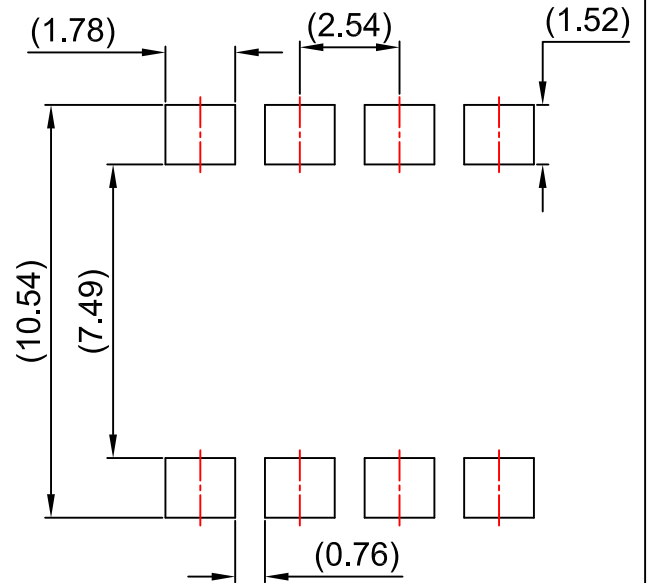
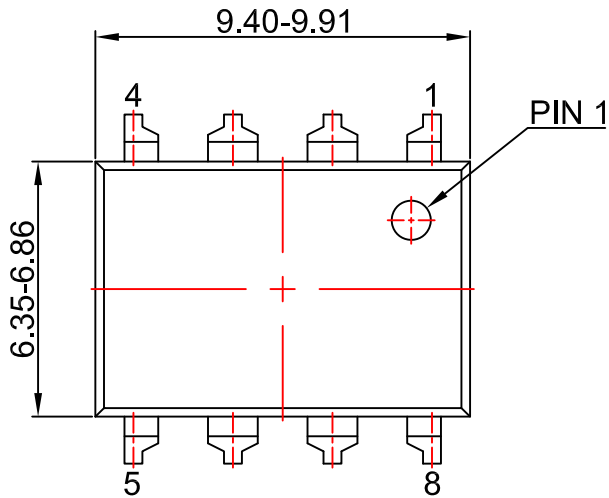

LAND PATTERN RECOMMENDATION

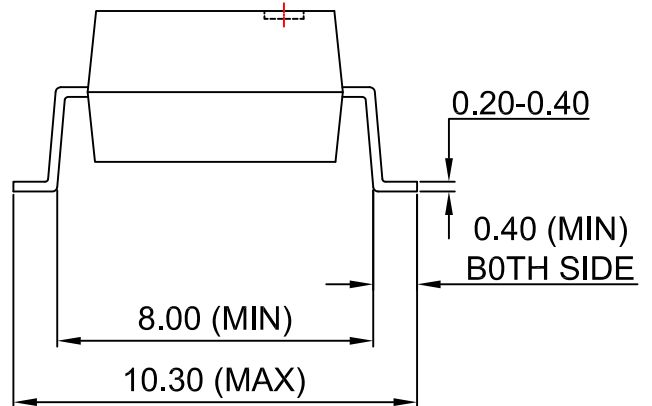
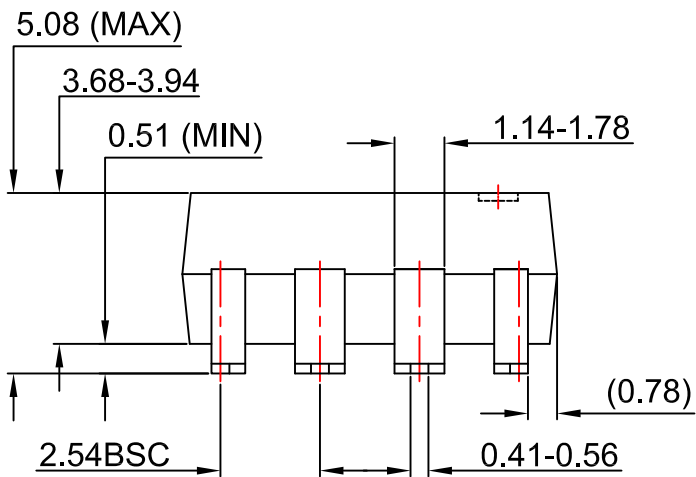

NOTES:

- A) NO STANDARD APPLIES TO THIS PACKAGE
- B) ALL DIMENSIONS ARE IN MILLIMETERS.
- C) DIMENSIONS ARE EXCLUSIVE OF BURRS, MOLD FLASH, AND TIE BAR EXTRUSION
- D) DRAWING FILENAME AND REVISION: MKT-N08Hrev7.



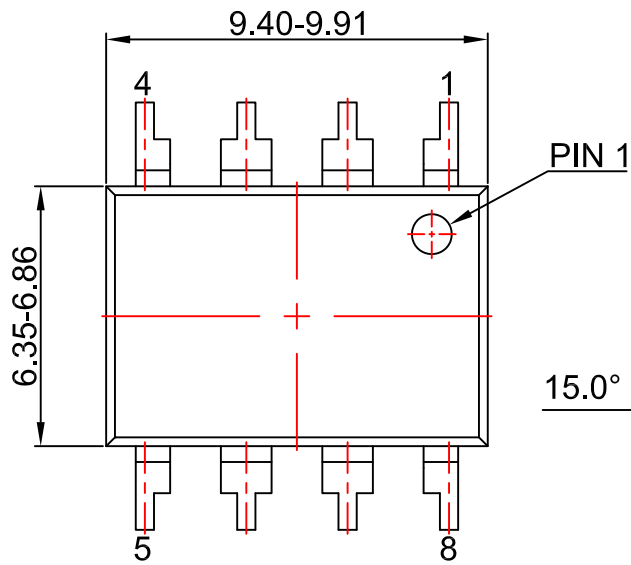

PIN 1

15.0° (MAX)

10.16 (TYP)

0.20-0.40

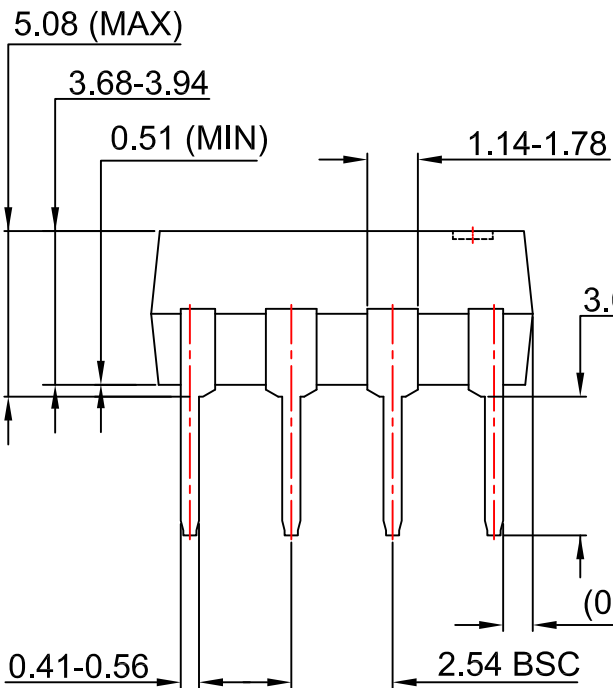

NOTES:





- A) NO STANDARD APPLIES TO THIS PACKAGE
- B) ALL DIMENSIONS ARE IN MILLIMETERS.
- C) DIMENSIONS ARE EXCLUSIVE OF BURRS, MOLD FLASH, AND TIE BAR EXTRUSION
- D) DRAWING FILENAME AND REVISION: MKT-N08REV7





TRADEMARKS

The following includes registered and unregistered trademarks and service marks, owned by Fairchild Semiconductor and/or its global subsidiaries, and is not intended to be an exhaustive list of all such trademarks.

- | | | | |
|---|--|---|---|
| AccuPower™ | F-PFS™ | OPTOPLANAR® |  |
| AttitudeEngine™ | FRFET® |  | TinyBoost® |
| Awinda® | Global Power Resource SM | PowerTrench® | TinyBuck® |
| AX-CAP®* | GreenBridge™ | PowerXS™ | TinyCalc™ |
| BitSiC™ | Green FPS™ | Programmable Active Droop™ | TinyLogic® |
| Build it Now™ | Green FPS™ e-Series™ | QFET® | TINYOPTO™ |
| CorePLUS™ | Gmax™ | QS™ | TinyPower™ |
| CorePOWER™ | GTO™ | Quiet Series™ | TinyPWM™ |
| CROSSVOL™ | IntelliMAX™ | RapidConfigure™ | TinyWire™ |
| CTL™ | ISOPLANAR™ |  | TranSiC™ |
| Current Transfer Logic™ | Making Small Speakers Sound Louder and Better™ | Saving our world, 1mW/W/kW at a time™ | TriFault Detect™ |
| DEUXPEED® | MegaBuck™ | SignalWise™ | TRUECURRENT®* |
| Dual Cool™ | MICROCOUPLER™ | SmartMax™ | μSerDes™ |
| EcoSPARK® | MicroFET™ | SMART START™ |  |
| EfficientMax™ | MicroPak™ | Solutions for Your Success™ | UHC® |
| ESBC™ | MicroPak2™ | SPM® | Ultra FRFET™ |
|  | MillerDrive™ | STEALTH™ | UniFET™ |
| Fairchild® | MotionMax™ | SuperFET® | VCX™ |
| Fairchild Semiconductor® | MotionGrid® | SuperSOT™-3 | VisualMax™ |
| FACT Quiet Series™ | MTi® | SuperSOT™-6 | VoltagePlus™ |
| FACT® | MTX® | SuperSOT™-8 | XSTM |
| FastvCore™ | MVN® | SupreMOS® | Xsens™ |
| FETBench™ | mWSaver® | SyncFET™ | 仙童® |
| FPS™ | OptoHiT™ | Sync-Lock™ | |
| | OPTOLOGIC® | | |

* Trademarks of System General Corporation, used under license by Fairchild Semiconductor.

DISCLAIMER

FAIRCHILD SEMICONDUCTOR RESERVES THE RIGHT TO MAKE CHANGES WITHOUT FURTHER NOTICE TO ANY PRODUCTS HEREIN TO IMPROVE RELIABILITY, FUNCTION, OR DESIGN. TO OBTAIN THE LATEST, MOST UP-TO-DATE DATASHEET AND PRODUCT INFORMATION, VISIT OUR WEBSITE AT [HTTP://WWW.FAIRCHILDSEMI.COM](http://www.fairchildsemi.com). FAIRCHILD DOES NOT ASSUME ANY LIABILITY ARISING OUT OF THE APPLICATION OR USE OF ANY PRODUCT OR CIRCUIT DESCRIBED HEREIN; NEITHER DOES IT CONVEY ANY LICENSE UNDER ITS PATENT RIGHTS, NOR THE RIGHTS OF OTHERS. THESE SPECIFICATIONS DO NOT EXPAND THE TERMS OF FAIRCHILD'S WORLDWIDE TERMS AND CONDITIONS, SPECIFICALLY THE WARRANTY THEREIN, WHICH COVERS THESE PRODUCTS.

AUTHORIZED USE

Unless otherwise specified in this data sheet, this product is a standard commercial product and is not intended for use in applications that require extraordinary levels of quality and reliability. This product may not be used in the following applications, unless specifically approved in writing by a Fairchild officer: (1) automotive or other transportation, (2) military/aerospace, (3) any safety critical application – including life critical medical equipment – where the failure of the Fairchild product reasonably would be expected to result in personal injury, death or property damage. Customer's use of this product is subject to agreement of this Authorized Use policy. In the event of an unauthorized use of Fairchild's product, Fairchild accepts no liability in the event of product failure. In other respects, this product shall be subject to Fairchild's Worldwide Terms and Conditions of Sale, unless a separate agreement has been signed by both Parties.

ANTI-COUNTERFEITING POLICY

Fairchild Semiconductor Corporation's Anti-Counterfeiting Policy. Fairchild's Anti-Counterfeiting Policy is also stated on our external website, www.fairchildsemi.com, under Terms of Use

Counterfeiting of semiconductor parts is a growing problem in the industry. All manufacturers of semiconductor products are experiencing counterfeiting of their parts. Customers who inadvertently purchase counterfeit parts experience many problems such as loss of brand reputation, substandard performance, failed applications, and increased cost of production and manufacturing delays. Fairchild is taking strong measures to protect ourselves and our customers from the proliferation of counterfeit parts. Fairchild strongly encourages customers to purchase Fairchild parts either directly from Fairchild or from Authorized Fairchild Distributors who are listed by country on our web page cited above. Products customers buy either from Fairchild directly or from Authorized Fairchild Distributors are genuine parts, have full traceability, meet Fairchild's quality standards for handling and storage and provide access to Fairchild's full range of up-to-date technical and product information. Fairchild and our Authorized Distributors will stand behind all warranties and will appropriately address any warranty issues that may arise. Fairchild will not provide any warranty coverage or other assistance for parts bought from Unauthorized Sources. Fairchild is committed to combat this global problem and encourage our customers to do their part in stopping this practice by buying direct or from authorized distributors.

PRODUCT STATUS DEFINITIONS

Definition of Terms

Datasheet Identification	Product Status	Definition
Advance Information	Formative / In Design	Datasheet contains the design specifications for product development. Specifications may change in any manner without notice.
Preliminary	First Production	Datasheet contains preliminary data; supplementary data will be published at a later date. Fairchild Semiconductor reserves the right to make changes at any time without notice to improve design.
No Identification Needed	Full Production	Datasheet contains final specifications. Fairchild Semiconductor reserves the right to make changes at any time without notice to improve the design.
Obsolete	Not In Production	Datasheet contains specifications on a product that is discontinued by Fairchild Semiconductor. The datasheet is for reference information only.

Rev. I77