

LOC		DIST		REVISIONS			
P	LTR	DESCRIPTION	DATE	DWN	APVD		
R		REVISED PER ECO-15-016062	10NOV15	KG	CD		

- THIS RCPT. IS DESIGNED TO CONFORM TO THE LATEST ISSUE OF MIL-C-24308.
 - MAX WIRE INSUL TO BE USED WITH THIS RCPT IS .068 DIA.
 - STAINLESS STEEL RETENTION CLIPS ARE INCLUDED IN INSERTS.
 - THIS RCPT. WILL ACCEPT SIZE 20 SOCKET CONTACT M39029/63-368 OR ANY TYCO HD-20 SOCKET CONTACT. CONTACTS ORDERED SEPARATELY.
- ⑤ TYCO PART NO. MARKED ON CONNECTOR REPRESENTS KIT NUMBER WITH CONTACTS.
 - ⑥ UL/CSA DESIGNATION STAMPED IN THIS AREA, OPTIONAL.
 - ⑦ FINISH: CADMIUM PER QQ-P-416.
 - ⑧ FINISH: BRIGHT TIN PER ASTM-B-545 .000400-.000550 THK OVER COPPER PER AMS2418 .000050 MIN THK.

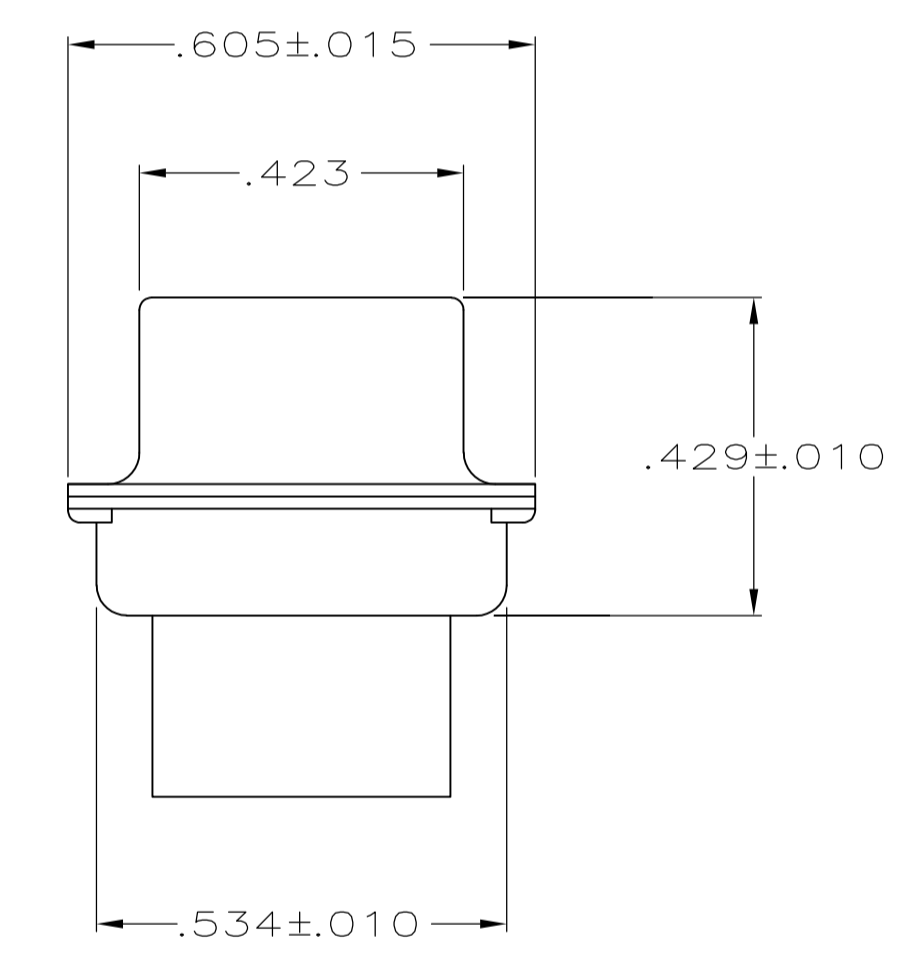
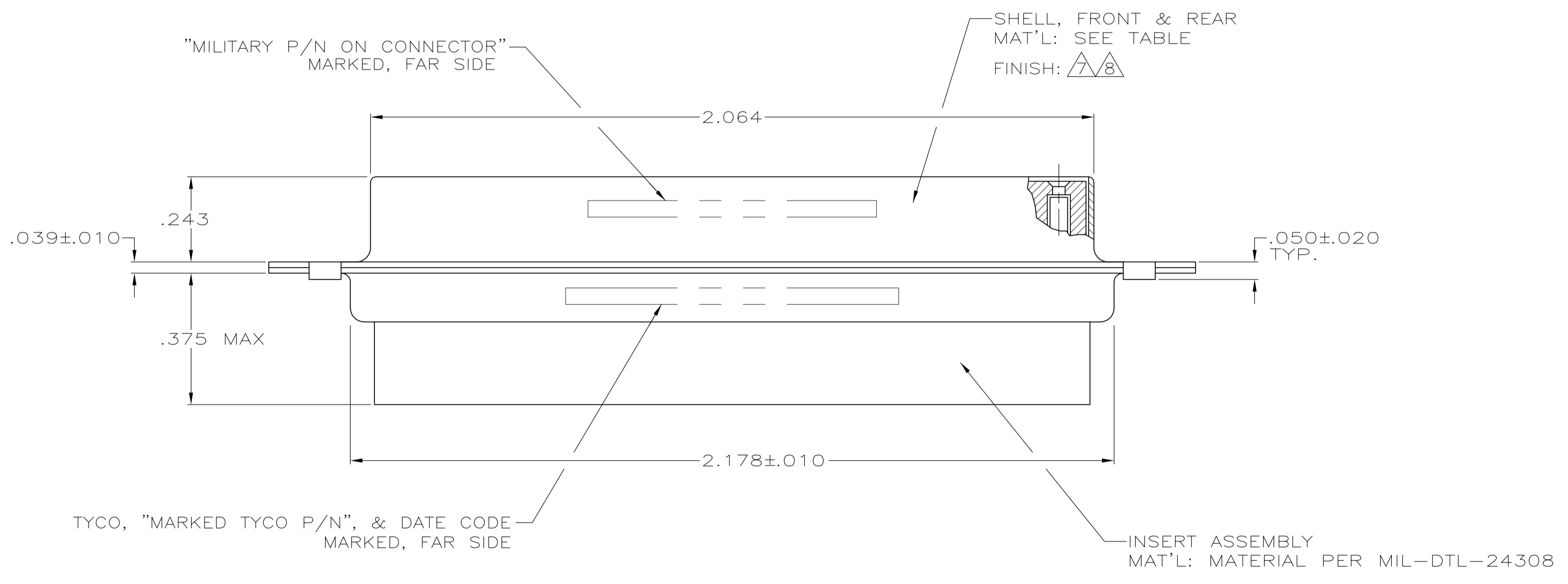
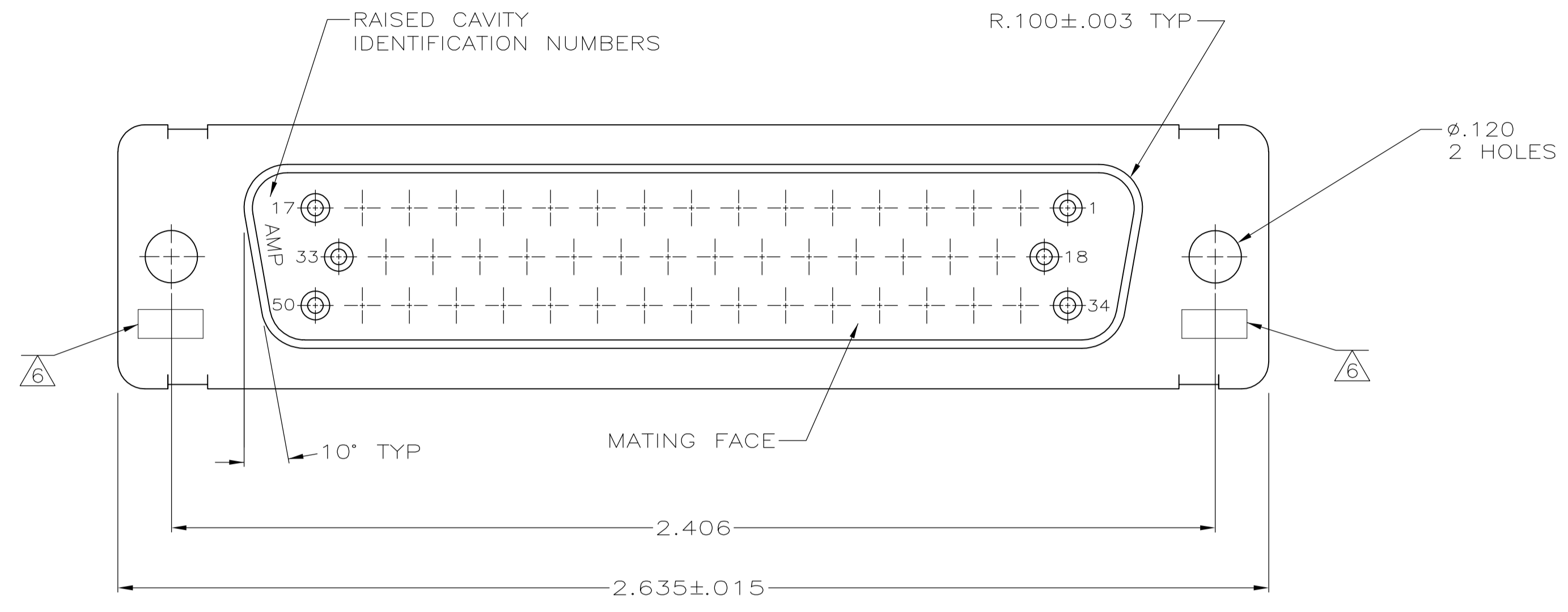

-	-	205169-4	-	⑧	STEEL PER ASTM-A-109	205169-4
SUPSD BY 206805-2	-	-	-	-	BRASS	205169-2
M24308/2-285F	M24308/2-5F	205563-2	⑦	⑦	STEEL PER ASTM-A-109	205169-1
MILITARY P/N ON PACKAGE	MILITARY P/N ON CONNECTOR	TYCO P/N ON CONNECTOR	REMARKS	SHELL FINISH	SHELL MAT'L	PART NO.

THIS DRAWING IS A CONTROLLED DOCUMENT.

DIMENSIONS: INCHES	TOLERANCES UNLESS OTHERWISE SPECIFIED:	DIN MANJUNATH G.M. 27-May-15	APVD CHARLES THOMAS 27-May-15	NAME CHARLES THOMAS	PRODUCT SPEC	SIZE A1	SCALE 4:1	SHEET 1 OF 1	REV R
0 PLC ± -	1 PLC ± -	2 PLC ± -	3 PLC ± .005	4 PLC ANGLES ± 0°30'	APPLICATION SPEC	WEIGHT	RESTRICTED TO		
MATERIAL SEE CALLOUTS	FINISH SEE CALLOUTS	00779	205169	AMPLIMITE RCPT FOR SOCKET CONTACTS HI-DENSITY HD-20 CONNECTOR SIZE 5 (50 POSN) SERIES 109					
CUSTOMER DRAWING		TE Connectivity							