

THIS DRAWING IS UNPUBLISHED

RELEASED FOR PUBLICATION

BY TYCO ELECTRONICS CORPORATION. ALL RIGHTS RESERVED

PART NUMBER	REV	TERMINATOR	FEED TYPE	DESCRIPTION
1530292-1	1	LEADMAKER	MECH POST FEED	CUTS CARRIER
1530292-2	1	BENCH	MECH PRE FEED	CUTS CARRIER
1530292-6	1	LEADMAKER	MECH POST FEED	CONTINUOUS CARRIER
7-1530292-1	1	LEADMAKER	MECH POST FEED	-1 AND SPARE PARTS
7-1530292-2	1	BENCH	MECH PRE FEED	-2 AND SPARE PARTS
7-1530292-6	1	LEADMAKER	MECH POST FEED	-6 AND SPARE PARTS
7-1530292-7	1	-	-	SPARE PARTS KIT

CRIMP DATA		PROVERTHA TERMINAL		TE CRIMP SPECS	
TERMINAL NAME: TERMINAL					
CRIMP	SIZE	TYPE	RANGE		
WIRE	1.17 [.046 IN]	F	24-28 AWG		
INSUL	1.22 [.048 IN]	F	0.81mm MAX [.032 IN MAX]		
WIRE STRIP LENGTH 2.5-3.0mm [.098-.118 IN]		APPL INSTRUCTIONS 408-8322 & 408-8490			
TERMINAL APPL SPEC		NONE	FEED		7.72 [1.304 IN]
TERMINALS APPLIED		M.F.R PN	TE PN		
-		C15246LG2T	2113093	-	
-		-	-	-	
-		-	-	-	
-		-	-	-	
-		-	-	-	
-		-	-	-	
WIRE SIZE	CRIMP HEIGHT	REF SETTING			
24 AWG	.76 ± 0.05 [.030 ± .002 IN]	C2			
26 AWG	.71 ± 0.05 [.028 ± .002 IN]	C5			
28 AWG	.69 ± 0.05 [.027 ± .002 IN]	C6			
-	-	-		-	
-	-	-		-	
-	-	-		-	
-	-	-		-	
-	-	-		-	
-	-	-		-	

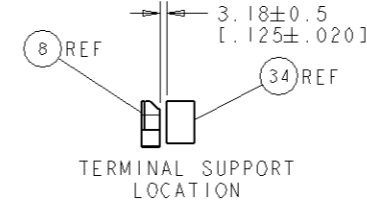
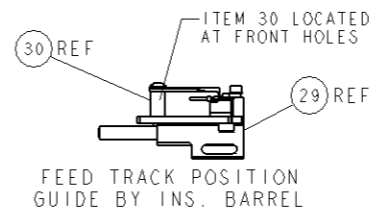
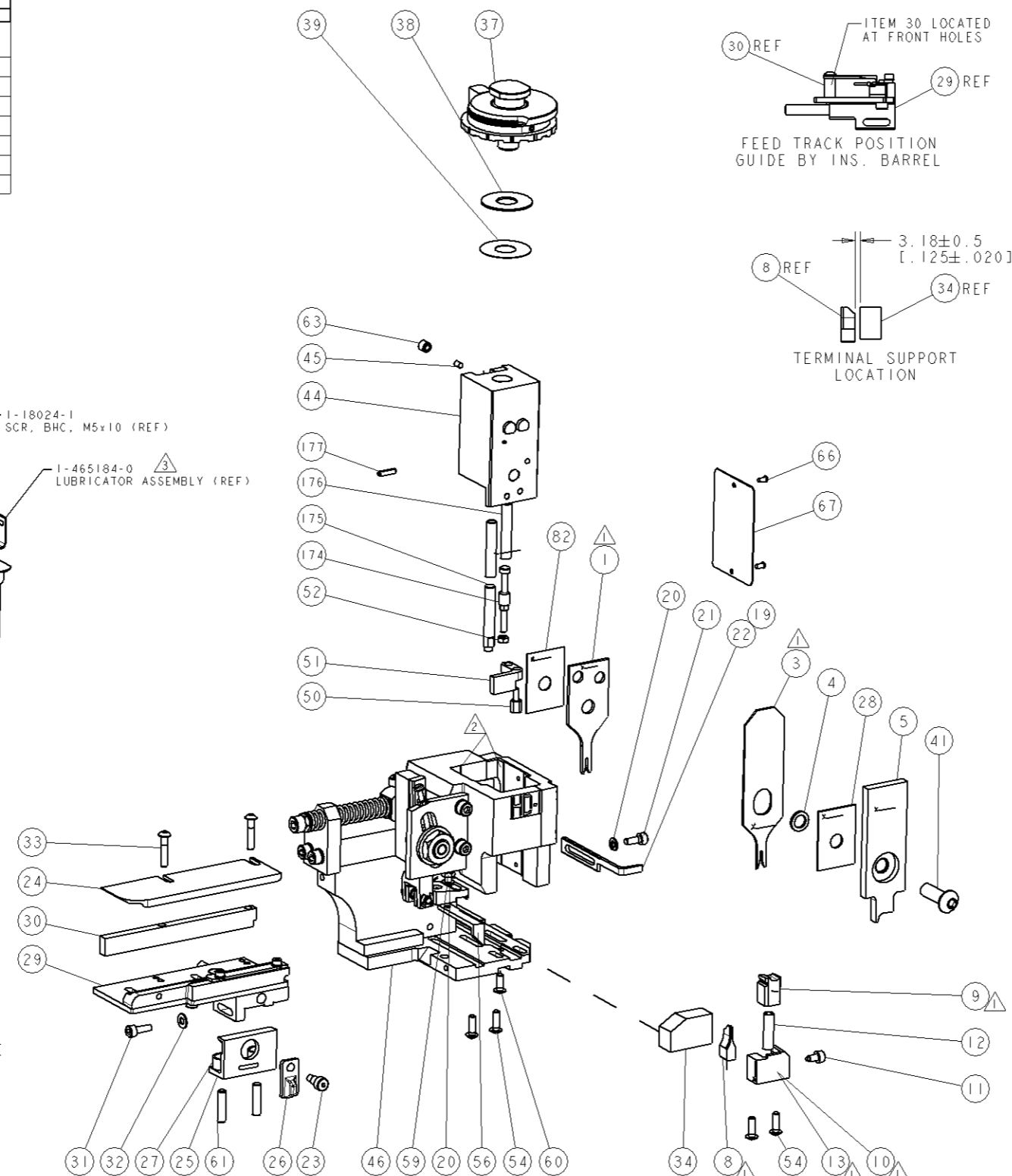
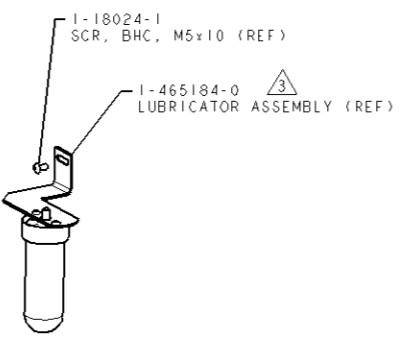

- ▲ RECOMMENDED SPARE PARTS.
- ▲ GREASE RAM, CAM, CAM FOLLOWER AND FEED ROD LIGHTLY.
- ▲ CERTAIN TERMINALS REQUIRE LUBRICATION. REFER TO THE APPLICATOR INSTRUCTION SHEET FOR MORE INFORMATION.
- 4. LUBRICATE DAILY PER THE APPLICATOR INSTRUCTION SHEET SUPPLIED WITH THE APPLICATOR.

* WARNING
ON INSTALLATION, SET WIRE DISC TO LARGEST WIRE SIZE SETTING. USE OF SETTINGS BELOW MIN. REQUIRED CRIMP HEIGHT SETTING WILL CAUSE DAMAGE TO CRIMP TOOLING.

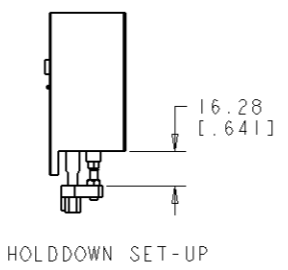
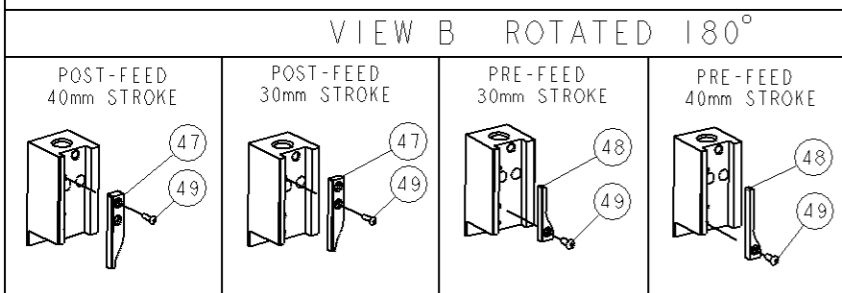

PROTOTYPE DESIGN NOT RELEASED FOR PRODUCTION

LOC A DIST 66

SET UP GAGE 458637-3

REVISIONS					
REV	DATE	BY	APPV	DESCRIPTION	
1	02MAR2010	L.Z	N.D	DEVELOPMENT	

REV	DATE	BY	APPV	DESCRIPTION	ITEM NO			
-	1	1	1	1	1	993111-8	PIN, SLOTTED SPRING 3.0 X 12.0	177
-	2	2	2	2	2	3-22280-7	SPRING, COMPRESSION	176
-	1	1	1	1	1	1752353-1	GUIDE PIN, HOLDDOWN	175
-	1	1	1	1	1	1901680-1	GUIDE PIN, HOLDDOWN	174
-	1	1	1	1	1	455888-5	SPACER, CRIMPER	82
-	1	1	1	1	1	1338705-3	DOCUMENTATION PACKAGE	71
-	1	1	1	1	1	461264-5	PLATE, IDENTIFICATION	67
-	2	2	2	2	2	21017-2	SCREW, DRIVE	66
-	1	1	1	1	1	3-18031-0	SCR, SET, CUP POINT M6 X 6.0	63
-	2	2	2	2	2	2-18032-5	SCR, SET, FLT POINT M5 X 20.0	61
-	1	1	1	1	1	18024-7	SCR, BTN SKT HD CAP (M4 X 10.0)	60
-	1	1	1	1	1	5-18022-2	SCR, HEX HD CAP M4 X 8.0	59
-	1	1	1	1	1	1338685-1	PAWL, FEED	56
-	4	4	4	4	4	18024-8	SCR, BTN SKT HD CAP (M4 X 12.0)	54
-	1	1	1	1	1	1-18030-0	NUT, HEX, REG M3.5	52
-	1	1	1	1	1	1901681-1	HOLDDOWN, TERMINAL	51
-	1	1	1	1	1	1-1752354-3	STANDOFF, HOLD-DOWN	50
-	1	1	1	1	1	18024-3	SCR, BTN SKT HD CAP (M3 X 10.0)	49
-	1	1	1	1	1	1338675-1	CAM, UNIVERSAL PRE FEED	48
-	1	1	1	1	1	1338676-1	CAM, UNIVERSAL POST-FEED	47
-	1	1	1	1	1	1320999-3	APPLICATOR SUBASSEMBLY, HDI	46
-	1	1	1	1	1	690191-1	PLUG, NYLON	45
-	1	1	1	1	1	1633724-5	RAM, (SIDE FEED)	44
-	1	1	1	1	1	2-18024-6	SCR, BTN SKT HD CAP (M8 X 25.0)	41
-	1	1	1	1	1	690125-1	SHIM SUB-ASSY	39
-	1	1	1	1	1	469367-7	SHIM	38
-	1	1	1	1	1	879103-3	FINE ADJUST HEAD ASSEMBLY	37
-	1	1	1	1	1	1752356-3	SUPPORT, TERMINAL	34
-	2	2	2	2	2	1-18024-0	SCR, BTN SKT HD CAP (M4 X 20.0)	33
-	1	1	1	1	1	18027-2	WASHER, FLAT, REG M4	32
-	1	1	1	1	1	1-18023-2	SCR, SKT HD CAP M4 X 12.0	31
-	1	1	1	1	1	1320908-9	SPACER, STRIP GUIDE	30
-	1	1	1	1	1	1633073-3	STRIP GUIDE ASSEMBLY	29
-	1	1	1	1	1	455888-8	SPACER, CRIMPER	28
-	2	2	2	2	2	1-22284-0	SPRING, COMPRESSION	27
-	1	1	1	1	1	356835-1	LEVER, DRAG RELEASE	26
-	1	1	1	1	1	240792-1	DRAG, TERMINAL	25
-	1	1	1	1	1	1320928-1	PLATE, STRIP GUIDE	24
-	1	1	1	1	1	980371-4	SCR, SKT HD SHLDR 5.0 DIA X 6.0	23
-	1	1	1	1	1	690472-2	STRIPPER	22
-	1	1	1	1	1	1-18023-1	SCR, SKT HD CAP M4 X 10.0	21
-	2	2	2	2	2	18025-2	WASHER, SPRG LOCK, REG M4	20
-	1	1	1	1	1	690472-1	STRIPPER	19
-	1	1	1	1	1	1338684-2	SHEAR HOLDER, FRONT	13
-	1	1	1	1	1	3-22280-3	SPRING, COMPRESSION	12
-	1	1	1	1	1	356885-5	STOP, SHEAR	11
-	1	1	1	1	1	1-1320921-0	SHEAR HOLDER, FRONT, CUT	10
-	1	1	1	1	1	462006-6	FLOATING SHEAR, FRONT	9
-	1	2	2	2	2	2-1633620-6	ANVIL, COMBINATION	8
-	-	-	-	-	-	-	-	7
-	-	-	-	-	-	-	-	6
-	1	1	1	1	1	2-455889-0	DEPRESSOR, SHEAR	5
-	1	1	1	1	1	2-238011-3	BLOCK, CRIMPER SPACER	4
-	1	2	2	2	2	6-1633511-4	CRIMPER, INSULATION F	3
-	-	-	-	-	-	-	-	2
-	1	2	2	2	2	2-568176-4	CRIMPER, WIRE	1

REV	DATE	BY	APPV	DESCRIPTION	ITEM NO				
-77	-76	-72	-71	-6	-2	-1	PART NO	DESCRIPTION	ITEM NO

TYCO ELECTRONICS CORPORATION

TYCO ELECTRONICS

Harrisburg, PA 17105-3606

NAME: FINE ADJUST SIDE FEED HDI APPLICATOR

SIZE: A | CASE CODE: 00779 | DRAWING NO: 1530292

RESTRICTED TO: CUSTOMER ACCESSIBLE PRODUCTION DRAWING

SCALE: 3:5

SHEET: 1