

DESCRIPTION

The IF-E99B is a very high-speed red LED housed in a “connector-less” style plastic fiber optic package. The output spectrum of the IF-E99B is produced by a GaAlAs die that peaks at a wavelength of 650 nm, one of the optimal transmission windows of PMMA plastic optical fiber. The device package features an internal micro-lens, and a precision-molded PBT housing to ensure efficient optical coupling with standard 1000 μm core plastic fiber cable.

APPLICATION HIGHLIGHTS

The fast transition times of the IF-E99B make it suitable for high-speed digital data links. Link distances in excess of 75 meters at data rates of 156 Mbps are possible using standard 1000 μm core plastic fiber and an IF-D98 photologic detector. The wide analog bandwidth permits direct modulation at RF frequencies exceeding 70MHz. Drive circuit design for the IF-E99B requires good RF and digital design techniques, but is much simpler than required for laser diodes, making it a good low-cost solution in a variety of high frequency POF analog and digital applications.

APPLICATIONS

- PC-to-Peripheral Data Links
- Motor Controller Triggering
- Ethernet LANs
- Medical Instruments
- Automotive Electronics
- Digitized Video and HDTV
- Sonet/SDH Transmitters
- Robotics Communications
- Isolation from Lightning and Voltage Transients

FEATURES

- ◆ No Optical Design Required
- ◆ Mates with Standard 1000 μm Core, 2.2 mm Jacketed Plastic Fiber Cable
- ◆ Mates with 2.2 mm Jacketed Multimode Glass Fiber, 200/230 or 400/430 using Active Device Adapter – 51 0537; 51 0538
- ◆ Internal Micro-lens for Efficient Coupling
- ◆ Inexpensive Plastic Connector Housing
- ◆ Connector-Less Fiber Termination and Insertion
- ◆ Interference-Free Transmission from Light-Tight Housing
- ◆ Excellent Linearity
- ◆ Visible Light Output
- ◆ RoHS compliant

MAXIMUM RATINGS

(T_A =25°C)
 Operating Temperature Range (T_{OP}).....-0° to 60°C
 Storage Temperature Range (T_{STG}).....-40° to 85°C
 Junction Temperature (T_J).....75°C
 Soldering Temperature (2mm from case bottom) (T_S) t ≤ 5 s.....240°C
 Reverse Voltage (V_R).....3 V
 Power Dissipation (P_{TOT}) T_A =25°C.....130 mW
 De-rate Above 25°C.....1.7 mW/°C
 Forward Current, DC (I_F).....50 mA
 De-rate Above 25°C.....0.57 mA/°C

CHARACTERISTICS (T_A =25°C)

Parameter	Symbol	Min.	Typ.	Max.	Unit
Peak Wavelength	λ _{PEAK}	640	650	660	nm
Spectral Bandwidth (FWHM)	Δλ	–	10	–	nm
Output Power Coupled into Plastic Fiber (1 mm core diameter). Lens to Fiber distance ≤ .1 mm, 1m SH4001 fiber, I _F =per circuit (50% Duty Cycle) I _F =20 mA DC	P _O	355 -4.5	630 -2.0	1120 +0.5	μW dBm
Output Power Coupled into Glass Fiber (200/230 μm core) Distance Lens to Fiber ≤0.1 mm, 1 meter BC04265-10 fiber, I _F =20 mA DC	P _O	–	61.6 -12.14	–	μW dBm
Switching Times (10% to 90% and 90% to 10%) (R _L =47Ω, I _F =10 mA)	t _r , t _f	–	3	–	ns
Capacitance (V _F =0, F=1 MHz)	C ₀	–	6.5	–	pF
Forward Voltage (I _F =30 mA)	V _F	–	1.9	2.4	V
Cut off frequency	f _c	60	70	–	MHz

CAUTION: The IF E99B is Class 1B ESD sensitive per testing using the HBM: 1.5k Ohm; 100 pF; +/- 1000V. To minimize risk of damage observe appropriate precautions during handling and processing.

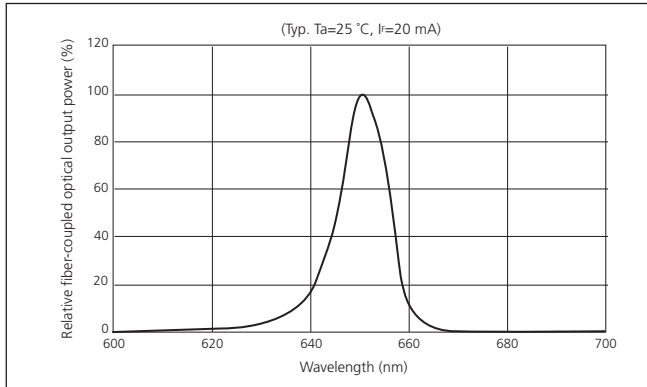

FIGURE 1. Relative intensity versus wavelength.

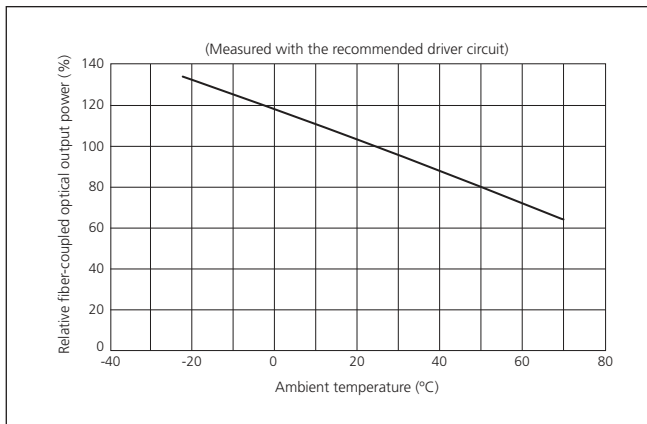

FIGURE 2. Optical power output versus temperature (If=20mA)

APPLICATION NOTES

The application circuit given in Figure 3 can be used to drive the IF-E99B for fast applications. Gate U1 represents the circuit being used to drive the IF-E99B. This must be able to supply the desired drive current at the output voltage. Resistor R_A supplies most of the drive current for the IF-E99B. The amount of current supplied is $I_A = (V_{U1} - V_f) / R_A$, where V_f is the IF-E99B forward voltage and V_{U1} is the drive circuits output voltage under load. Resistor R_B speeds up the switching time by keeping the voltage across the IF-E99B from going to zero during turn off. It also supplies some of the drive current. The drive current from R_B is $I_B = (V_{CC} - V_f) / R_B$, where V_{CC} is the supply voltage. The total drive current to the IF-E99B is $I_A + I_B$. Some power is wasted in R_B when the IF-E99B is off. Capacitor C_A is used to increase the drive current during switching and speed up the turn on and turn off times. It must not be so large as to overdrive the IF-E99B during turn on or drive the voltage negative during turn off. For lower speed applications, only R_A is needed and C_A and R_B can be omitted.

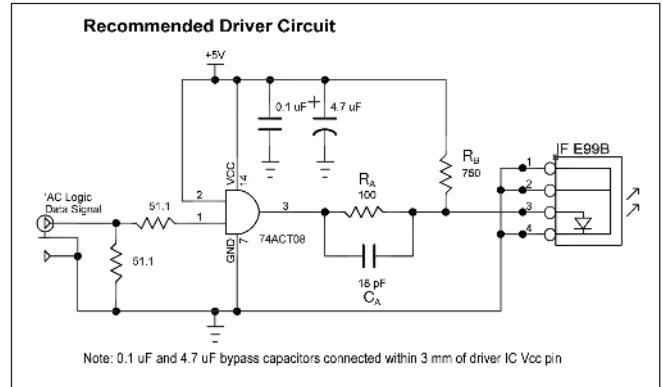

FIGURE 3. Typical interface circuit. (If = 35mA).

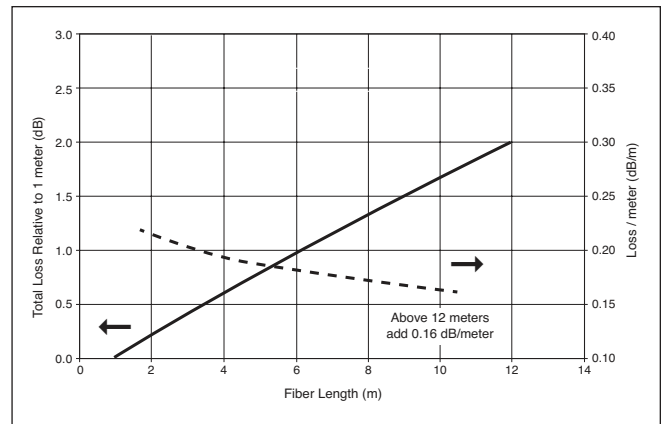

FIGURE 4. Fiber Loss in GH4001

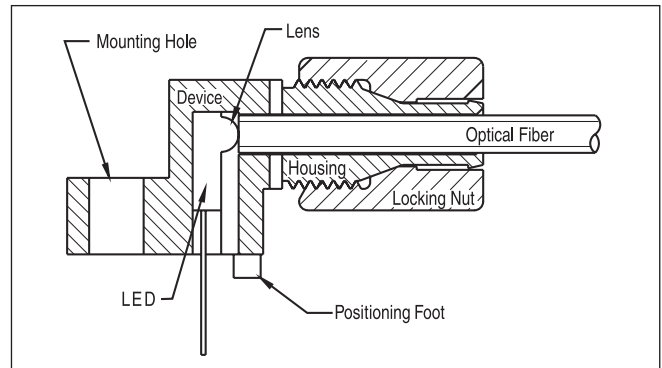

FIGURE 5. Cross-section of fiber optic device.

FIBER TERMINATION INSTRUCTIONS – PLASTIC OPTICAL FIBER

1. Cut off the ends of the optical fiber with a single-edge razor blade or sharp knife. Try to obtain a precise 90-degree angle (square).
2. Insert the fiber through the locking nut and into the connector until the core tip seats against the internal micro-lens.
3. Screw the connector locking nut down to a snug fit, locking the fiber in place. Do not exceed a torque of 0.4 N·m.

Glass fiber – Refer to instructions listed on manufacturer's data sheet for each active device adapter.

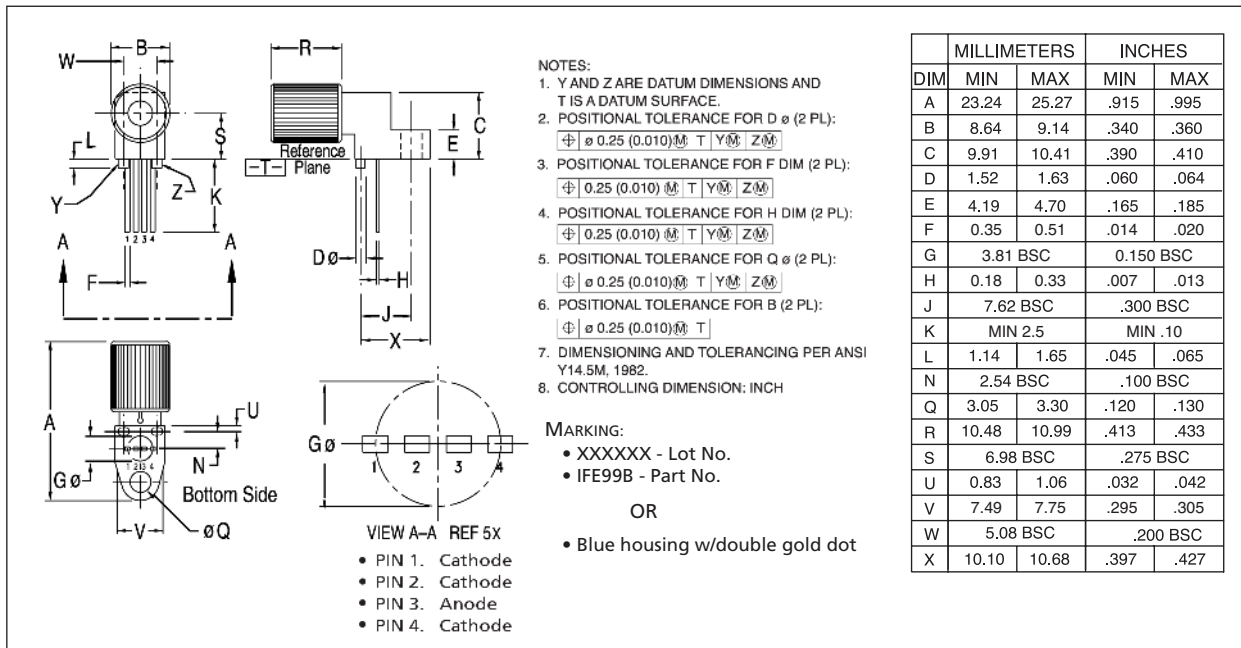

FIGURE 6. Case outline. Specifications are believed to be accurate but are subject to change. Industrial Fiber Optics assumes no responsibility for the consequences of using the information provided beyond replacement warranty for products not meeting stated specifications. Industrial Fiber Optics products are not authorized for use in life support applications without written approval from the President of Industrial Fiber Optics Corporation.

CAUTION:

- To avoid degraded device life due to package stress, do not bend or form leads outside the orientation shown on drawing.
- Ensure that solder flux does not migrate into the device and block the optical path, degrading the performance.
- If washing the device, liquid may become trapped in the part cavity. Ensure that all potentially corrosive materials are flushed out of the device.