

200 MHz Spread Spectrum Clock Synthesizer/Driver with Differential CPU Outputs

Features

- Compliant with Intel® CK-Titan Clock Synthesizer/Driver Specifications
- Multiple output clocks at different frequencies
- Three pairs of differential CPU outputs, up to 200 MHz
- Ten synchronous PCI clocks, three free-running
- Six 3V66 clocks
- Two 48 MHz clocks
- One reference clock at 14.318 MHz
- One VCH clock
- Spread Spectrum clocking (down spread)
- Power-down features (PCI_STOP#, CPU_STOP#, PWR_DWN#)
- Three Select inputs (Mode select & IC Frequency Select)
- OE and Test Mode support
- 56-pin SSOP package and 56-pin TSSOP package

Benefits

- Supports next-generation Pentium® processors using differential clock drivers
- Motherboard clock generator
- Support Multiple CPUs and a chipset
- Support for PCI slots and chipset
- Supports AGP, DRCG reference and Hub Link
- Supports USB host controller and graphic controller
- Supports ISA slots and I/O chip
- Enables reduction of electromagnetic interference (EMI) and overall system cost
- Enables ACPI-compliant designs
- Supports up to four CPU clock frequencies
- Enables ATE and “bed of nails” testing
- Widely available, standard package enables lower cost

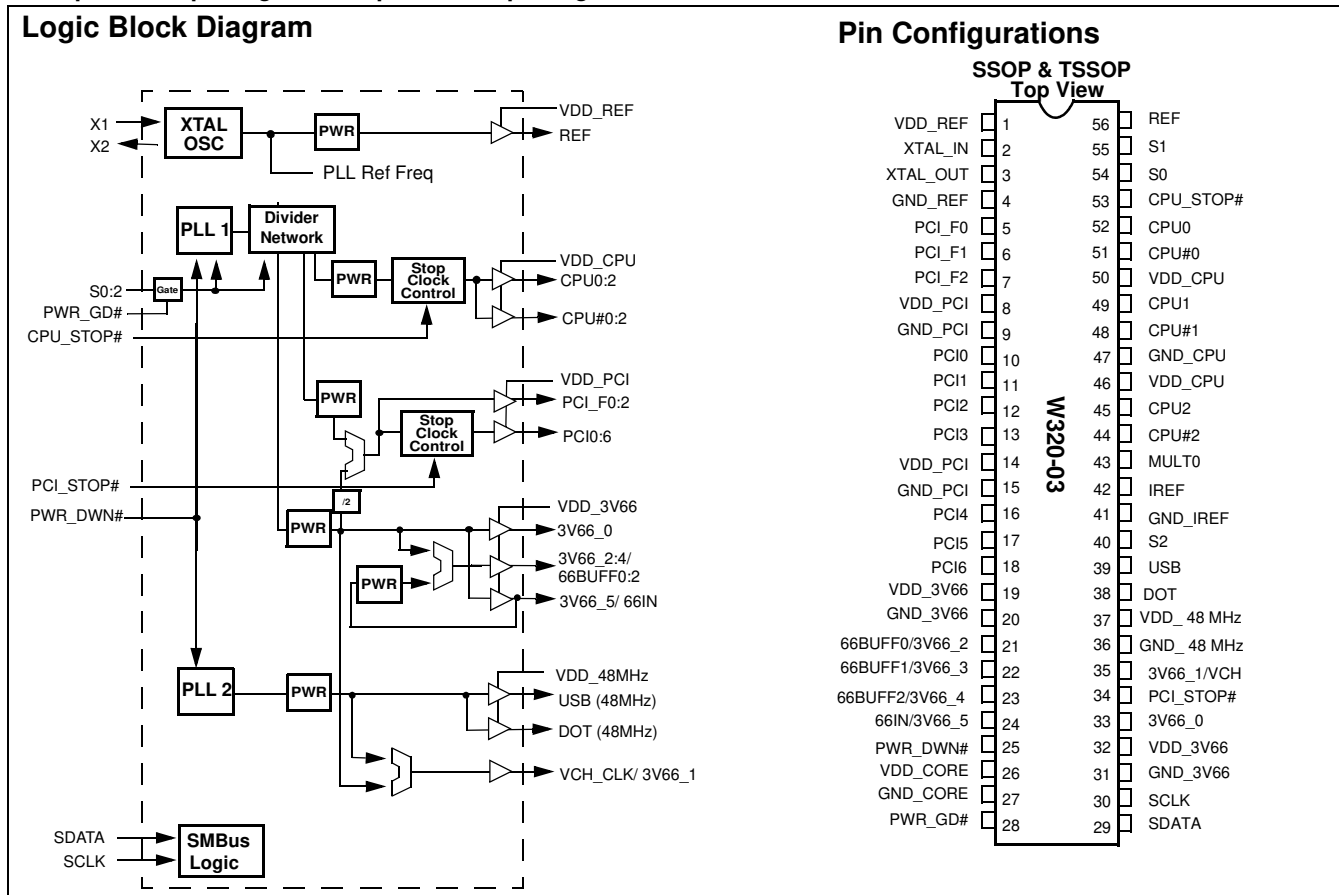



Pin Summary

Name	Pins	Description
REF	56	3.3V 14.318 MHz clock output
XTAL_IN	2	14.318 MHz crystal input
XTAL_OUT	3	14.318 MHz crystal input
CPU, CPU# [0:2]	44, 45, 48, 49, 51, 52	Differential CPU clock outputs
3V66_0	33	3.3V 66 MHz clock output
3V66_1/VCH	35	3.3V selectable through SMBus to be 66 MHz or 48 MHz
66IN/3V66_5	24	66 MHz input to buffered 66BUFF and PCI or 66 MHz clock from internal VCO
66BUFF [2:0] /3V66 [4:2]	21, 22, 23	66 MHz buffered outputs from 66Input or 66 MHz clocks from internal VCO
PCI_F [0:2]	5, 6, 7,	33 MHz clocks divided down from 66Input or divided down from 3V66
PCI [0:6]	10, 11, 12, 13, 16, 17, 18	PCI clock outputs divided down from 66Input or divided down from 3V66
USB	39	Fixed 48 MHz clock output
DOT	38	Fixed 48 MHz clock output
S2	40	Special 3.3V 3 level input for Mode selection
S1, S0	54, 55	3.3V LVTTTL inputs for CPU frequency selection
IREF	42	A precision resistor is attached to this pin which is connected to the internal current reference
MULT0	43	3.3V LVTTTL input for selecting the current multiplier for the CPU outputs
PWR_DWN#	25	3.3V LVTTTL input for Power_Down# (active LOW)
PCI_STOP#	34	3.3V LVTTTL input for PCI_STOP# (active LOW)
CPU_STOP#	53	3.3V LVTTTL input for CPU_STOP# (active LOW)
PWRGD#	28	3.3V LVTTTL input is a level sensitive strobe used to determine when S[2:0] and MULTIO inputs are valid and OK to be sampled (Active LOW). Once PWRGD# is sampled LOW, the status of this output will be ignored.
SDATA	29	SMBus compatible SDATA
SCLK	30	SMBus compatible Sclk
VDD_REF, VDD_PCI, VDD_3V66, VDD_CPU	1, 8, 14, 19, 32, 46, 50	3.3V power supply for outputs
VDD_48 MHz	37	3.3V power supply for 48 MHz
VDD_CORE	26	3.3V power supply for PLL
GND_REF, GND_PCI, GND_3V66, GND_IREF, VDD_CPU	4, 9, 15, 20, 31, 36, 41, 47	Ground for outputs
GND_CORE	27	Ground for PLL

Function Table [1]

S2	S1	S0	CPU (MHz)	3V66[0:1] (MHz)	66BUFF[0:2]/3V66[2:4] (MHz)	66IN/3V66_5 (MHz)	PCI_F/PCI (MHz)	REF0(MHz)	USB/DOT (MHz)	Notes
1	0	0	66 MHz	66 MHz	66 IN	66 MHz Input	66 IN/2	14.318 MHz	48 MHz	2, 3, 4
1	0	1	100 MHz	66 MHz	66 IN	66 MHz Input	66 IN/2	14.318 MHz	48 MHz	2, 3, 4
1	1	0	200 MHz	66 MHz	66 IN	66 MHz Input	66 IN/2	14.318 MHz	48 MHz	2, 3, 4
1	1	1	133 MHz	66 MHz	66 IN	66 MHz Input	66 IN/2	14.318 MHz	48 MHz	2, 3, 4
0	0	0	66 MHz	66 MHz	66 MHz	66 MHz	33 MHz	14.318 MHz	48 MHz	2, 3, 4
0	0	1	100 MHz	66 MHz	66 MHz	66 MHz	33 MHz	14.318 MHz	48 MHz	2, 3, 4
0	1	0	200 MHz	66 MHz	66 MHz	66 MHz	33 MHz	14.318 MHz	48 MHz	2, 3, 4
0	1	1	133 MHz	66 MHz	66 MHz	66 MHz	33 MHz	14.318 MHz	48 MHz	2, 3, 4
Mid	0	0	Hi-Z	Hi-Z	Hi-Z	Hi-Z	Hi-Z	Hi-Z	Hi-Z	1, 5
Mid	0	1	TCLK/2	TCLK/4	TCLK/4	TCLK/4	TCLK/8	TCLK	TCLK/2	6, 7, 8
Mid	1	0	Reserved	Reserved	Reserved	Reserved	Reserved	Reserved	Reserved	-
Mid	1	1	Reserved	Reserved	Reserved	Reserved	Reserved	Reserved	Reserved	-

Swing Select Functions

Mult0	Board Target Trace/Term Z	Reference R, IREF = V _{DD} /(3*Rr)	Output Current	V _{OH} @ Z
0	60Ω	Rr = 221 1%, IREF = 5.00 mA	I _{OH} = 4*IREF	1.0V @ 50
1	50Ω	Rr = 475 1%, IREF = 2.32 mA	I _{OH} = 6*IREF	0.7V @ 50

Clock Driver Impedances

Buffer Name	V _{DD} Range	Buffer Type	Impedance		
			Minimum Ω	Typical Ω	Maximum Ω
CPU, CPU#		Type X1		50	
REF	3.135–3.465	Type 3	20	40	60
PCI, 3V66, 66BUFF	3.135–3.465	Type 5	12	30	55
USB	3.135–3.465	Type 3A	12	30	55
DOT	3.135–3.465	Type 3B	12	30	55

Clock Enable Configuration

PWR_DWN#	CPU_STOP#	PCI_STOP#	CPU	CPU#	3V66	66BUFF	PCI_F	PCI	USB/DOT	VCOS/OSC
0	X	X	IREF*2	FLOAT	LOW	LOW	LOW	LOW	LOW	OFF
1	0	0	IREF*2	FLOAT	ON	ON	ON	OFF	ON	ON
1	0	1	IREF*2	FLOAT	ON	ON	ON	ON	ON	ON
1	1	0	ON	ON	ON	ON	ON	OFF	ON	ON
1	1	1	ON	ON	ON	ON	ON	ON	ON	ON

Notes:

1. TCLK is a test clock driven in on the XTALIN input in test mode.
2. "Normal" mode of operation.
3. Range of reference frequency allowed is min. = 14.316 nominal = 14.31818 MHz, max = 14.32 MHz.
4. Frequency accuracy of 48 MHz must be +167PPM to match USB default.
5. Mid is defined a Voltage level between 1.0V and 1.8V for 3 level input functionality. Low is below 0.8V. High is above 2.0V.
6. TCLK is a test clock over driven on the XTAL_IN input during test mode.
7. Required for DC output impedance verification.
8. These modes are to use the SAME internal dividers as the CPU = 200-MHz mode. The only change is to slow down the internal VCO to allow under clock margining.

Serial Data Interface (SMBus)

To enhance the flexibility and function of the clock synthesizer, a two signal SMBus interface is provided according to the SMBus specification. Through the Serial Data Interface (SDI), various device functions such as individual clock output buffers, etc can be individually enabled or disabled. W320-03 support both block read and block write operations.

The registers associated with the SDI initialize to their default setting upon power-up, and therefore use of this interface is optional. Clock device register changes are normally made upon system initialization, if any are required. The interface can also be used during system operation for power management functions.

Data Protocol

The clock driver serial protocol accepts only block writes from the controller. The bytes must be accessed in sequential order from lowest to highest byte, (most significant bit first) with the

ability to stop after any complete byte has been transferred. Indexed bytes are not allowed.

A block write begins with a slave address and a WRITE condition. The R/W bit is used by the SMBus controller as a data direction bit. A zero indicates a WRITE condition to the clock device. The slave receiver address is 11010010 (D2h).

A command code of 0000 0000 (00h) and the byte count bytes are required for any transfer. After the command code, the core logic issues a byte count which describes number of additional bytes required for the transfer, not including the command code and byte count bytes. For example, if the host has 20 data bytes to send, the first byte would be the number 20 (14h), followed by the 20 bytes of data. The byte count byte is required to be a minimum of one byte and a maximum of 32 bytes It may not be 0. *Figure 1* shows an example of a block write.

A transfer is considered valid after the acknowledge bit corresponding to the byte count is read by the controller.

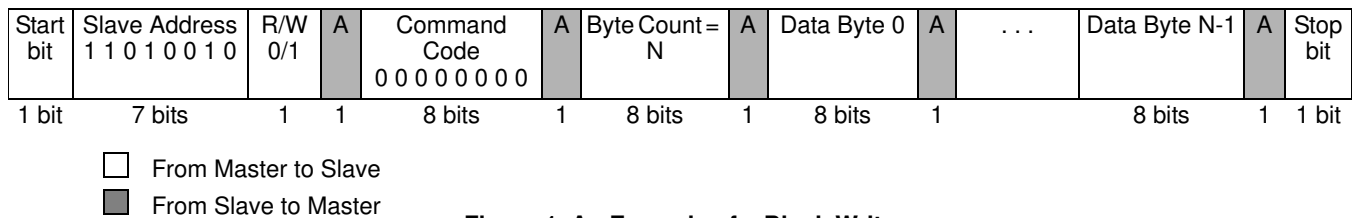

Figure 1. An Example of a Block Write

Data Byte Configuration Map

Data Byte 0: Control Register (0 = Enable, 1 = Disable)

Bit	Affected Pin#	Name	Description	Type	Power On Default
Bit 7	5, 6, 7, 10, 11, 12, 13, 16, 17, 18, 33, 35	PCI [0:6] CPU[2:0] 3V66[1:0]	Spread Spectrum Enable 0 = Spread Off, 1 = Spread On	R/W	0
Bit 6	–	TBD	TBD	R	0
Bit 5	35	3V66_1/VCH	VCH Select 66 MHz/48 MHz 0 = 66 MHz, 1 = 48 MHz	R/W	0
Bit 4	44, 45, 48, 49, 51, 52	CPU [2:0] CPU# [2:0]	CPU_STOP# Reflects the current value of the external CPU_STOP# pin	R	N/A
Bit 3	10, 11, 12, 13, 16, 17, 18	PCI [6:0]	PCI_STOP# (Does not affect PCI_F [2:0] pins)	R/W	N/A
Bit 2	–	–	S2 Reflects the value of the S2 pin sampled on Power-up	R	N/A
Bit 1	–	–	S1 Reflects the value of the S1 pin sampled on Power-up	R	N/A
Bit 0	–	–	S0 Reflects the value of the S1 pin sampled on Power-up	R	N/A

Data Byte 1

Bit	Pin#	Name	Description	Type	Power On Default
Bit 7	–	N/A	CPU Mult0 Value	R	N/A
Bit 6	–	N/A	TBD	R	0
Bit 5	44, 45	CPU2 CPU2#	Allow Control of CPU2 with assertion of CPU_STOP# 0 = Not free running; 1 = Free running	R/W	0
Bit 4	48, 49	CPU1 CPU1#	Allow Control of CPU1 with assertion of CPU_STOP# 0 = Not free running; 1 = Free running	R/W	0
Bit 3	51, 52	CPU0 CPU0#	Allow Control of CPU0 with assertion of CPU_STOP# 0 = Not free running; 1 = Free running	R/W	0
Bit 2	44, 45	CPU2 CPU2#	CPU2 Output Enable 1 = Enabled; 0 = Disabled	R/W	1
Bit 1	48, 49	CPU1 CPU1#	CPU1 Output Enable 1 = Enabled; 0 = Disabled	R/W	1
Bit 0	51, 52	CPU0 CPU0#	CPU0 Output Enable 1 = Enabled; 0 = Disabled	R/W	1

Data Byte 2

Bit	Pin#	Name	Pin Description	Type	Power On Default
Bit 7	–	N/A	N/A	R	0
Bit 6	18	PCI6	PCI6 Output Enable 1 = Enabled; 0 = Disabled	R/W	1
Bit 5	17	PCI5	PCI5 Output Enable 1 = Enabled; 0 = Disabled	R/W	1
Bit 4	16	PCI4	PCI4 Output Enable 1 = Enabled; 0 = Disabled	R/W	1
Bit 3	13	PCI3	PCI3 Output Enable 1 = Enabled; 0 = Disabled	R/W	1
Bit 2	12	PCI2	PCI2 Output Enable 1 = Enabled; 0 = Disabled	R/W	1
Bit 1	11	PCI1	PCI1 Output Enable 1 = Enabled; 0 = Disabled	R/W	1
Bit 0	10	PCI0	PCI0 Output Enable 1 = Enabled; 0 = Disabled	R/W	1

Data Byte 3

Bit	Pin#	Name	Pin Description	Type	Power On Default
Bit 7	38	DOT	DOT 48-MHz Output Enable	R/W	1
Bit 6	39	USB	USB 48-MHz Output Enable	R/W	1
Bit 5	7	PCI_F2	Allow control of PCI_F2 with assertion of PCI_STOP# 0 = Free running; 1 = Stopped with PCI_STOP#	R/W	0
Bit 4	6	PCI_F1	Allow control of PCI_F1 with assertion of PCI_STOP# 0 = Free running; 1 = Stopped with PCI_STOP#	R/W	0
Bit 3	5	PCI_F0	Allow control of PCI_F0 with assertion of PCI_STOP# 0 = Free running; 1 = Stopped with PCI_STOP#	R/W	0
Bit 2	7	PCI_F2	PCI_F2 Output Enable	R/W	1
Bit 1	6	PCI_F1	PCI_F1 Output Enable	R/W	1
Bit 0	5	PCI_F0	PCI_F0 Output Enable	R/W	1

Data Byte 4

Bit	Pin#	Name	Pin Description	Type	Power On Default
Bit 7	--	TBD	N/A	R	0
Bit 6	--	TBD	N/A	R	0
Bit 5	33	3V66_0	3V66_0 Output Enable 1 = Enabled; 0 = Disabled	R/W	1
Bit 4	35	3V66_1/VCH	3V66_1/VCH Output Enable 1 = Enabled; 0 = Disabled	R/W	1
Bit 3	24	66IN/3V66_5	3V66_5 Output Enable 1 = Enable; 0 = Disable NOTE: THIS BIT SHOULD BE USED WHEN PIN 24 IS CONFIGURED AS 3V66_5 OUTPUT. DO NOT CLEAR THIS BIT WHEN PIN 24 IS CONFIGURED AS 66IN INPUT.	R/W	1
Bit 2	23	66BUFF2	66-MHz Buffered 2 Output Enable 1 = Enabled; 0 = Disabled	R/W	1
Bit 1	22	66BUFF1	66-MHz Buffered 1 Output Enable 1 = Enabled; 0 = Disabled	R/W	1
Bit 0	21	66BUFF0	66-MHz Buffered 0 Output Enable 1 = Enabled; 0 = Disabled	R/W	1

Data Byte 5

Bit	Pin#	Name	Pin Description	Type	Power On Default
Bit 7		N/A	N/A	R	0
Bit 6		N/A	N/A	R	0
Bit 5		66BUFF [2:0]	Tpd 66IN to 66BUFF propagation delay control	R/W	0
Bit 4		66BUFF [2:0]		R/W	0
Bit 3		DOT	DOT edge rate control	R/W	0
Bit 2		DOT		R/W	0
Bit 1		USB	USB edge rate control	R/W	0
Bit 0		USB		R/W	0

Byte 6: Vendor ID

Bit	Description	Type	Power On Default
Bit 7	Revision Code Bit 3	R	0
Bit 6	Revision Code Bit 2	R	0
Bit 5	Revision Code Bit 1	R	0
Bit 4	Revision Code Bit 0	R	1
Bit 3	Vendor ID Bit 3	R	0
Bit 2	Vendor ID Bit 2	R	1
Bit 1	Vendor ID Bit 1	R	0
Bit 0	Vendor ID Bit 0	R	0

Maximum Ratings

(Above which the useful life may be impaired. For user guidelines, not tested.)

Supply Voltage.....-0.5 to +7.0V
 Input Voltage.....-0.5V to $V_{DD}+0.5$

Storage Temperature
 (Non-condensing).....-65°C to +150°C
 Max. Soldering Temperature (10 sec)..... +260°C
 Junction Temperature..... +150°C
 Package Power Dissipation..... 1W
 Static Discharge Voltage
 (per MIL-STD-883, Method 3015) > 2000V

Operating Conditions Over which Electrical Parameters are Guaranteed^[9]

Parameter	Description	Min.	Max.	Unit
$V_{DD_REF}, V_{DD_PCI}, V_{DD_CORE}, V_{DD_3V66}, V_{DD_CPU}$	3.3V Supply Voltages	3.135	3.465	V
$V_{DD_48\text{ MHz}}$	48-MHz Supply Voltage	2.85	3.465	V
T_A	Operating Temperature, Ambient	0	70	°C
C_{in}	Input Pin Capacitance		5	pF
C_{XTAL}	XTAL Pin Capacitance		22.5	pF
C_L	Max. Capacitive Load on USBCLK, REF, PCICLK, 3V66		20 30	pF
$f_{(REF)}$	Reference Frequency, Oscillator Nominal Value	14.318	14.318	MHz

Electrical Characteristics Over the Operating Range

Parameter	Description	Test Conditions	Min.	Max.	Unit
V_{IH}	High-level Input Voltage	Except Crystal Pads. Threshold voltage for crystal pads = $V_{DD}/2$	2.0		V
V_{IL}	Low-level Input Voltage	Except Crystal Pads		0.8	V
V_{OH}	High-level Output Voltage	USB, REF, 3V66	$I_{OH} = -1\text{ mA}$	2.4	V
		PCI	$I_{OH} = -1\text{ mA}$	2.4	V
V_{OL}	Low-level Output Voltage	USB, REF, 3V66	$I_{OL} = 1\text{ mA}$	0.4	V
		PCI	$I_{OL} = 1\text{ mA}$	0.55	V
I_{IH}	Input High Current	$0 \leq V_{IN} \leq V_{DD}$	-5	5	mA
I_{IL}	Input Low Current	$0 \leq V_{IN} \leq V_{DD}$	-5	5	mA
I_{OH}	High-level Output Current	CPU For $I_{OH} = 6 \cdot I_{Ref}$ Configuration	Type X1, $V_{OH} = 0.65V$	12.9	mA
			Type X1, $V_{OH} = 0.74V$	14.9	
		REF, DOT, USB	Type 3, $V_{OH} = 1.00V$	-29	
			Type 3, $V_{OH} = 3.135V$	-23	
		3V66, DOT, PCI	Type 5, $V_{OH} = 1.00V$	-33	
			Type 5, $V_{OH} = 3.135V$	-33	
I_{OL}	Low-level Output Current	REF, DOT, USB	Type 3, $V_{OL} = 1.95V$	29	mA
			Type 3, $V_{OL} = 0.4V$	27	
		3V66, PCI	Type 5, $V_{OL} = 1.95V$	30	
			Type 5, $V_{OL} = 0.4V$	38	
I_{OZ}	Output Leakage Current	Three-state		10	mA
I_{DD3}	3.3V Power Supply Current	$V_{DD_CORE}/V_{DD3.3} = 3.465V, F_{CPU} = 133\text{ MHz}$		360	mA
I_{DDPD3}	3.3V Shutdown Current	$V_{DD_CORE}/V_{DD3.3} = 3.465V$		20	mA

Note:

9. **Multiple Supplies:** The voltage on any input or I/O pin cannot exceed the power pin during power-up. Power supply sequencing is NOT required.

Switching Characteristics^[10] Over the Operating Range

Parameter	Output	Description	Test Conditions	Min.	Max.	Unit
t ₁	All	Output Duty Cycle ^[11]	Measured at 1.5V	45	55	%
t ₃	USB, REF, DOT	Falling Edge Rate	Between 2.4V and 0.4V	0.5	2.0	ps
t ₃	PCI,3V66	Falling Edge Rate	Between 2.4V and 0.4V	1.0	4.0	V/ns
t ₅	3V66[0:1]	3V66-3V66 Skew	Measured at 1.5V		500	ps
t ₅	66BUFF[0:2]	66BUFF-66BUFF Skew	Measured at 1.5V		175	ps
t ₆	PCI	PCI-PCI Skew	Measured at 1.5V		500	ps
t ₇	3V66,PCI	3V66-PCI Clock Jitter	3V66 leads. Measured at 1.5V	1.5	3.5	ns
t ₉	3V66	Cycle-Cycle Clock Jitter	Measured at 1.5V t ₉ = t _{9A} - t _{9B}		250	ps
t ₉	USB, DOT	Cycle-Cycle Clock Jitter	Measured at 1.5V t ₉ = t _{9A} - t _{9B}		350	ps
t ₉	PCI	Cycle-Cycle Clock Jitter	Measured at 1.5V t ₉ = t _{9A} - t _{9B}		500	ps
t ₉	REF	Cycle-Cycle Clock Jitter	Measured at 1.5V t ₉ = t _{9A} - t _{9B}		1000	ps
CPU 1.0V Switching Characteristics						
t ₂	CPU	RiseTime	Measured differential waveform from -0.35V to +0.35V	175	467	ps
t ₃	CPU	Fall Time	Measured differential waveform from -0.35V to +0.35V	175	467	ps
t ₄	CPU	CPU-CPU Skew	Measured at Crossover		150	ps
t ₈	CPU	Cycle-Cycle Clock Jitter	Measured at Crossover t ₈ = t _{8A} - t _{8B}		150	ps
	CPU	Rise/Fall Matching	Measured with test loads ^[12]		325	mV
V _{oh}	CPU	High-level Output Voltage including overshoot	Measured with test loads ^[12]	0.92	1.45	V
V _{ol}	CPU	Low-level Output Voltage including undershoot	Measured with test loads ^[12]	-0.2	0.35	V
V _{crossover}	CPU	Crossover Voltage	Measured with test loads ^[12]	0.51	0.76	V
CPU 0.7V Switching Characteristics						
t ₂	CPU	RiseTime	Measured single ended waveform from 0.175V to 0.525V	175	700	ps
t ₃	CPU	Fall Time	Measured single ended waveform from 0.175V to 0.525V	175	700	ps
t ₄	CPU	CPU-CPU Skew	Measured at Crossover		150	ps
t ₈	CPU	Cycle-Cycle Clock Jitter	Measured at Crossover t ₈ = t _{8A} - t _{8B} With all outputs running		150	ps
	CPU	Rise/Fall Matching	Measured with test loads ^[13, 14]		20	%
V _{oh}	CPU	High-level Output Voltage including overshoot	Measured with test loads ^[14]		0.85	V
V _{ol}	CPU	Low-level Output Voltage including undershoot	Measured with test loads ^[14]	-0.15		V
V _{crossover}	CPU	Crossover Voltage	Measured with test loads ^[14]	0.28	0.43	V

Notes:

10. All parameters specified with loaded outputs.
11. Duty cycle is measured at 1.5V when V_{DD} = 3.3V. When V_{DD} = 2.5V, duty cycle is measured at 1.25V.
12. The 1.0V test load is shown on test circuit page.
13. Determined as a fraction of 2*(Trp - Trn)/(Trp + Trn) Where Trp is a rising edge and Trp is an intersecting falling edge.
14. The 0.7V test load is R_s = 33.2Ω, R_p = 49.9Ω in test circuit.



Definition and Application of PWRGD# Signal

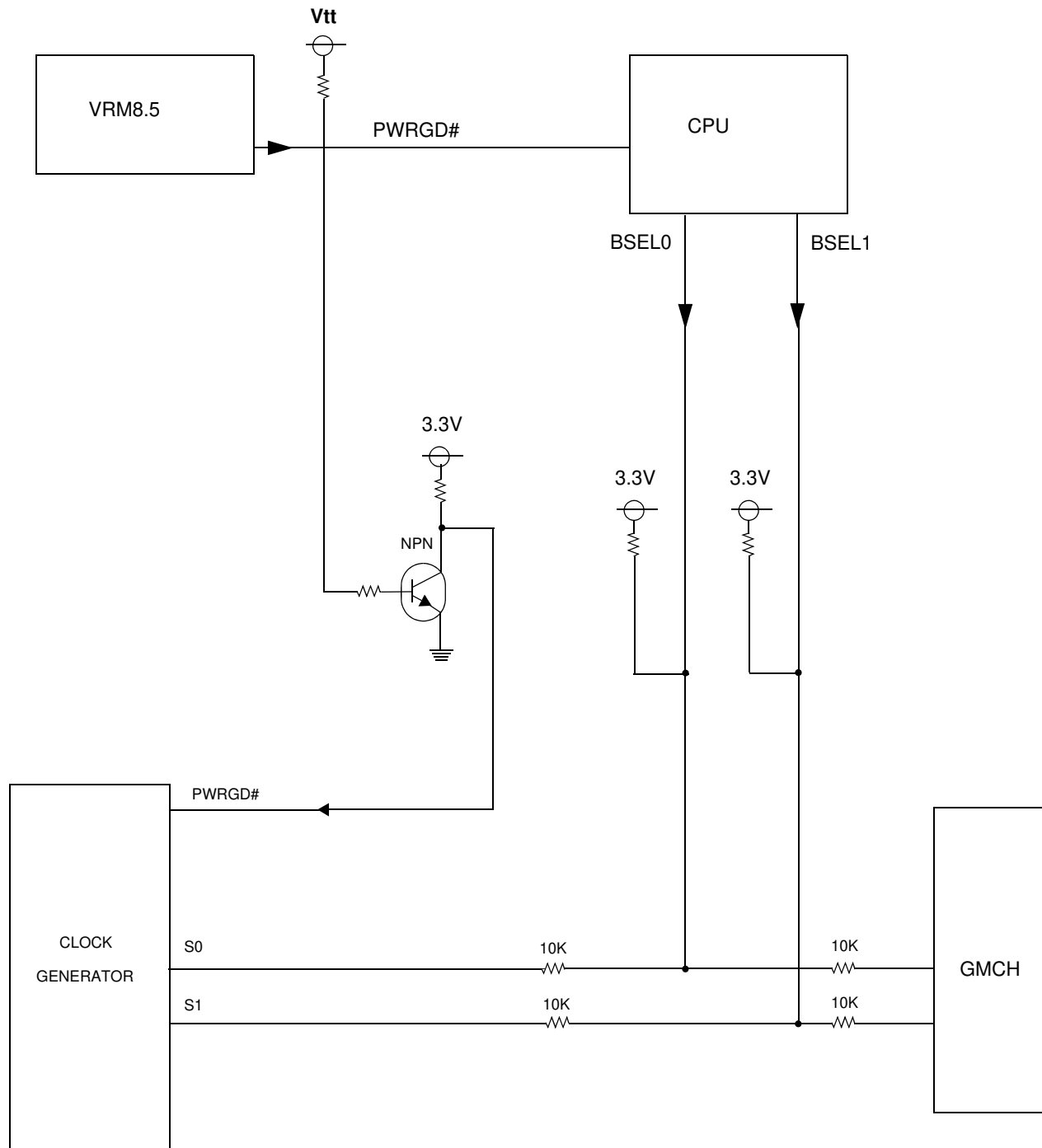



Switching Waveforms

Duty Cycle Timing (Single Ended Output)

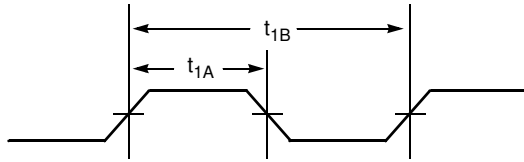

Duty Cycle Timing (CPU Differential Output)

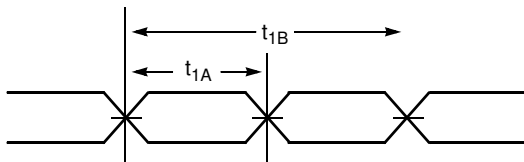

All Outputs Rise/Fall Time

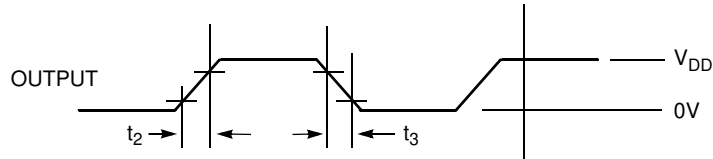

CPU-CPU Clock Skew

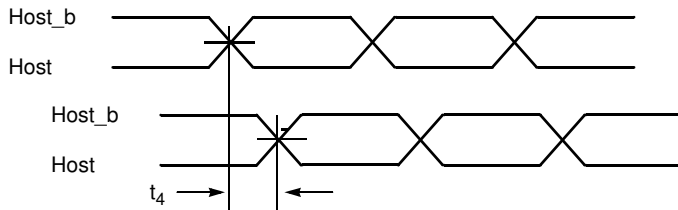

3V66-3V66 Clock Skew

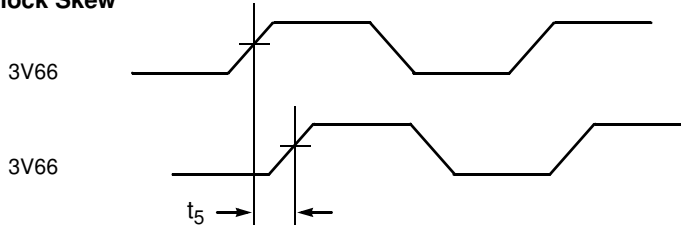

PCI-PCI Clock Skew

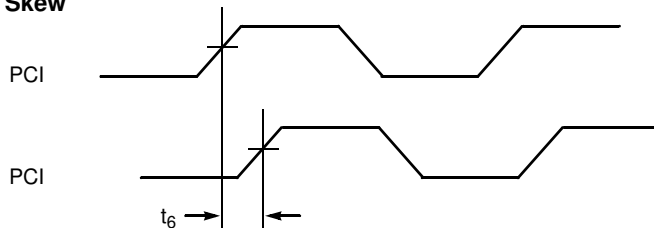



Switching Waveforms (continued)

3V66-PCI Clock Skew

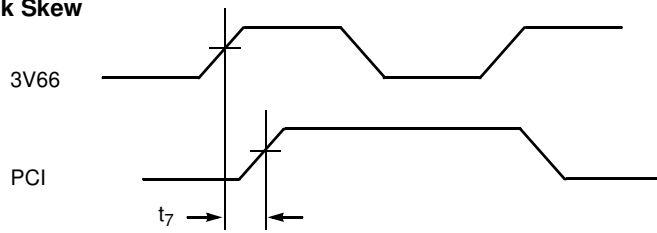

CPU Clock Cycle-Cycle Jitter

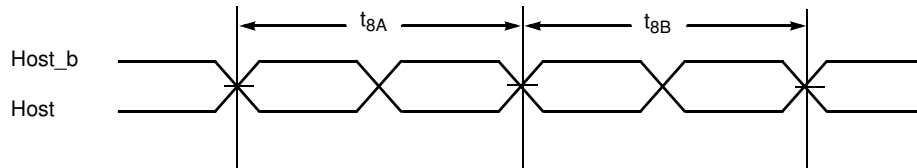

Cycle-Cycle Clock Jitter

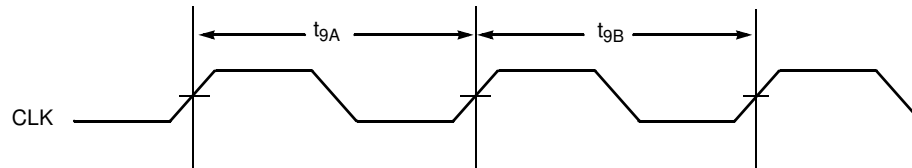

PWRDWN# Assertion^[15]

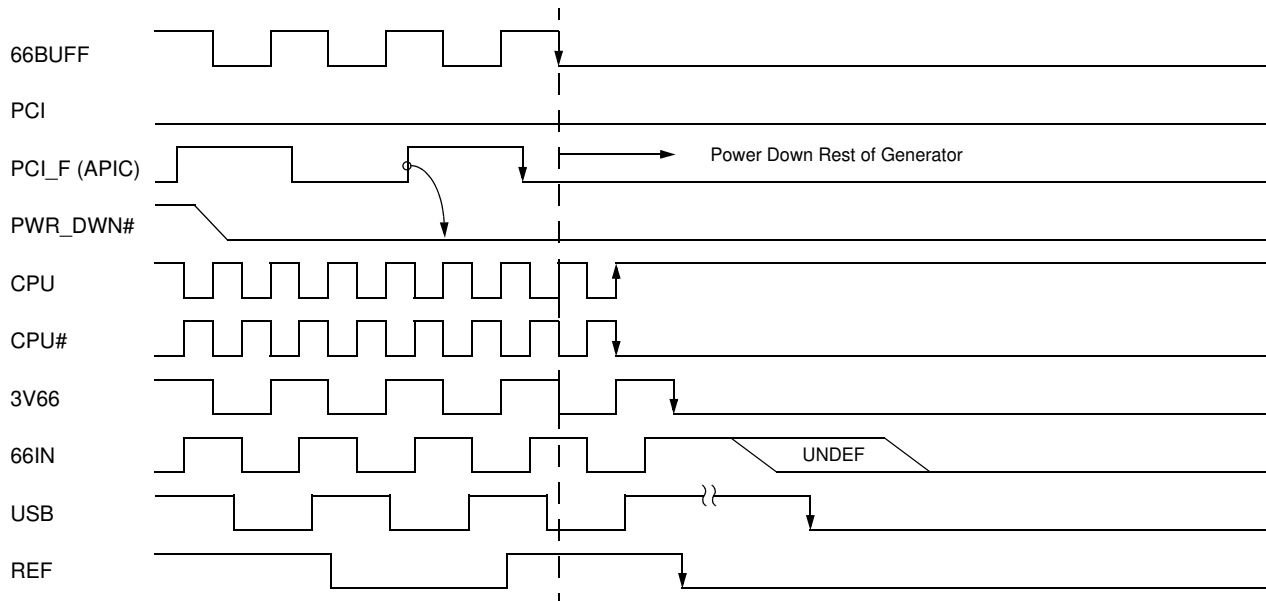

Note:
15. PCI_STOP# asserted LOW.

PWRDWN# Deassertion^[15]

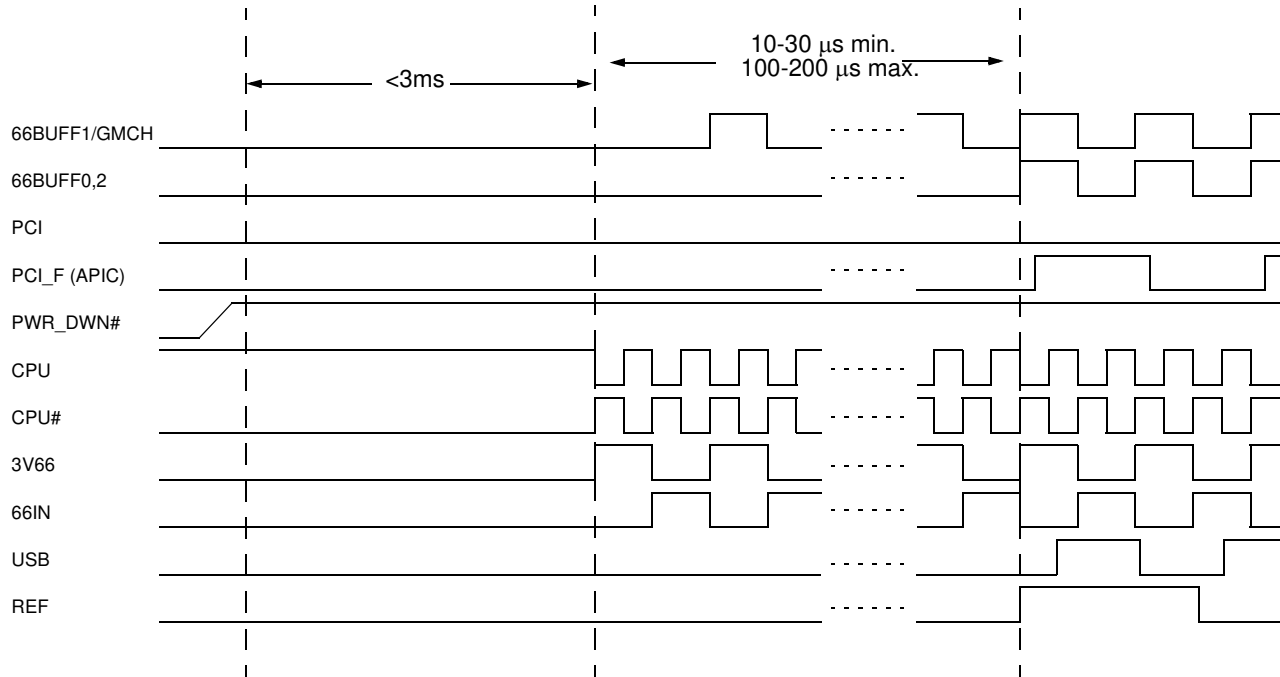

PWRGD# Timing Diagrams

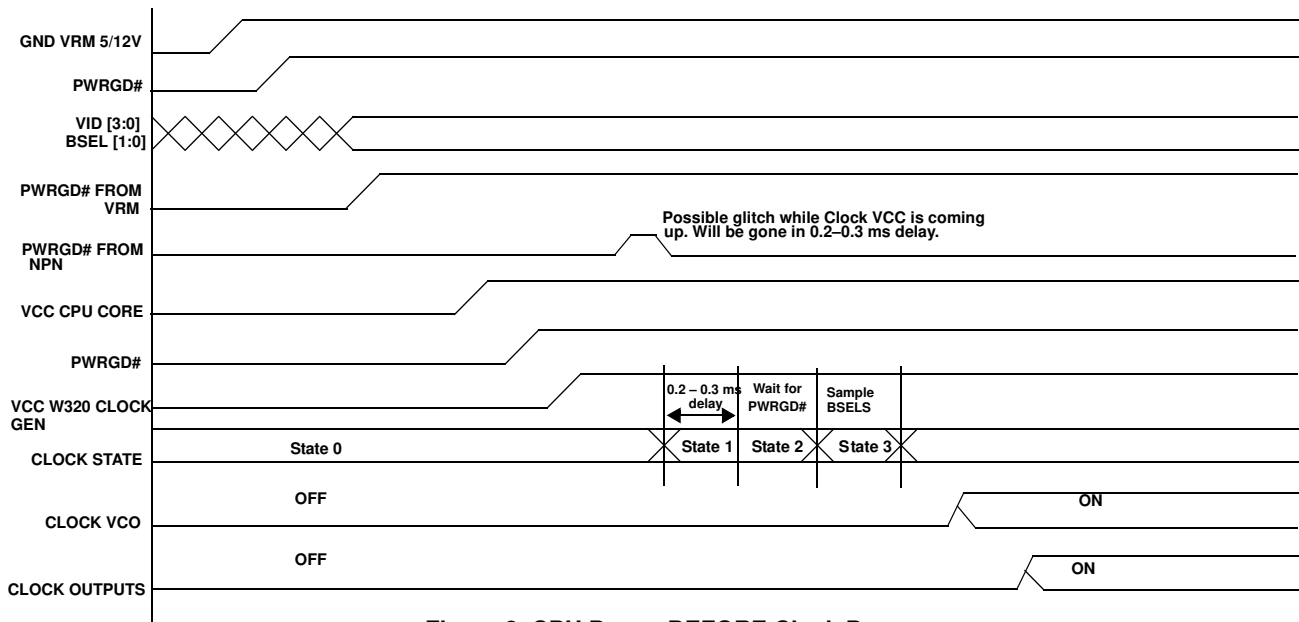

Figure 2. CPU Power BEFORE Clock Power

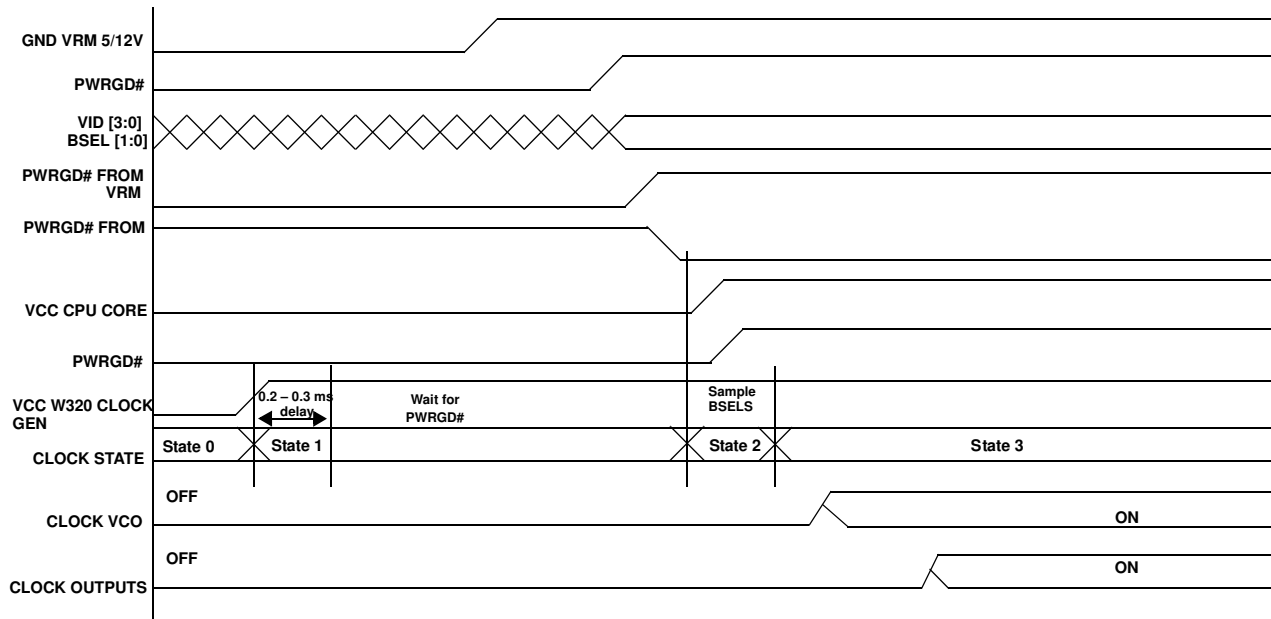
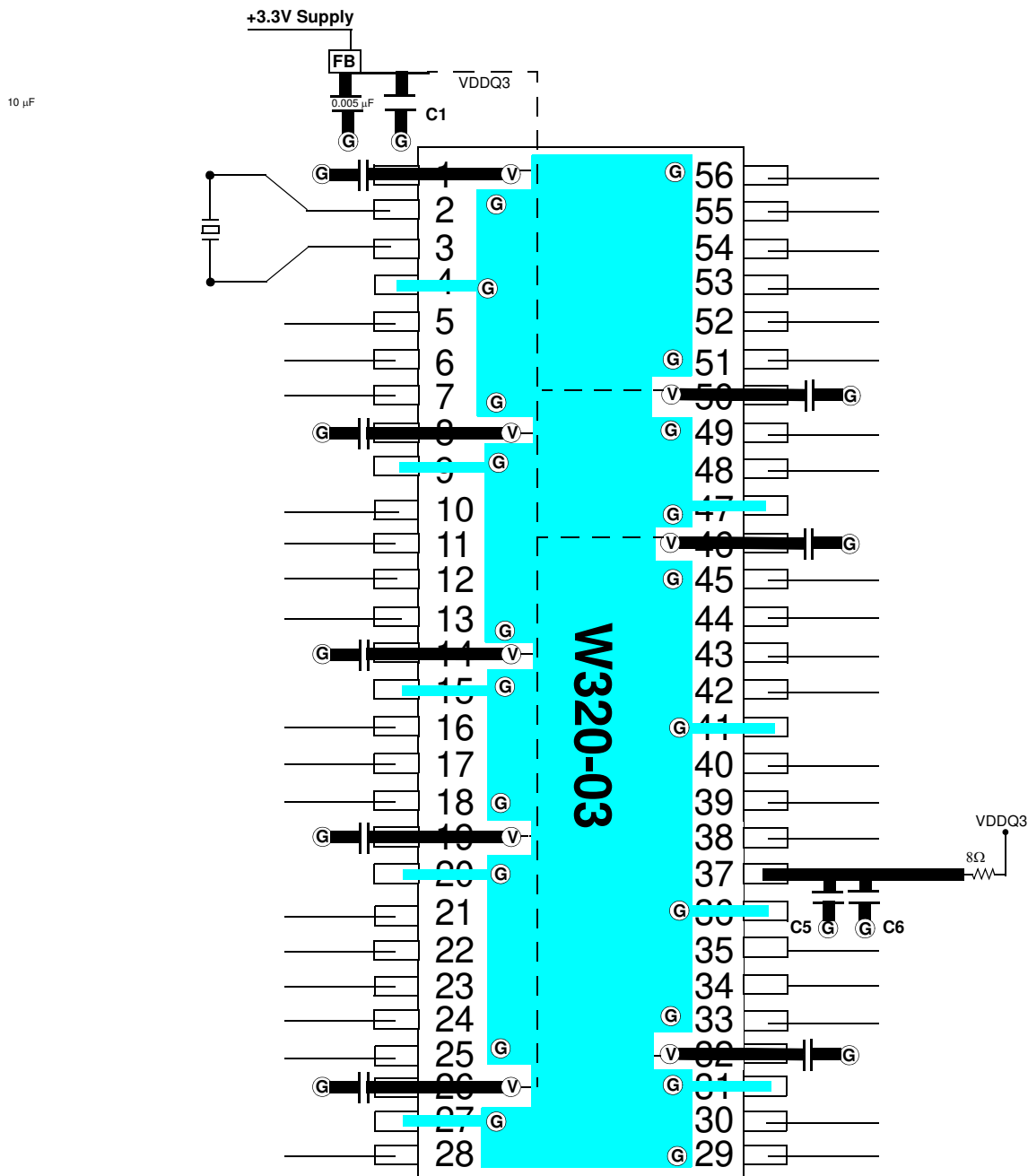

Figure 3. CPU Power AFTER Clock Power



Layout Example



FB = Dale ILB1206 - 300 or 2TDKACB2012L-120 or 2 Murata BLM21B601S

Ceramic Caps C1 = 10–22 μF C2 = 0.005 μF C5 = 0.1 μF C6 = 10 μF

Ⓞ = VIA to GND plane layer Ⓟ = VIA to respective supply plane layer

Note: Each supply plane or strip should have a ferrite bead and capacitors

Test Circuit^[16, 17]

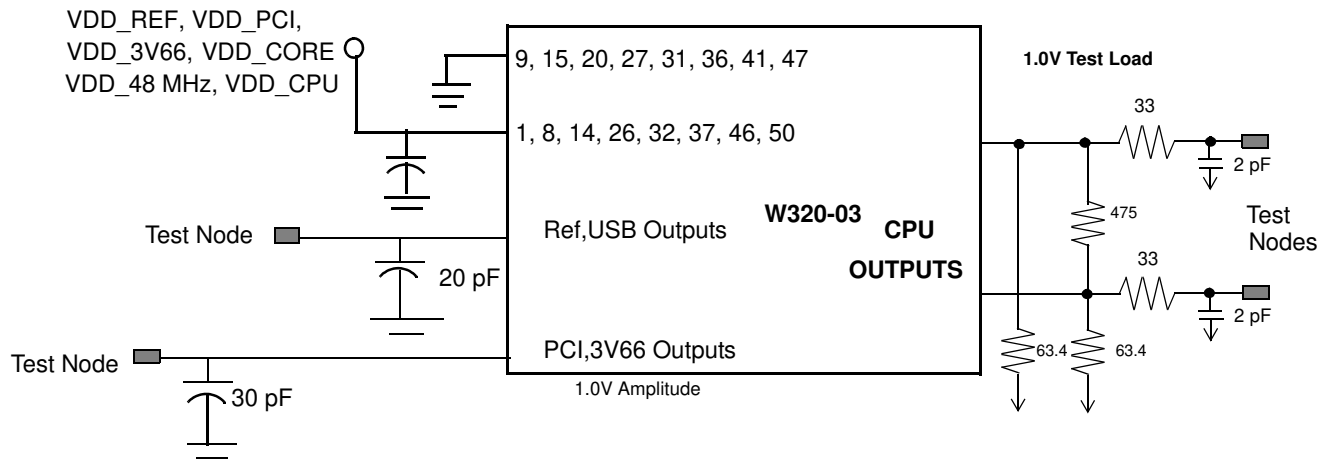
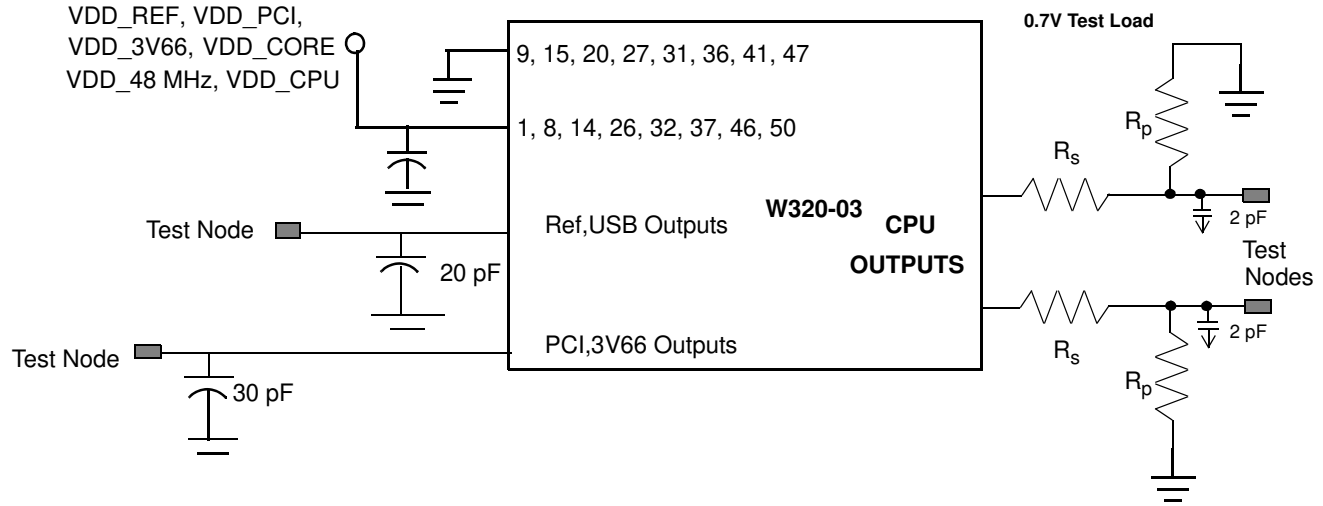

Ordering Information

Ordering Code	Package Type	Operating Range
W320-03H	56-pin SSOP	Commercial
W320-03HT	56-pin SSOP - Tape and Reel	Commercial
W320-03X	56-pin TSSOP	Commercial
W320-03XT	56-pin TSSOP - Tape and Reel	Commercial
Lead-free		
CYW320OXC-3	56-pin SSOP	Commercial
CYW320OXC-3T	56-pin SSOP - Tape and Reel	Commercial

Notes:

- 16. Each supply pin must have an individual decoupling capacitor.
- 17. All capacitors must be placed as close to the pins as is physically possible. 0.7V amplitude: $R_S = 33\Omega$ $R_P = 50\Omega$.

Package Diagrams

56-lead Shrunken Small Outline Package O56

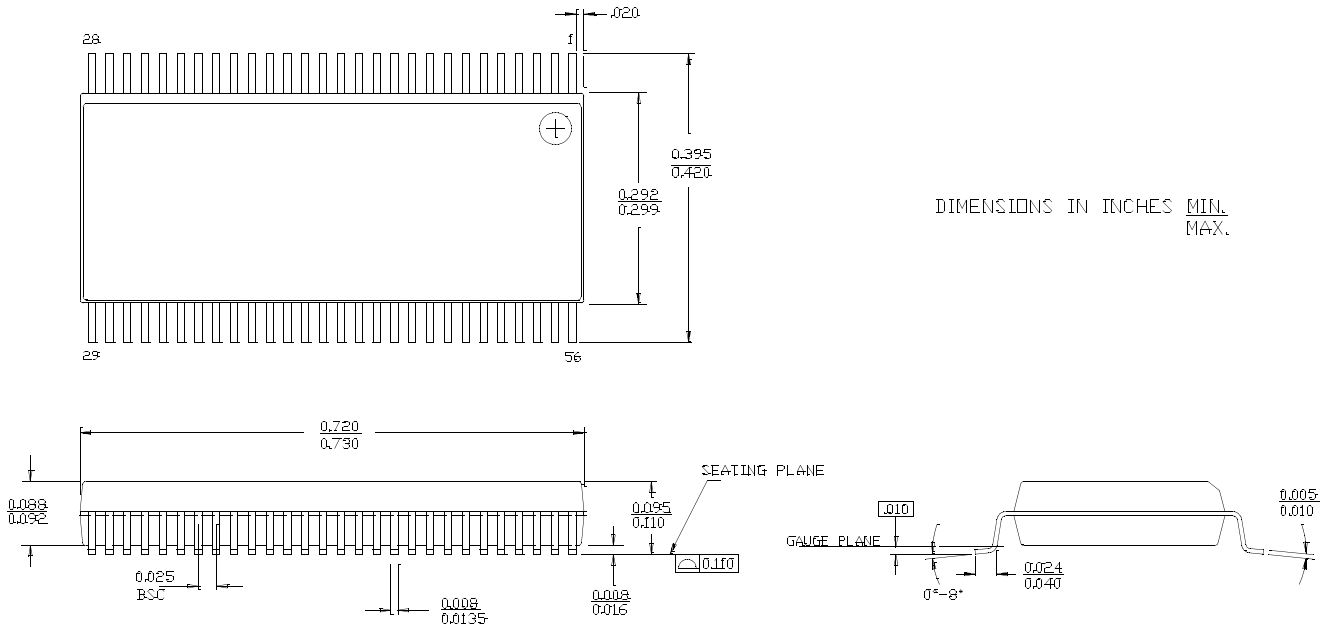

56-Lead Thin Shrunken Small Outline Package, Type II (6 mm x 12 mm) Z56

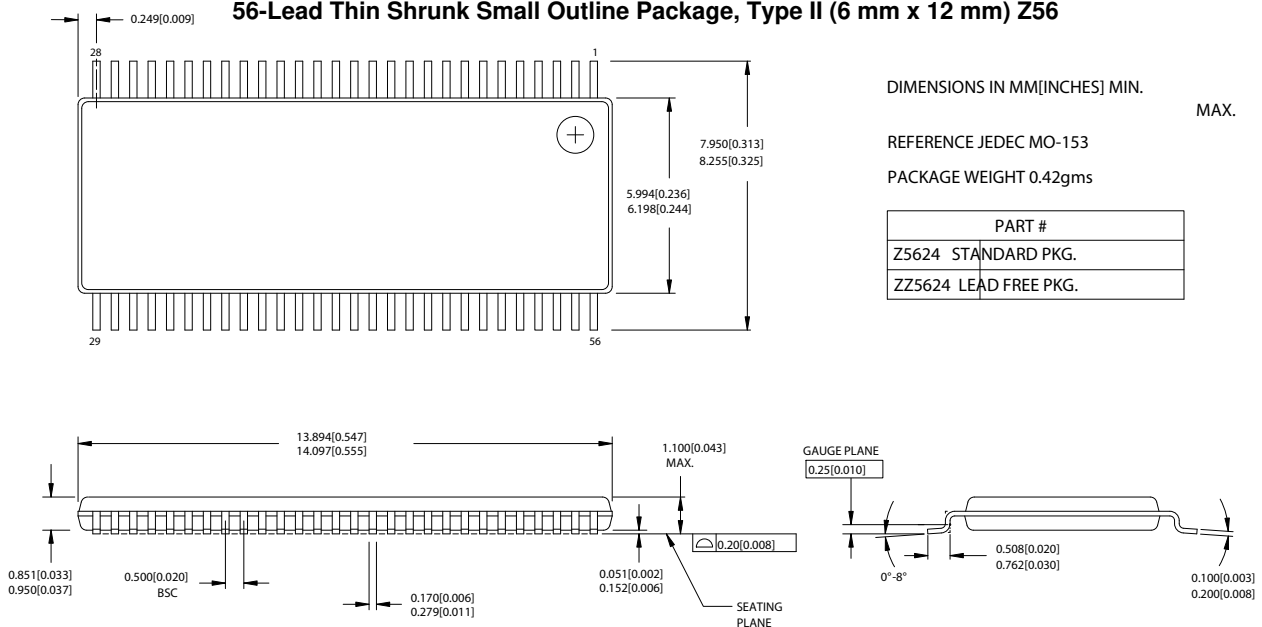

The information in this document is believed to be accurate in all respects at the time of publication but is subject to change without notice. Silicon Laboratories assumes no responsibility for errors and omissions, and disclaims responsibility for any consequences resulting from the use of information included herein. Additionally, Silicon Laboratories assumes no responsibility for the functioning of undescribed features or parameters. Silicon Laboratories reserves the right to make changes without further notice. Silicon Laboratories makes no warranty, representation or guarantee regarding the suitability of its products for any particular purpose, nor does Silicon Laboratories assume any liability arising out of the application or use of any product or circuit, and specifically disclaims any and all liability, including without limitation consequential or incidental damages. Silicon Laboratories products are not designed, intended, or authorized for use in applications intended to support or sustain life, or for any other application in which the failure of the Silicon Laboratories product could create a situation where personal injury or death may occur. Should Buyer purchase or use Silicon Laboratories products for any such unintended or unauthorized application, Buyer shall indemnify and hold Silicon Laboratories harmless against all claims and damages.