

10 9 8 7 6 5 4 3 2 1

NOTES:

1. MATERIALS
 HOUSING - HIGH TEMP. NYLON GLASS FILLED, UL 94 V-0, BLACK.
 EJECTOR - HIGH TEMP. NYLON GLASS FILLED, UL 94 V-0, BLACK.
 TERMINAL - COPPER ALLOY
2. PLATING - SEE TABLE IN SHEET 5.
3. CARD SLOT ACCEPTS 1.27±0.10 MM MODULE THICKNESS.
 (MEASURED OVER P.C. PADS)
4. RECOMMENDED MODULE LAYOUT SHALL BE AS PER JEDEC MO-237.
5. REFER TO PRODUCT SPEC. PS-87978-013 FOR PERFORMANCE SPECIFICATIONS.
6. PRODUCT SHALL BE PACKED IN TRAY.
7. PRODUCT SHALL HAVE DATE CODE STAMPED ON SIDE OF HOUSING.
8. KEEP OUT AREA IS THE AREA WHERE THE CONNECTOR IS MOUNTED ONTO THE PCB WHICH DOES NOT INCLUDE THE LATCH.
9. REFER TO CRITICAL JEDEC INFORMATION FOR SOCKET OUTLINE PER S0-001.
10. DIMM MODULE SEATING PLANE FROM TOP OF PCB.
11. CONTACT MOLEX FOR AVAILABILITY OF PRODUCT OPTIONS.
12. PART NUMBER SHALL BE MARKED LEGIBLY AS 87978-****

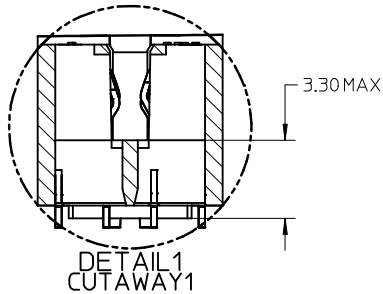
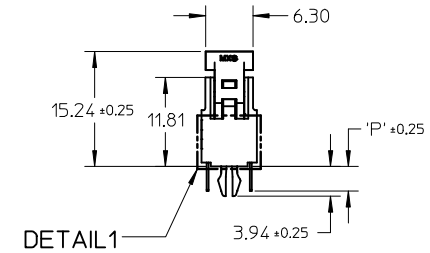
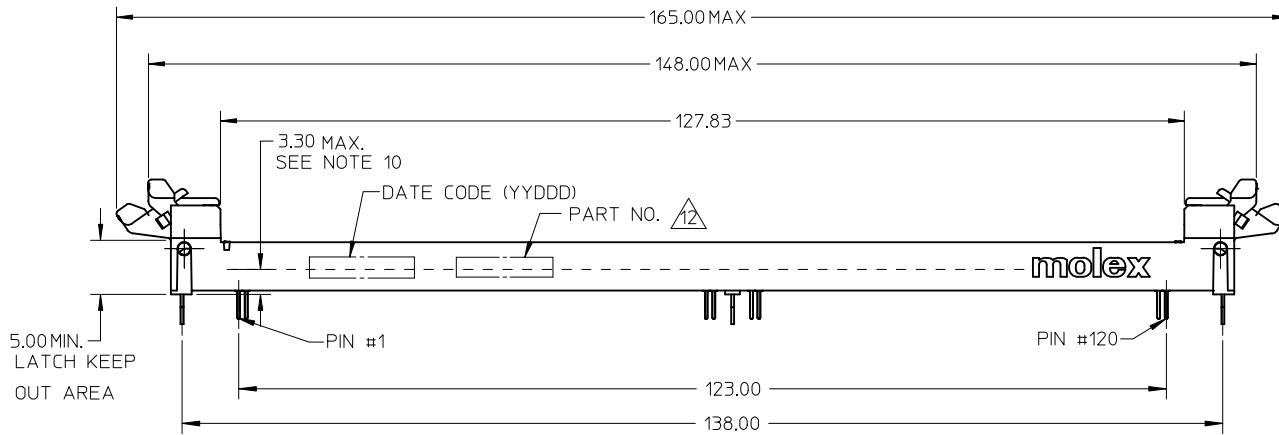
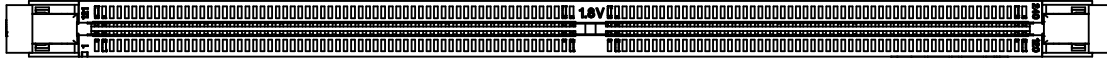

REVISED EC NO: S2008-0235 DRW: CCHTEH CHK: CCHTEH APPR: SHLENI	2007/09/27 2007/09/27 2007/09/28	QUALITY SYMBOLS ▽=0 ◻=0	GENERAL TOLERANCES (UNLESS SPECIFIED)		DIMENSION STYLE MM ONLY	SCALE NTS	DESIGN UNITS METRIC	THIRD ANGLE PROJECTION		
				4 PLACES ± --- ± --- 3 PLACES ± --- ± --- 2 PLACES ± 0.20 ± --- 1 PLACE ± --- ± ---	mm INCH ± --- ± --- ± 0.20 ± --- ± --- ± ---	DRAWN BY CCHTEH	DATE 2005/01/03	TITLE DDR2 DIMM, 1MM PITCH 240 CKTS, FORK-LOCK VERS VLP LATCH		
				ANGULAR ± 5 °	DRAFT WHERE APPLICABLE MUST REMAIN WITHIN DIMENSIONS	CHECKED BY SRRAMESH	DATE 2005/08/30	APPROVED BY GGLEE	DATE 2005/08/30	MOLEX INCORPORATED
						MATERIAL NO. SEE TABLE	DOCUMENT NO. SD-87978-001	SHEET NO. 1 OF 5		

9 8 7 6 5 4 3 2 1

10 9 8 7 6 5 4 3 2 1

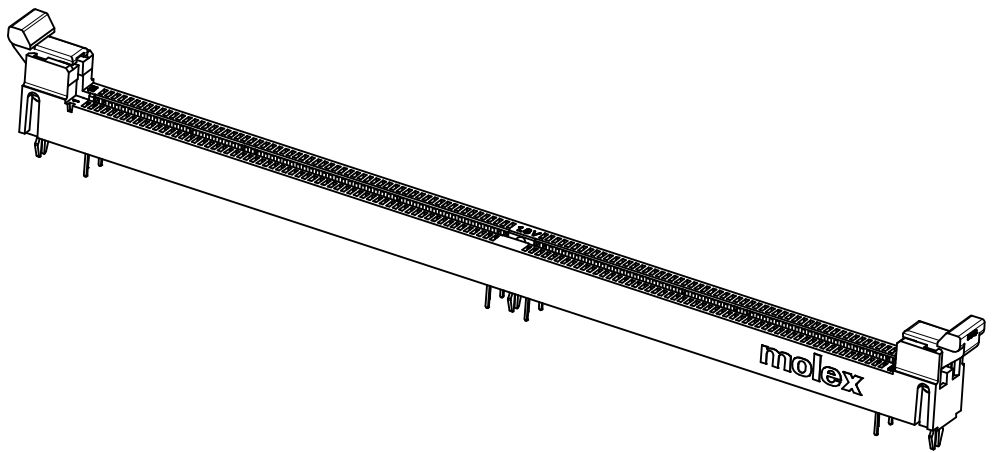
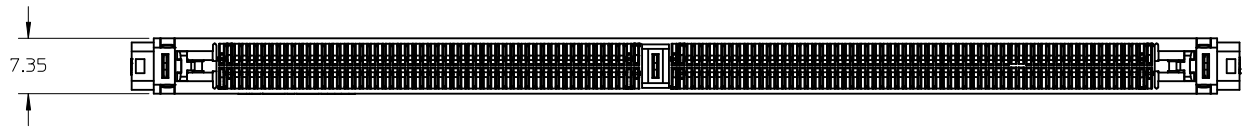

REVISED EC NO: S2008-0235 DRWN: CMTEO 2007/09/27 CHKD: CCTEH 2007/09/27 APPR: SILENI 2007/09/28	DESCRIPTION REV	QUALITY SYMBOLS	GENERAL TOLERANCES (UNLESS SPECIFIED)	DIMENSION STYLE	SCALE	DESIGN UNITS	THIRD ANGLE PROJECTION	
		$\nabla=0$ $\sphericalangle=0$	mm INCH 4 PLACES ± --- ± --- 3 PLACES ± --- ± --- 2 PLACES ± 0.20 ± --- 1 PLACE ± --- ± --- ANGULAR ± 5 °	MM ONLY	NTS	METRIC	DRAWN BY: CCTEH DATE: 2005/01/03 CHECKED BY: SRRAMESH DATE: 2005/08/30 APPROVED BY: GGLEE DATE: 2005/08/30	TITLE
		DRAFT WHERE APPLICABLE MUST REMAIN WITHIN DIMENSIONS	SEE TABLE	MOLEX INCORPORATED SD-87978-001	DDR2 DIMM, 1MM PITCH 240 CKTS, FORK-LOCK VERS VLP LATCH			
		SIZE: A3 THIS DRAWING CONTAINS INFORMATION THAT IS PROPRIETARY TO MOLEX INCORPORATED AND SHOULD NOT BE USED WITHOUT WRITTEN PERMISSION	MATERIAL NO. DOCUMENT NO.	SHEET NO. 2 OF 5				

9 8 7 6 5 4 3 2 1

10 9 8 7 6 5 4 3 2 1

RECOMMENDED MODULE LAYOUT

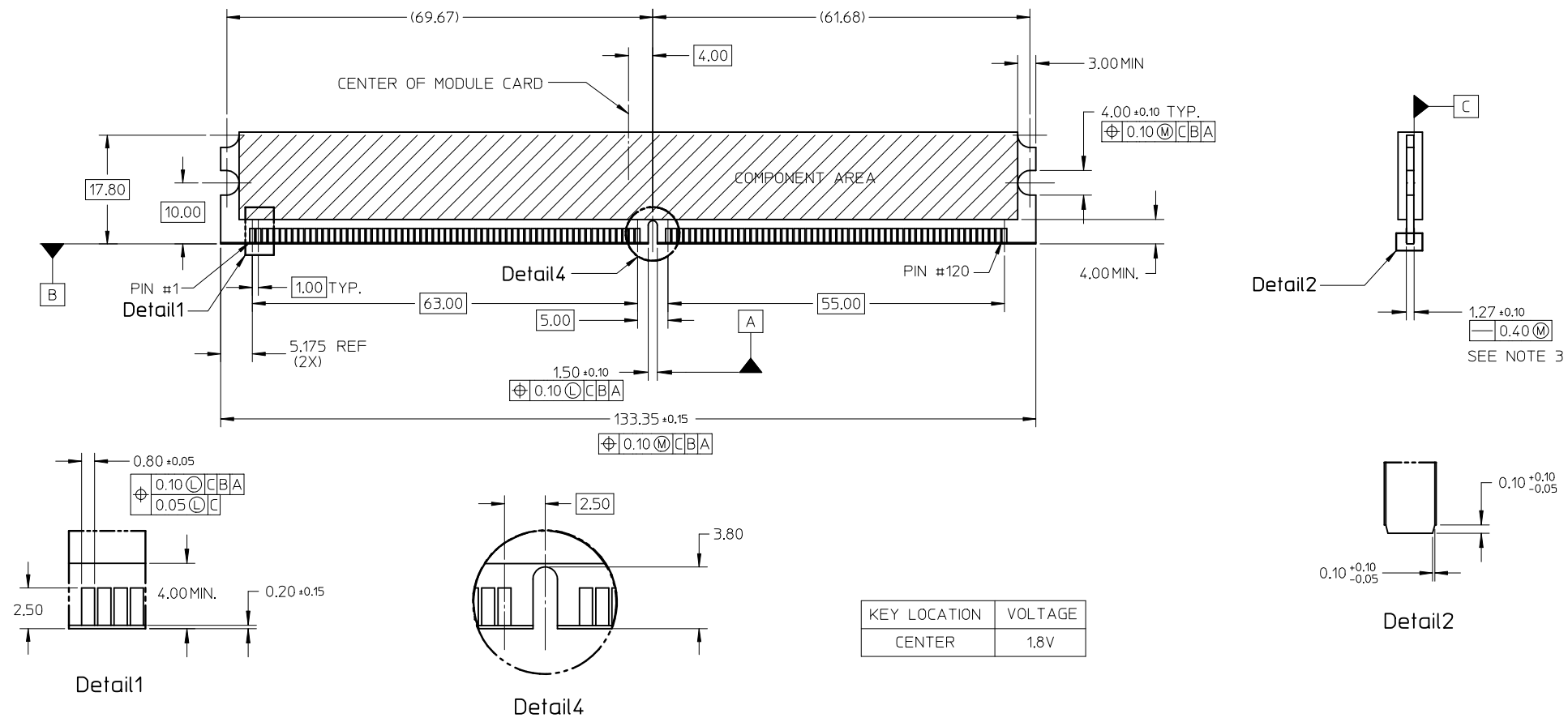

NOTES:
1. MODULE CARD USED FOR TESTS ARE WITH 0.10MM CHAMFER.

REVISED	EC NO: S2008-0235	2007/09/27
DRWN:CMTEO	CHKD:CCTEH	2007/09/27
APPR:SHLENI		2007/09/28

REV	DESCRIPTION
▽=0	QUALITY SYMBOLS
▽=0	

GENERAL TOLERANCES (UNLESS SPECIFIED)	
	mm INCH
4 PLACES	± --- ± ---
3 PLACES	± --- ± ---
2 PLACES	± 0.20 ± ---
1 PLACE	± --- ± ---
ANGULAR ± 5 °	
DRAFT WHERE APPLICABLE MUST REMAIN WITHIN DIMENSIONS	

DIMENSION STYLE	
MM ONLY	
DRAWN BY	DATE
CCTEH	2005/01/03
CHECKED BY	DATE
SRRAMESH	2005/08/30
APPROVED BY	DATE
GGLEE	2005/08/30
MATERIAL NO.	
SEE TABLE	

SCALE	DESIGN UNITS	THIRD ANGLE PROJECTION
NTS	METRIC	
TITLE		
DDR2 DIMM, 1MM PITCH		
240 CKTS, FORK-LOCK VERS		
VLP LATCH		
MOLEX INCORPORATED		SHEET NO.
DOCUMENT NO. SD-87978-001		3 OF 5
THIS DRAWING CONTAINS INFORMATION THAT IS PROPRIETARY TO MOLEX INCORPORATED AND SHOULD NOT BE USED WITHOUT WRITTEN PERMISSION		

9 8 7 6 5 4 3 2 1

10 9 8 7 6 5 4 3 2 1

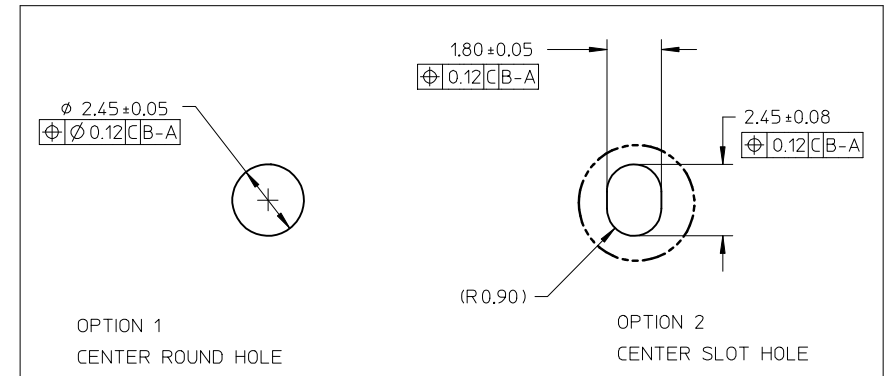

(SEE RECOMMENDED THICKNESS IN TABLE)
RECOMMENDED PCB LAYOUT
CONNECTOR SIDE

Detail3

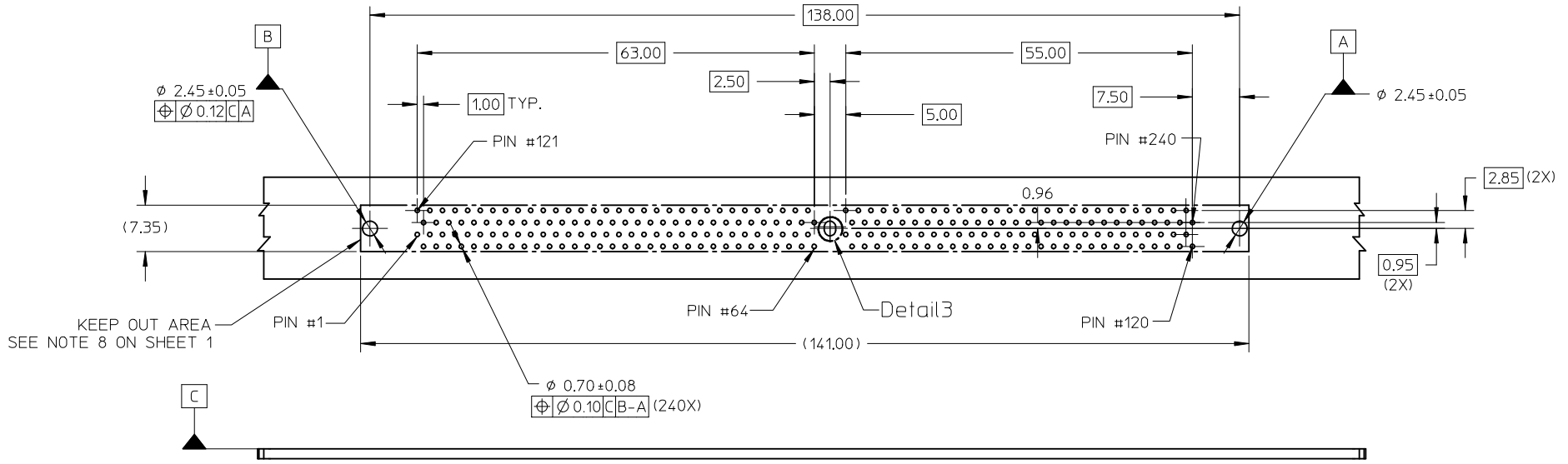

REVISED EC NO: S2008-0235 DRWN:CMTEO 2007/09/27 CHKD:CCTEH 2007/09/27 APPR:SHLENI 2007/09/28	QUALITY SYMBOLS ▽=0 ◻=0	GENERAL TOLERANCES (UNLESS SPECIFIED)		DIMENSION STYLE MM ONLY		SCALE NTS	DESIGN UNITS METRIC	THIRD ANGLE PROJECTION		
			mm	INCH	DRAWN BY	DATE	TITLE			
		4 PLACES	± ---	± ---	CCTEH	2005/01/03	DDR2 DIMM, 1MM PITCH 240 CKTS, FORK-LOCK VERS VLP LATCH			
		3 PLACES	± ---	± ---	CHECKED BY	DATE				
2 PLACES	± 0.20	± ---	SRRAMESH	2005/08/30	MOLEX INCORPORATED					
1 PLACE	± ---	± ---	APPROVED BY	DATE						
	ANGULAR ± 5 °		GGLEE	2005/08/30	MATERIAL NO. SEE TABLE		DOCUMENT NO. SD-87978-001		SHEET NO. 4 OF 5	
DRAFT WHERE APPLICABLE MUST REMAIN WITHIN DIMENSIONS			THIS DRAWING CONTAINS INFORMATION THAT IS PROPRIETARY TO MOLEX INCORPORATED AND SHOULD NOT BE USED WITHOUT WRITTEN PERMISSION							

9 8 7 6 5 4 3 2 1

PART NO.	KEY POS.	DIM 'P'	RECOMMENDED PCB THICKNESS	PLATING OPTION	LATCH COLOR
87978-0021	CENTER (1.8V)	2.67	1.57	0.38µM / 15 µIN MIN. GOLD ON CONTACT, 2.54µM/ 100µIN MIN. TIN ON SOLDER TAILS, 1.27µM/ 50µIN MIN. NICKEL UNDERPLATE	BLACK
87978-1021	CENTER (1.8V)	3.18	2.36		
87978-0031	CENTER (1.8V)	2.67	1.57	0.03µM / 1 µIN MIN. GOLD ON CONTACT, 2.54µM/ 100µIN MIN. TIN ON SOLDER TAILS, 1.27µM/ 50µIN MIN. NICKEL UNDERPLATE	
87978-1031	CENTER (1.8V)	3.18	2.36		
87978-0051	CENTER (1.8V)	2.67	1.57	0.76µM / 30 µIN MIN. GOLD ON CONTACT, 2.54µM/ 100µIN MIN. TIN ON SOLDER TAILS, 1.27µM/ 50µIN MIN. NICKEL UNDERPLATE	
87978-1051	CENTER (1.8V)	3.18	2.36		

REVISED EC NO: S2008-0235 DRWN: CMTEO 2007/09/27 CHKD: CCTEH 2007/09/27 APPR: SHLENI 2007/09/28 REV/ DESCRIPTION	QUALITY SYMBOLS	GENERAL TOLERANCES (UNLESS SPECIFIED)	DIMENSION STYLE	SCALE	DESIGN UNITS	THIRD ANGLE PROJECTION	
	▼ = 0 ◻ = 0	mm INCH 4 PLACES ± --- ± --- 3 PLACES ± --- ± --- 2 PLACES ± 0.20 ± --- 1 PLACE ± --- ± --- ANGULAR ± 5 °	MM ONLY	NTS	METRIC	☉ ◻ THIRD ANGLE PROJECTION	
	DRAWN BY: CCTEH DATE: 2005/01/03 CHECKED BY: SRRAMESH DATE: 2005/08/30 APPROVED BY: GGLEE DATE: 2005/08/30	DRAFT WHERE APPLICABLE MUST REMAIN WITHIN DIMENSIONS		TITLE: DDR2 DIMM, 1MM PITCH 240 CKTS, FORK-LOCK VERS VLP LATCH		MOLEX INCORPORATED	
	MATERIAL NO. SEE TABLE SIZE A3	THIS DRAWING CONTAINS INFORMATION THAT IS PROPRIETARY TO MOLEX INCORPORATED AND SHOULD NOT BE USED WITHOUT WRITTEN PERMISSION		DOCUMENT NO. SD-87978-001	SHEET NO. 5 OF 5		