

Style M Connectors

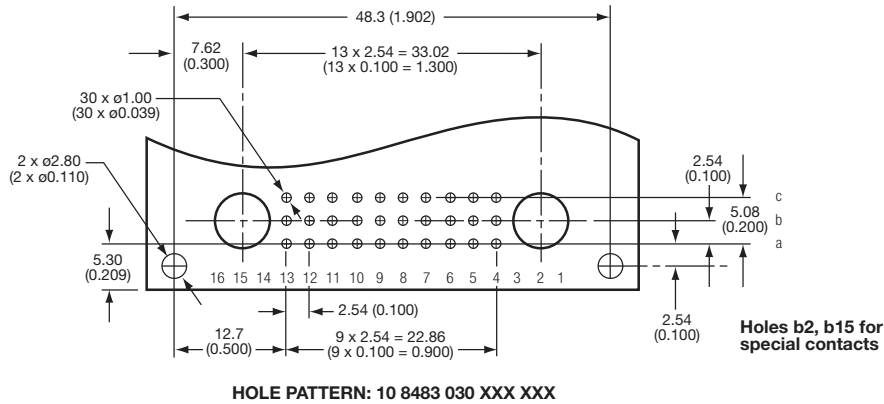

Board Layouts

STYLE 1/2 M

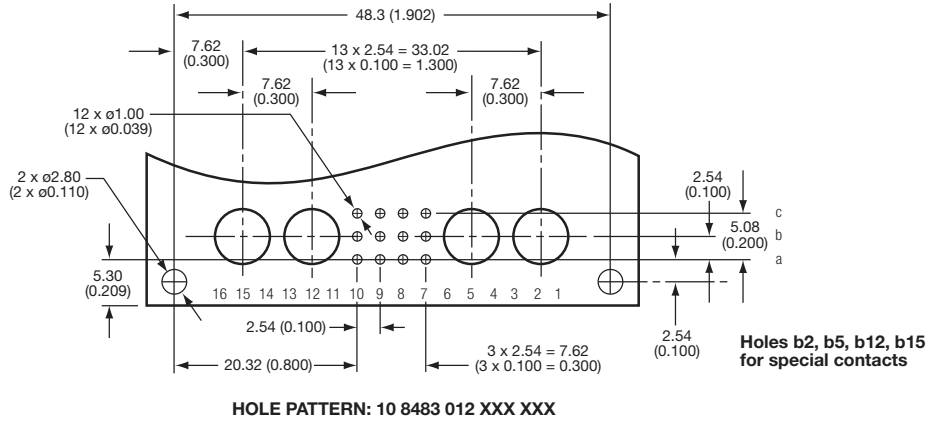

STYLE M

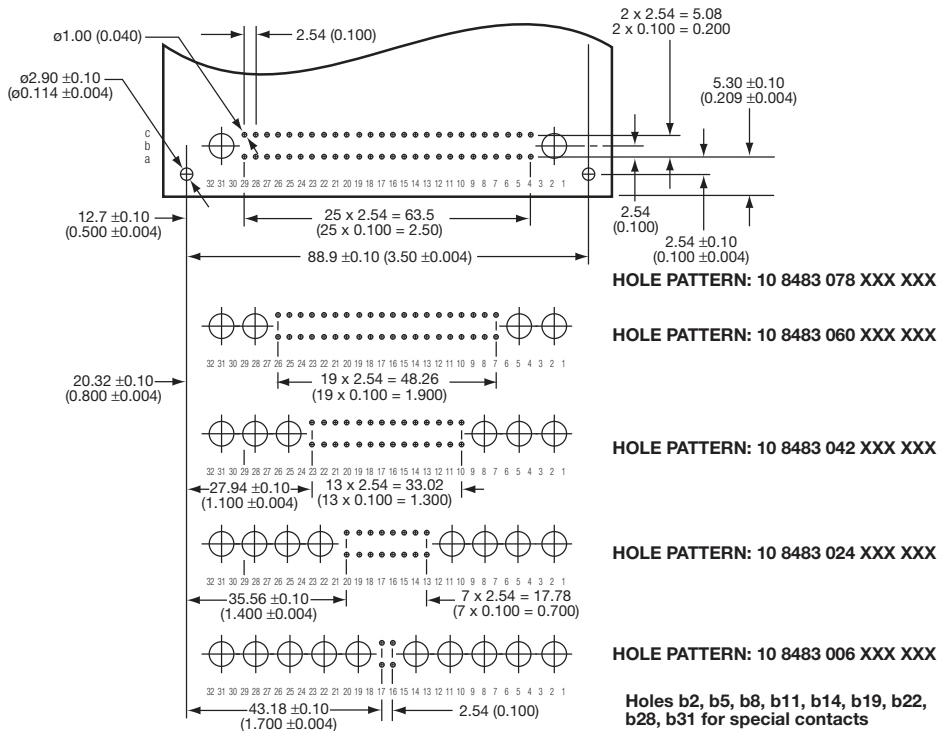

Style M Contacts



Series 8489 – Special Contacts for Style M Connectors

COAX PLUG CONTACT FOR RECEPTACLE SERIES 8483/8484 Dimensions: mm/inches

Variation	Termination		Dimensions			Wire Type	Order Code
	Outer Conductor	Inner Conductor	ØA	ØB	ØC		
	CRIMP	SOLDER	1.05/0.041	1.70/0.067	2.25/0.089	RG 196, 178	60 8489 020 001 049
	CRIMP	SOLDER	1.70/0.067	2.70/0.106	3.20/0.126	RG 179, 316 (single), RG 187	60 8489 020 002 049
	CRIMP	SOLDER	1.70/0.067	2.70/0.106	3.58/0.141	RG 316 (braided), RG 187 (double)	60 8489 020 003 049
	SOLDER	SOLDER	1.30/0.051	1.90/0.075	2.20/0.087	RG 178	60 8489 020 004 049
	SOLDER	SOLDER	2.25/0.089	2.90/0.114	3.20/0.126	RG 179	60 8489 020 005 049
	CRIMP	SOLDER	1.05/0.041	1.70/0.067	2.25/0.089	RG 178	60 8489 020 006 049
	CRIMP	SOLDER	1.70/0.067	2.70/0.106	3.20/0.126	RG 179	60 8489 020 007 049
	CRIMP	SOLDER	1.70/0.067	2.70/0.106	3.55/0.140	RG 187	60 8489 020 008 049
	CRIMP	SOLDER	1.05/0.041	1.70/0.067	2.25/0.089	RG 178	60 8489 020 009 049
	CRIMP	SOLDER	1.70/0.067	2.70/0.106	3.20/0.126	RG 316 (single), RG 179	60 8489 020 010 049
	CRIMP	SOLDER	1.70/0.067	2.70/0.106	3.55/0.140	RG 187	60 8489 020 011 049
	P.C. (1)	P.C. (1)				RG 316 (double)	60 8489 020 012 049

(1) Not applicable for receptacles with P.C. and Press-Fit termination.

Style M Contacts



Series 8489 – Special Contacts for Style M Connectors

COAX RECEPTACLE CONTACT FOR PLUG SERIES 8483

Dimensions: mm/inches

Variation	Termination		Dimensions			Wire Type	Order Code
	Outer Conductor	Inner Conductor	ØA	ØB	ØC		Perf. Class I
	CRIMP	SOLDER	1.70/0.067	2.70/0.106	3.55/0.140	RG 187	60 8489 030 001 049
	CRIMP	SOLDER	1.70/0.067	2.70/0.106	3.20/0.126	RG 316, RG 179, RG 188, RG 174	60 8489 030 002 049
	CRIMP	SOLDER	1.05/0.041	1.70/0.067	2.25/0.089	RG 178	60 8489 030 003 049
	SOLDER	SOLDER	2.25/0.089	2.90/0.114	3.20/0.126	RG 179	60 8489 030 004 049
	SOLDER	SOLDER	1.30/0.051	1.90/0.075	2.20/0.087	RG 178	60 8489 030 005 049
	CRIMP	SOLDER	1.70/0.067	2.70/0.106	3.20/0.126	RG 179	60 8489 030 006 049
	CRIMP	SOLDER	1.05/0.041	1.70/0.067	2.25/0.089	RG 178	60 8489 030 007 049
	P.C.	P.C.					60 8489 030 008 049

HIGH VOLTAGE PLUG CONTACT FOR RECEPTACLE SERIES 8483/8484

Variation	Termination	Performance	Ordering Code
			Perf. Class I
	SOLDER CABLE OUTLET STRAIGHT AWG 20 maximum	2.8 KV max	60 8489 070 001 049
	SOLDER CABLE OUTLET 90° AWG 20 maximum	2.8 KV max	60 8489 070 002 049

Style M Contacts



Series 8489 – Special Contacts for Style M Connectors

HIGH VOLTAGE RECEPTACLE CONTACT FOR PLUG SERIES 8483/8484

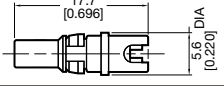
Variation	Termination	Performance	Ordering Code
			Perf. Class I
	SOLDER CABLE OUTLET STRAIGHT AWG 20 maximum	2.8 KV max	60 8489 060 001 049
	SOLDER CABLE OUTLET 90° AWG 20 maximum	2.8 KV max	60 8489 060 002 049

HIGH POWER PLUG CONTACT FOR PLUG SERIES 8483/8484

mm (inches)

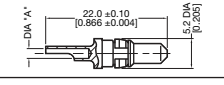
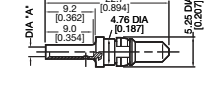
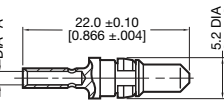
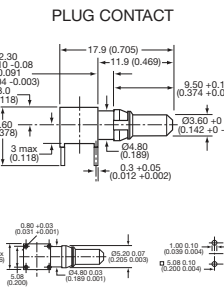
Variation	Termination	ØA*	Performance	Ordering Code
	SOLDER	.189 (4.80)	40 Ampere max.	60 8489 040 001 049
	SOLDER	.138 (3.50)	30 Ampere max.	60 8489 040 002 049
	SOLDER	.110 (2.80)	20 Ampere max.	60 8489 040 003 049
	CRIMP	.189 (4.80)	40 Ampere max.	60 8489 040 005 049
	CRIMP	.138 (3.50)	30 Ampere max.	60 8489 040 006 049
	CRIMP	.110 (2.80)	20 Ampere max.	60 8489 040 007 049
	CRIMP	.067 (1.70)	10 Ampere max.	60 8489 040 008 049
	P.C.	Contact	40 Ampere max.	60 8489 040 009 049

HIGH POWER RECEPTACLE CONTACT FOR RECEPTACLE SERIES 8483/8484

mm (inches)

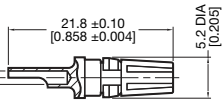
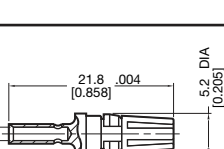
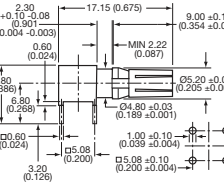
Variation	Termination	ØA*	Performance	Ordering Code
	SOLDER	.189 (4.80)	40 Ampere max.	60 8489 050 001 049
	SOLDER	.138 (3.50)	30 Ampere max.	60 8489 050 002 049
	SOLDER	.110 (2.80)	20 Ampere max.	60 8489 050 003 049
	SOLDER	.067 (1.70)	10 Ampere max.	60 8489 050 004 049
	CRIMP	.189 (4.80)	40 Ampere max.	60 8489 050 005 049
	CRIMP	.138 (3.50)	30 Ampere max.	60 8489 050 006 049
	CRIMP	.110 (2.80)	20 Ampere max.	60 8489 050 007 049
	CRIMP	.067 (1.70)	10 Ampere max.	60 8489 050 008 049
	P.C.	Contact	40 Ampere max.	60 8489 050 009 049

*ØA: inner diameter of contact sleeve.

Style M Contacts



Series 8489 – Special Contacts for Style M Connectors

TECHNICAL DATA

	Coaxial Contacts	High Voltage Contacts	High Current Contacts
Contact Material	copper alloy	copper alloy	copper alloy
Contact Plating	gold over nickel	gold over nickel	gold over nickel
Performance Class	1 - 500 mating cycles	1 - 500 mating cycles	1 - 500 mating cycles
Insulator Material	PTFE	PTFE	
Temperature Range	-55°C ~ +125°C	-55°C ~ +125°C	-55°C ~ +125°C
Maximum Current	0.5 ampere	0.5 ampere	10, 20, 30, 40 ampere
Operating Voltage	250 V eff.	2.8 KV	
Peak Voltage	750 V eff.	3.8 KV	
Contact Resistance	3 Mohm max. (1) 10 Mohm max. (2)	< 3 Mohm max.	< 1 Mohm max.
Insulation Resistance	10,000,000 Mohm	10,000,000 Mohm	
Insertion Force (max.)	10 N	3 N	10 N
Retention Force (min.)	0.9 N	0.8 N	1.6 N
Characteristic Impedance	50 Ohm		
Working Frequency	ca. 30 GHz max. 0-10 GHz opt.		
Reflection Coefficient	max. 0.05 to 1 GHz max. 0.07 to 4 GHz max. 0.1 to 10 GHz		

(1) Outer Conductor

(2) Inner Conductor

Style M Tooling

Series 8489 – Tools for Special Contacts for Style M Connectors



CRIMPING PLIER FOR HIGH POWER CONTACTS

Part Number
06 8489 001 010 000



CRIMPING PLIER FOR COAX CONTACTS (WITHOUT CRIMPING INSERTS)

Part Number
36 8489 001 020 001



CRIMPING INSERTS

Part Number	Cable Type
66 8489 00 102 1 000	RG 196 A/U RG 178 B/U
66 8489 00 102 2 000	RG 188 A/U RG 174 A/U RG 316 /U RG 179 B/U RG 187 A/U
66 8489 00 102 3 000	RG 316 /U

EXTRACTION TOOL FOR ALL CONTACT TYPES

Part Number	Length
06 8489 001 001 000	2.755 (70.00)
06 8489 001 002 000	7.874 (200.00)
06 8489 001 003 000	Replacement Tip

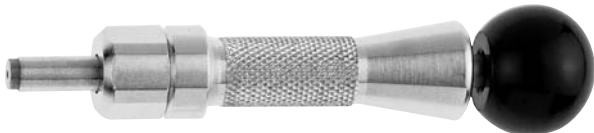

Style M Contacts



Series 8489 – Special Contacts for Style M Connectors

HIGH POWER RECEPTACLE CONTACT FOR RECEPTACLE SERIES 8484

Variation	Termination	ØA*	Performance	Ordering Code
	Screw Ø3M	.114 (2.90) for .118 (3.00) PCB hole Note: set PCB hole spec drilled hole 3.1-0.02 finish hole 3.0+0.04-0.06	40 Ampere max.	70 8485 0214 00 343
	Press-Fit		40 Ampere max.	70 8485 0314 00 343

NB: Please refer to page 49 for other special contacts and tools for Press-Fit Style M Connectors.