

PRODUCT NUMBER
87690-YXXRLF

- RoHS COMPATIBLE, SEE NOTE 6
- OPTION, NOTE 4.
- PIN STYLE, SHEET 2.

PLATING

- 1 = 0.76µm FULL GOLD/GXT, OVER 1.27µm Ni MIN
- 3 = 2µm MATTE TIN, OVER 1.27µm Ni MIN
- 7 = FULL GOLD FLASH, OVER 1.27µm Ni MIN
- 8 = 0.38µm FULL GOLD/GXT, OVER 1.27µm Ni MIN
- G = 0.76µm GOLD/GXT IN ZONE "A", 2µm MATTE TIN IN ZONE "B"
ALL OVER 1.27µm Ni MIN

NOTES:

1. HOUSING MAT'L : HIGH TEMPERATURE THERMOPLASTIC. UL94V-0 COLOR: BLACK.
2. PIN MATERIAL : PHOSPHOR BRONZE.
3. 12N MIN RETENTION IN EITHER DIRECTION.
4. R = FOR RETENTION FEATURE DETAILS, SEE SHEET 3.
OMIT IF FEATURE NOT APPLICABLE
V = BLIBOX PACKAGING FOR CUSTOMER DEDICATED PARTS
5. STANDARD PACKAGING IN POLYBAGS.
6. RoHS COMPATIBLE PRODUCT SPECIFICATIONS

a - PLATING:

- "LF" MEANS THE PRODUCT IS LEAD-FREE, 2µm MINIMUM MATTE TIN OVER 1.27µm MINIMUM NICKEL UNDERPLATE.

b - MANUFACTURING PROCESS COMPATIBILITY

- THE HOUSING WILL WITHSTAND EXPOSURE TO 260°C ±5°C SOLDER BATH TEMPERATURE FOR 5 SECONDS IN A WAVE SOLDER APPLICATION WITH A 1.6mm MIN THICK CIRCUIT BOARD.

c - LABELING:

- MEETS PACKAGING SPECS AS PER GS-14-920

d - LEGAL STATEMENT: SEE GS-47-0004

- 7. FOR 87690-125LF : 0.76µm GXT IN ZONE "A"
2µm MIN MATTE TIN IN ZONE "B"

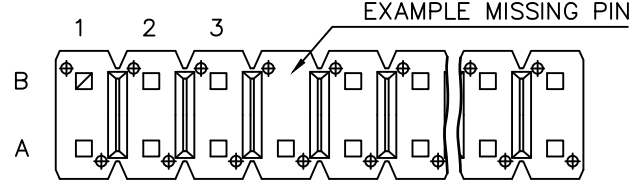
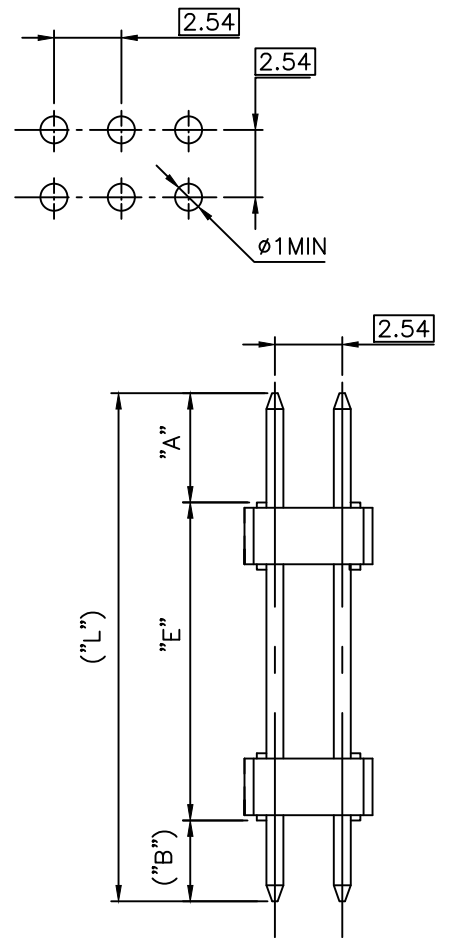
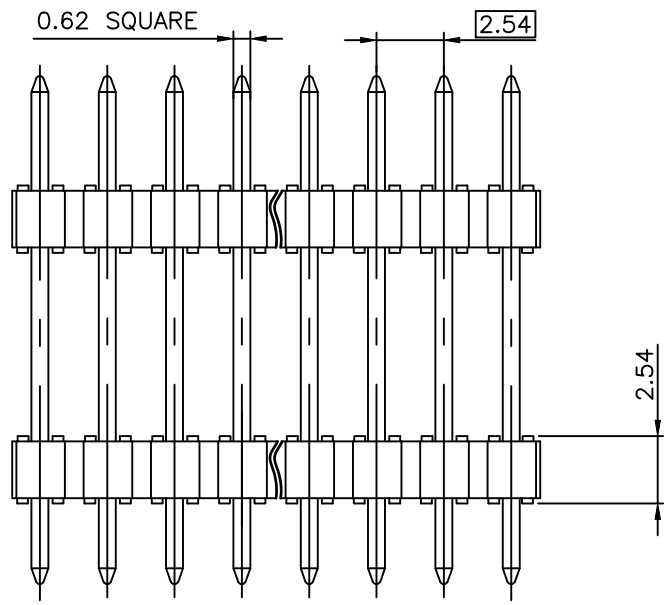
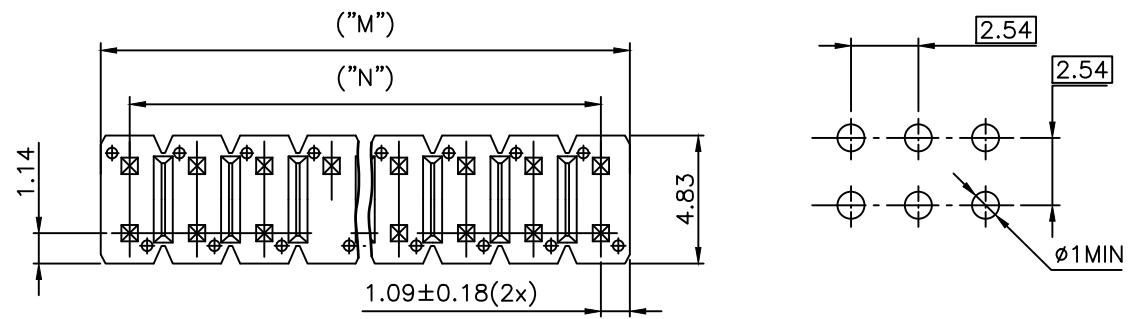

BOTTOM VIEW

mat'l. code		surface		tolerance		projection		product family	
SEE NOTES		ISO 1302		ISO 406 ISO 1101		mm		BERGSTIK	
ltr	ecn no	dr	date	tolerances unless otherwise specified		mm		title	
V	F12-0043	LMU	12.05.02	angles	linear	mm		HEADER STR,DR	
W	B-19782	AMA	14.12.18			scale 5:1		DOUBLE BODY POL	
X	B-21151	AMA	15.06.15					dwg no	
Y	F-22417	JJU	15.11.05	dr	D. MATHEVON	96.06.07		sheet 1 of 3	
AA	F23090	JCO	16.01.20	enr	COMPAGNON	96.06.07		size	
AB	F-31897	LMU	18.11.19	chr	JMC	96.06.07		87690	
AC	F-35412	LMU	19.11.18	appd	JMC	96.06.07		A3	
sheet	revision	AC	Y	G				type	
index	sheet	1	2	3				CUSTOMER Drawing	

PRODUCT NUMBER	PRODUCT DIMENSIONS							VIEW OF MISSING PINS POSITION FROM BOTTOM VIEW							
	NBR POS	"A" ±0.2	"E" ±0.25	"B" ±0.25	("L") REF	("M") REF	("N") REF	1	5	10	15	20	25	30	35
87690-X07	2x10	11.96	18.5	3.2	33.66	25.4	22.86								
87690-X10	2x10	11.96	18.5	3.2	33.66	25.4	22.86								
87690-X15	2x07	11.96	18.5	3.2	33.66	17.78	15.24								
87690-X18	2x09	4.95	6.00	4.95	15.90	22.86	20.82								
87690-X19	2x09	8.60	6.00	8.60	23.20	22.86	20.82								
87690-X20	2x10	6.00	14.70	3.30	24.00	25.4	22.86								
87690-X21	2x19	6.00	14.70	3.30	24.00	48.26	45.72								
87690-X22	2x13	10.50	7.75	10.50	28.80	33.02	30.48								
87690-X23	2x14	8.60	6.00	8.60	23.20	35.56	33.02								
87690-X24	2x14	8.95	6.00	8.95	23.9	35.56	33.02								
87690-X25	2x11	3.02	5.08	2.80	12.90	27.94	25.40								
87690-X26	2x05	6.50	52.00	6.50	65.00	12.70	10.16								
87690-X27	2x06	7.15	46.55	7.15	60.85	15.24	12.70								
87690-X28	2x15	7.91	10.00	3.05	20.96	38.10	35.56								
87690-X29	2x10	5.00	20.00	2.50	27.5	25.4	22.86								
87690-X30	2x04	3.09	18.00	2.41	23.50	10.16	7.62								

A

B

C

A

B

C

D

D



Copyright FCJ

mat'l. code		surface <input checked="" type="checkbox"/> ISO 1302		tolerance <input checked="" type="checkbox"/> ISO 406 ISO 1101		projection		product family	
ltr ecn no dr date		tolerances unless otherwise specified		angles linear		mm		BSTIK	
V F-22417 JJU 15.11.05						scale N/A		title	
W F-23090 JCO 16.01.20								HEADER STR,DR	
X F-31897 LMU 18.11.19								DOUBLE BODY POL	
Y F-35412 LMU 19.11.18		dr O. MATHEVON		96.06.07		FCJ		dwg no sheet 2 of - size	
		enr JMC		96.06.07				87690 A3	
T B-19776 AMA 14.12.18		chr JMC		96.06.07				type CUSTOMER Drawing	
U B-21151 AMA 15.06.15		appd JMC		96.06.07					
sheet revision									
index sheet									

A

B

C

D

A

B

C

D

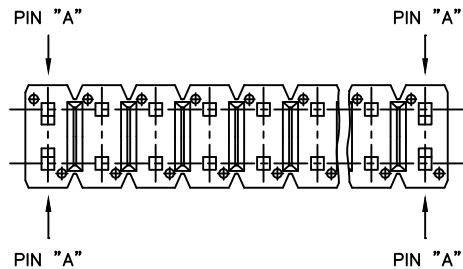
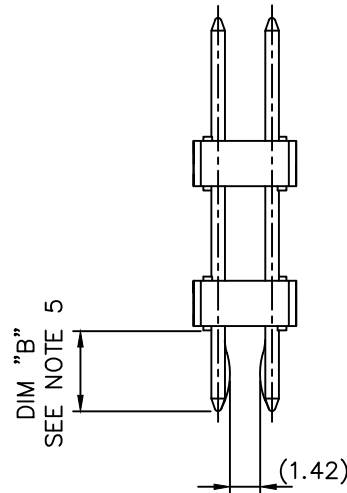
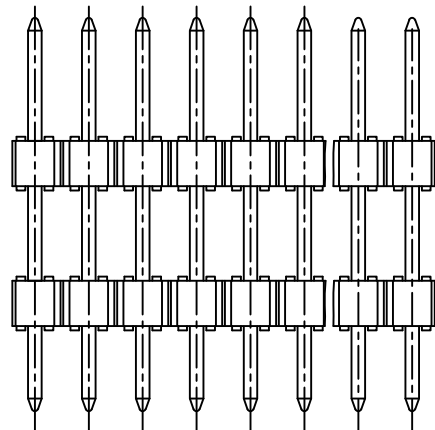

NOTES:

- 1 - PART NUMBER 87690-YXX
- 2 - PINS "A" USED FOR RETENTION.
- 3 - DIRECTION OF RETENTION SHOWN BY ARROWS.
- 4 - KINKED LEGS LOCATION CAN BE MOVED IF A PIN IS MISSING.
- 5 - RETENTION VERSION ONLY AVAILABLE WHEN DIM"B" IS BETWEEN 2.9 mm AND 3.5 mm.
- 6 - 2 AND 3 POSN KINKED HEADER ARE NOT AVAILABLE.

"R" INDICATES A RETENTION HEADER.

mat'l. code		surface		tolerance		projection		product family	
		ISO 1302		ISO 406 ISO 1101		mm		BSTIK	
ltr	ecn no	dr	date	tolerances unless otherwise specified		mm		title	
A	F60421	OMA	96.06.07	angles	linear	scale N/A		HEADER STR,DR DOUBLE BODY POL	
B	70102	JMC	97.01.10					dwg no	
C	F70179	JMC	97.03.28					sheet 3 of - size	
D	F70815	OMA	97.12.23	dr	O. MATHEVON	96.06.07	87690		A3
E	F80321	JMC	98.05.04	enr	JMC	96.06.07	type		CUSTOMER Drawing
F	F05-029	JCO	05.11.14	chr	JMC	96.06.07			
G	F06-0196	LMU	06.06.20	appd	JMC	96.06.07			
sheet	revision								
index	sheet								



Copyright FCJ