

**OPA3680**

For most current data sheet and other product information, visit [www.burr-brown.com](http://www.burr-brown.com)

# *SpeedPlus™* Triple, Wideband, Voltage-Feedback OPERATIONAL AMPLIFIER With Disable

## FEATURES

- WIDEBAND +5V OPERATION: 220MHz (G = +2)
- HIGH OUTPUT CURRENT: 150mA
- OUTPUT VOLTAGE SWING:  $\pm 4.0V$
- HIGH SLEW RATE: 1800V/ $\mu s$
- LOW SUPPLY CURRENT: 6.4mA/ch
- LOW DISABLED CURRENT: 300 $\mu A$ /ch
- ENABLE/DISABLE TIME: 25ns/100ns

## APPLICATIONS

- VIDEO LINE DRIVING
- xDSL LINE DRIVER
- HIGH-SPEED IMAGING CHANNELS
- ADC BUFFERS
- PORTABLE INSTRUMENTS
- TRANSIMPEDANCE AMPLIFIERS
- ACTIVE FILTERS

## DESCRIPTION

The OPA3680 represents a major step forward in unity gain stable, voltage-feedback op amps. A new internal architecture provides slew rate and full power bandwidth previously found only in wideband current-feedback op amps. A new output stage architecture delivers high currents with a minimal headroom requirement. These give exceptional single-supply operation. Using a single +5V supply, the OPA3680 can deliver a 1V to 4V output swing with over 80mA drive current and 150MHz bandwidth. This combination of features makes the OPA3680 an ideal RGB line driver or single-supply ADC input driver.

The OPA3680's low 6.4mA/ch supply current is precisely trimmed at 25°C. This trim, along with low temperature drift, guarantees lower maximum supply

current than competing products. System power may be reduced further using the optional disable control pin. Leaving this disable pin open, or holding it high, will operate the OPA3680 normal. If pulled low, the OPA3680 supply current drops to less than 300 $\mu A$ /ch while the output goes into a high impedance state. This feature may be used for either power savings or to implement video MUX applications.

## OPA3680 RELATED PRODUCTS

	SINGLES	DUALS	TRIPLES
Voltage Feedback	OPA680	OPA2680	OPA3680
Current Feedback	OPA681	OPA2681	OPA3681
Fixed Gain	OPA682	OPA2682	OPA3682

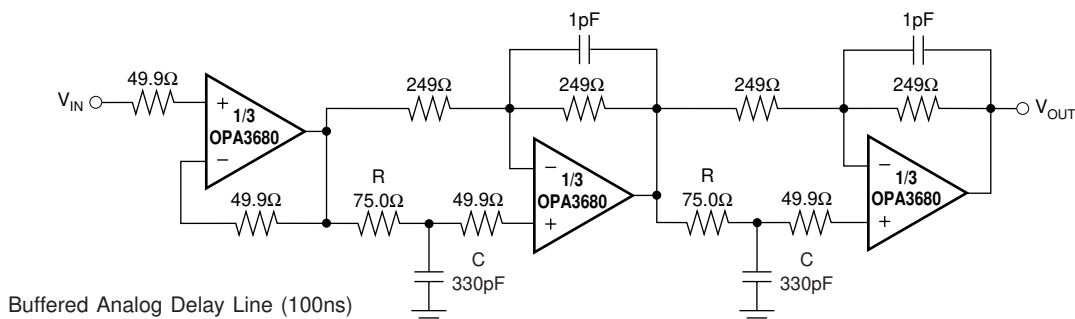

International Airport Industrial Park • Mailing Address: PO Box 11400, Tucson, AZ 85734 • Street Address: 6730 S. Tucson Blvd., Tucson, AZ 85706 • Tel: (520) 746-1111  
 Twx: 910-952-1111 • Internet: <http://www.burr-brown.com/> • Cable: BBRCORP • Telex: 066-6491 • FAX: (520) 889-1510 • Immediate Product Info: (800) 548-6132

# SPECIFICATIONS: $V_S = \pm 5V$

$R_F = 250\Omega$ ,  $R_L = 100\Omega$ , and  $G = +2$ , (Figure 1 for AC performance only),  $R_F = 25\Omega$  for  $G = +1$ , unless otherwise noted.

PARAMETER	CONDITIONS	OPA3680E, U						TEST LEVEL <sup>(1)</sup>
		TYP	GUARANTEED				MIN/ MAX	
		+25°C	+25°C <sup>(2)</sup>	0°C to 70°C <sup>(3)</sup>	-40°C to +85°C <sup>(3)</sup>	UNITS		
<b>AC PERFORMANCE (Figure 1)</b>								
Small-Signal Bandwidth	$G = +1$ , $V_O = 0.5V_{p-p}$ , $R_F = 25\Omega$	400				MHz	typ	C
	$G = +2$ , $V_O = 0.5V_{p-p}$	220	210	200	190	MHz	min	B
	$G = +10$ , $V_O = 0.5V_{p-p}$	30	20	20	20	MHz	min	B
Gain Bandwidth Product	$G \geq 10$	300	200	200	200	MHz	min	B
Bandwidth for 0.1dB Gain Flatness	$G = +2$ , $V_O < 0.5V_{p-p}$	30				MHz	typ	C
Peaking at a Gain of +1	$V_O < 0.5V_{p-p}$	4				dB	typ	C
Large-Signal Bandwidth	$G = +2$ , $V_O = 5V_{p-p}$	175				MHz	typ	C
Slew Rate	$G = +2$ , 4V Step	1800	1400	1200	900	V/ $\mu$ s	min	B
Rise/Fall Time	$G = +2$ , $V_O = 0.5V$ Step	1.4				ns	max	B
	$G = +2$ , $V_O = 4V$ Step	2.8				ns	max	B
Settling Time to 0.02%	$G = +2$ , $V_O = 0 \geq 2V$ Step	12				ns	typ	C
0.1%	$G = +2$ , $V_O = 0 \geq 2V$ Step	8				ns	typ	C
Harmonic Distortion	$G = +2$ , $f = 5MHz$ , $V_O = 2V_{p-p}$							
2nd Harmonic	$R_L = 100\Omega$	-80				dBc	typ	C
	$R_L \geq 500\Omega$	-90				dBc	typ	C
3rd Harmonic	$R_L = 100\Omega$	-77				dBc	typ	C
	$R_L \geq 500\Omega$	-90				dBc	typ	C
Crosstalk	Input Referred, $f = 5MHz$ , All Hostile	-58				dBc	typ	C
Input Voltage Noise	$f > 1MHz$	4.8	5.3	5.9	6.1	nV/ $\sqrt{Hz}$	max	B
Input Current Noise	$f > 1MHz$	2.5	2.8	3.0	3.6	pA/ $\sqrt{Hz}$	max	B
Differential Gain	$G = +2$ , NTSC, $V_O = 1.4V_{p-p}$ , $R_L = 150$	0.05				%	typ	C
Differential Phase	$G = +2$ , NTSC, $V_O = 1.4V_{p-p}$ , $R_L = 150$	0.03				deg	typ	C
<b>DC PERFORMANCE<sup>(4)</sup></b>								
Open-Loop Voltage Gain ( $A_{OL}$ )	$V_O = 0V$ , $R_L = 100\Omega$	58	<b>54</b>	52	50	dB	min	A
Input Offset Voltage	$V_{CM} = 0V$	$\pm 1.0$	<b><math>\pm 5.0</math></b>	$\pm 5.5$	$\pm 6.5$	mV	max	A
Average Offset Voltage Drift	$V_{CM} = 0V$			$\pm 10$	$\pm 10$	$\mu V/^\circ C$	max	B
Input Bias Current	$V_{CM} = 0V$	+8	<b>+15</b>	+20	+35	$\mu A$	max	A
Average Bias Current Drift (magnitude)	$V_{CM} = 0V$			-70	-150	nA/ $^\circ C$	max	B
Input Offset Current	$V_{CM} = 0V$	$\pm 0.1$	<b><math>\pm 0.8</math></b>	$\pm 1.2$	$\pm 1.5$	$\mu A$	max	A
Average Offset Current Drift	$V_{CM} = 0V$			$\pm 1$	$\pm 1.5$	nA/ $^\circ C$	max	B
<b>INPUT</b>								
Common-Mode Input Range (CMIR) <sup>(5)</sup>	$V_{CM} = \pm 1.0V$	$\pm 3.5$	<b><math>\pm 3.4</math></b>	$\pm 3.3$	$\pm 3.2$	V	min	A
Common-Mode Rejection Ratio (CMRR)	$V_{CM} = \pm 1.0V$	59	<b>56</b>	53	53	dB	min	A
Input Impedance								
Differential-Mode		190    0.6				k $\Omega$    pF	typ	C
Common-Mode		3.2    0.9				M $\Omega$    pF	typ	C
<b>OUTPUT</b>								
Voltage Output Swing	No Load	$\pm 4.0$	<b><math>\pm 3.8</math></b>	$\pm 3.7$	$\pm 3.6$	V	min	A
	100 $\Omega$ Load	$\pm 3.9$	<b><math>\pm 3.7</math></b>	$\pm 3.6$	$\pm 3.3$	V	min	A
Current Output, Sourcing	$V_O = 0$	+190	<b>+160</b>	+140	+80	mA	min	A
Current Output, Sinking	$V_O = 0$	-150	<b>-135</b>	-130	-80	mA	min	A
Closed-Loop Output Impedance	$G = +2$ , $f = 100kHz$	0.03				$\Omega$	typ	C
<b>DISABLE</b>								
Power-Down Supply Current (+ $V_S$ )	Disable Low	-300				$\mu A$	typ	C
Disable Time	$V_{DIS} = 0V$ , Each Channel	100				ns	typ	C
Enable Time		25				ns	typ	C
Off Isolation	$G = +2$ , 5MHz	70				dB	typ	C
Output Capacitance in Disable		4				pF	typ	C
Turn On Glitch	$G = +2$ , $R_L = 150\Omega$	$\pm 50$				mV	typ	C
Turn Off Glitch	$G = +2$ , $R_L = 150\Omega$	$\pm 20$				mV	typ	C
Enable Voltage		3.3	<b>3.5</b>	3.6	3.7	V	min	A
Disable Voltage		1.8	<b>1.7</b>	1.6	1.5	V	max	A
Control Pin Input Bias Current	$V_{DIS} = 0V$	100	<b>160</b>	160	160	$\mu A$	max	A
<b>POWER SUPPLY</b>								
Specified Operating Voltage		$\pm 5$				V	typ	C
Maximum Operating Voltage Range			<b><math>\pm 6</math></b>	$\pm 6$	$\pm 6$	V	max	A
Max Quiescent Current	$V_S = \pm 5V$ , Each Channel	6.4	<b>6.8</b>	7.0	7.2	mA	max	A
Min Quiescent Current	$V_S = \pm 5V$ , Each Channel	6.4	<b>6.0</b>	6.0	5.3	mA	min	A
Power Supply Rejection Ratio (+PSRR)	Input Referred	65	<b>60</b>	58	58	dB	min	A
<b>THERMAL CHARACTERISTICS</b>								
Specified Operating Range U, E Package		-40 to +85				$^\circ C$	typ	C
Thermal Resistance, $\theta_{JA}$								
U SO-16		100				$^\circ C/W$	typ	C
E SSOP-16		100				$^\circ C/W$	typ	C

NOTES: (1) Test Levels: (A) 100% tested at 25°C. Over temperature limits by characterization and simulation. (B) Limits set by characterization and simulation. (C) Typical value only for information. (2) Junction temperature = ambient for 25°C guaranteed specifications. (3) Junction temperature = ambient at low temperature limit; junction temperature = Ambient +23°C at high temperature limit for over temperature guaranteed specifications. (4) Current is considered positive out-of-node.  $V_{CM}$  is the input common-mode voltage. (5) Tested < 3dB below minimum CMR specification at  $\pm$ CMIR limits.

# SPECIFICATIONS: $V_S = +5V$

$R_F = 250\Omega$ ,  $R_L = 100\Omega$  to  $V_S/2$ ,  $G = +2$ , (Figure 2 for AC performance only),  $R_F = 25\Omega$  for  $G = +1$ , unless otherwise noted.

PARAMETER	CONDITIONS	OPA3680E, U						TEST LEVEL <sup>(1)</sup>
		TYP	GUARANTEED				MIN/ MAX	
		+25°C	+25°C <sup>(2)</sup>	0°C to 70°C <sup>(3)</sup>	-40°C to +85°C <sup>(3)</sup>	UNITS		
<b>AC PERFORMANCE (Figure 2)</b>								
Small-Signal Bandwidth	$G = +1, V_O < 0.5V_{p-p}$	300				MHz	typ	C
	$G = +2, V_O < 0.5V_{p-p}$	220	160	160	140	MHz	min	B
	$G = +10, V_O < 0.5V_{p-p}$	25	20	19	18	MHz	min	C
Gain Bandwidth Product	$G \geq 10$	250	200	190	180	MHz	min	B
Bandwidth for 0.1dB Gain Flatness	$G = +2, V_O < 0.5V_{p-p}$	20				MHz	typ	C
Peaking at a Gain of +1	$V_O < 0.5V_{p-p}$	5				dB	typ	C
Large-Signal Bandwidth	$G = +2, V_O = 2V_{p-p}$	175				MHz	typ	C
Slew Rate	$G = +2, 2V$ Step	1000	700	670	550	V/ $\mu$ s	min	B
Rise Time	$G = +2, V_O = 0.5V$ Step	1.6				ns	typ	C
Fall Time	$G = +2, V_O = 2V$ Step	2.0				ns	typ	C
Settling Time to 0.02%	$G = +2, V_O = 2V$ Step	12				ns	typ	C
0.1%	$G = +2, V_O = 2V$ Step	8				ns	typ	C
Harmonic Distortion	$G = +2, f = 5MHz, V_O = 2V_{p-p}$							
2nd Harmonic	$R_L = 100\Omega$	-70				dBc	typ	C
	$R_L \geq 500\Omega$	-80				dBc	typ	C
3rd Harmonic	$R_L = 100\Omega$	-71				dBc	typ	C
	$R_L \geq 500\Omega$	-84				dBc	typ	C
Input Voltage Noise	$f > 1MHz$	5	5.5	6	6.2	nV/ $\sqrt{Hz}$	max	B
Input Current Noise	$f > 1MHz$	2.5	3	3.5	3.4	pA/ $\sqrt{Hz}$	max	B
Differential Gain	$G = +2, NTSC, V_O = 1.4V_{p-p}, R_L = 150$ to $V_S/2$	0.06				%	typ	C
Differential Phase	$G = +2, NTSC, V_O = 1.4V_{p-p}, R_L = 150$ to $V_S/2$	0.03				deg	typ	C
<b>DC PERFORMANCE<sup>(4)</sup></b>								
Open-Loop Voltage Gain ( $A_{OL}$ )	$V_O = 0V, R_L = 100\Omega$	58	<b>54</b>	52	50	dB	min	A
Input Offset Voltage	$V_{CM} = 2.5V$	$\pm 1.0$	<b><math>\pm 6.5</math></b>	$\pm 7.5$	$\pm 9.0$	mV	max	A
Average Offset Voltage Drift	$V_{CM} = 2.5V$			-10	-12	$\mu V/^\circ C$	max	B
Input Bias Current	$V_{CM} = 2.5V$	+8	<b>+16</b>	+21	+37	$\mu A$	max	A
Average Bias Current Drift (magnitude)	$V_{CM} = 2.5V$			-52	-80	nA/ $^\circ C$	max	B
Input Offset Current	$V_{CM} = 2.5V$	$\pm 0.1$	<b><math>\pm 0.7</math></b>	$\pm 1.0$	$\pm 1.2$	$\mu A$	max	A
Average Offset Current Drift	$V_{CM} = 2.5V$			$\pm 0.5$	$\pm 1.0$	nA/ $^\circ C$	max	B
<b>INPUT</b>								
Least Positive Input Voltage <sup>(5)</sup>		1.5	<b>1.6</b>	1.7	1.8	V	min	A
Most Positive Input Voltage <sup>(5)</sup>		3.5	<b>3.4</b>	3.3	3.2	V	max	A
Common-Mode Rejection Ratio (CMRR)	$V_{CM} = 2.5V$	59	<b>56</b>	53	52	dB	min	A
Input Impedance								
Differential-Mode		92    1.4				k $\Omega$    pF	typ	C
Common-Mode		2.2    1.5				M $\Omega$    pF	typ	C
<b>OUTPUT</b>								
Most Positive Output Voltage	No Load	4	<b>3.8</b>	3.6	3.5	V	min	A
	$R_L = 100\Omega, 2.5V$	3.9	<b>3.7</b>	3.5	3.4	V	min	A
Least Positive Output Voltage	No Load	1	<b>1.2</b>	1.4	1.5	V	min	A
	$R_L = 100\Omega, 2.5V$	1.1	<b>1.3</b>	1.5	1.7	V	min	A
Current Output, Sourcing		+150	<b>+110</b>	+110	+60	mA	min	A
Current Output, Sinking		-110	<b>-80</b>	-70	-50	mA	min	A
Closed-Loop Output Impedance	$G = +2, f = 100kHz$	0.03					typ	C
<b>DISABLE</b>								
Power-Down Supply Current (+ $V_S$ )	Disable Low $V_{DIS} = 0V$ , Each Channel	-250				$\mu A$	typ	C
Disable Time		100				ns	typ	C
Enable Time		25				ns	typ	C
Off Isolation	$G = +2, 5MHz$	65				dB	typ	C
Output Capacitance in Disable		4				pF	typ	C
Turn On Glitch	$G = +2, R_L = 150\Omega, V_{IN} = V_S/2$	$\pm 50$				mV	typ	C
Turn Off Glitch	$G = +2, R_{LP} = 150\Omega, V_{IN} = V_S/2$	$\pm 20$				mV	typ	C
Enable Voltage		3.3	<b>3.5</b>	3.6	3.7	V	min	A
Disable Voltage		1.8	<b>1.7</b>	1.6	1.5	V	max	A
Control Pin Input Bias Current	$V_{DIS} = 0V$	100				$\mu A$	typ	C
<b>POWER SUPPLY</b>								
Specified Single Supply Operating Voltage		5				V	typ	C
Maximum Single Supply Operating Voltage			<b>12</b>	12	12	V	max	A
Max Quiescent Current	$V_S = +5V$ , Each Channel	5.1	<b>6.0</b>	6.0	6.0	mA	max	A
Min Quiescent Current	$V_S = +5V$ , Each Channel	5.1	<b>4.0</b>	4.0	3.8	mA	min	A
Power Supply Rejection Ratio (+PSRR)	Input Referred	55				dB	typ	C
<b>TEMPERATURE RANGE</b>								
Specification: U, E		-40 to +85				$^\circ C$	typ	C
Thermal Resistance, $\theta_{JA}$								
U SO-16		100				$^\circ C/W$	typ	C
E SSOP-16		100				$^\circ C/W$	typ	C

NOTES: (1) Test Levels: (A) 100% tested at 25°C. Over temperature limits by characterization and simulation. (B) Limits set by characterization and simulation. (C) Typical value only for information. (2) Junction temperature = ambient for 25°C guaranteed specifications. (3) Junction temperature = ambient at low temperature limit; junction temperature = ambient +23°C at high temperature limit for over temperature guaranteed specifications. (4) Current is considered positive out-of-node.  $V_{CM}$  is the input common-mode voltage. (5) Tested < 3dB below minimum CMR specification at  $\pm$ CMIR limits.

## ABSOLUTE MAXIMUM RATINGS

Power Supply .....	$\pm 6.5V_{DC}$
Internal Power Dissipation .....	See Thermal Information
Differential Input Voltage .....	$\pm 1.2V$
Input Voltage Range .....	$\pm V_S$
Storage Temperature Range: U, E .....	$-40^{\circ}C$ to $+125^{\circ}C$
Lead Temperature (soldering, 10s) .....	$+300^{\circ}C$
Junction Temperature ( $T_J$ ) .....	$+175^{\circ}C$



## ELECTROSTATIC DISCHARGE SENSITIVITY

Electrostatic discharge can cause damage ranging from performance degradation to complete device failure. Burr-Brown Corporation recommends that all integrated circuits be handled and stored using appropriate ESD protection methods.

ESD damage can range from subtle performance degradation to complete device failure. Precision integrated circuits may be more susceptible to damage because very small parametric changes could cause the device not to meet published specifications.

## PIN CONFIGURATION

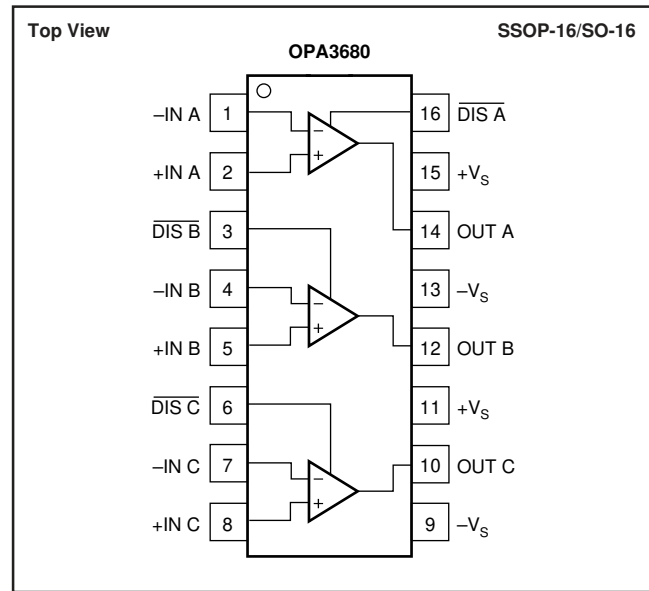

## PACKAGE/ORDERING INFORMATION

PRODUCT	PACKAGE	PACKAGE DRAWING NUMBER	TEMPERATURE RANGE	PACKAGE MARKING	ORDERING NUMBER <sup>(1)</sup>	TRANSPORT MEDIA
OPA3680E	SSOP-16 Surface Mount	322	$-40^{\circ}C$ to $+85^{\circ}C$	OPA3680E	OPA3680E/250	Tape and Reel
"	"	"	"	"	OPA3680E/2K5	Tape and Reel
OPA3680U	SO-16 Surface Mount	265	$-40^{\circ}C$ to $+85^{\circ}C$	OPA3680U	OPA3680U	Rails
"	"	"	"	"	OPA3680U/2K5	Tape and Reel

NOTE: (1) Models with a slash (/) are available only in Tape and Reel in the quantities indicated (e.g., /2K5 indicates 2500 devices per reel). Ordering 2500 pieces of "OPA3680E/2K5" will get a single 2500-piece Tape and Reel.

The information provided herein is believed to be reliable; however, BURR-BROWN assumes no responsibility for inaccuracies or omissions. BURR-BROWN assumes no responsibility for the use of this information, and all use of such information shall be entirely at the user's own risk. Prices and specifications are subject to change without notice. No patent rights or licenses to any of the circuits described herein are implied or granted to any third party. BURR-BROWN does not authorize or warrant any BURR-BROWN product for use in life support devices and/or systems.

# TYPICAL PERFORMANCE CURVES: $V_S = \pm 5V$

At  $T_A = +25^\circ C$ ,  $G = +2$ ,  $R_F = 250\Omega$ , and  $R_L = 100\Omega$ , unless otherwise noted. See Figure 1.

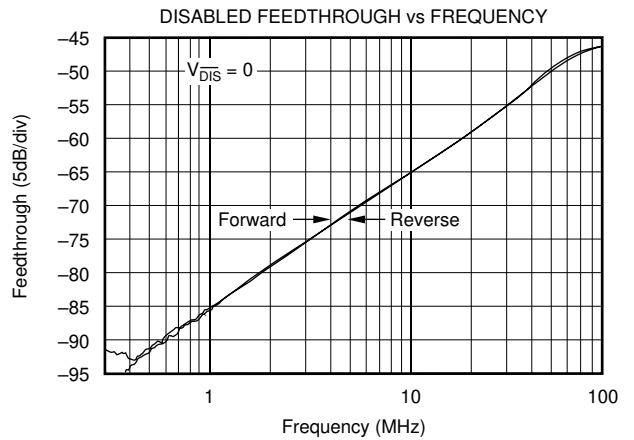
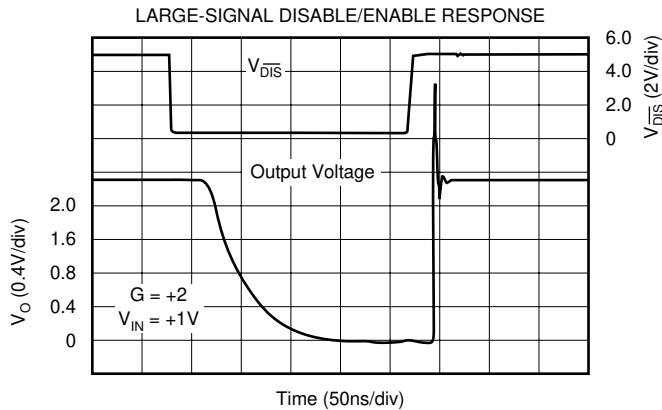
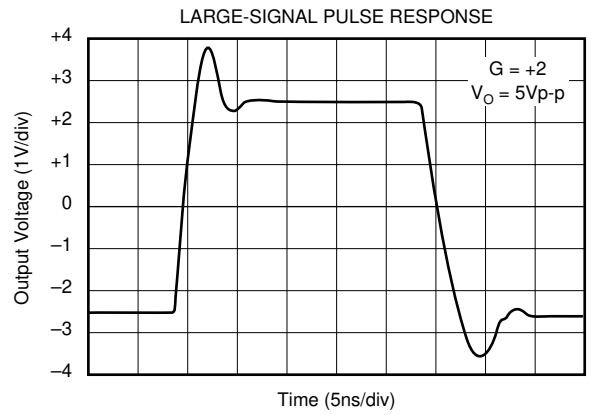
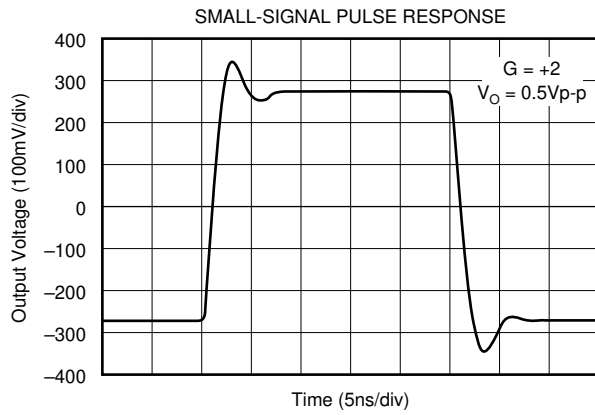
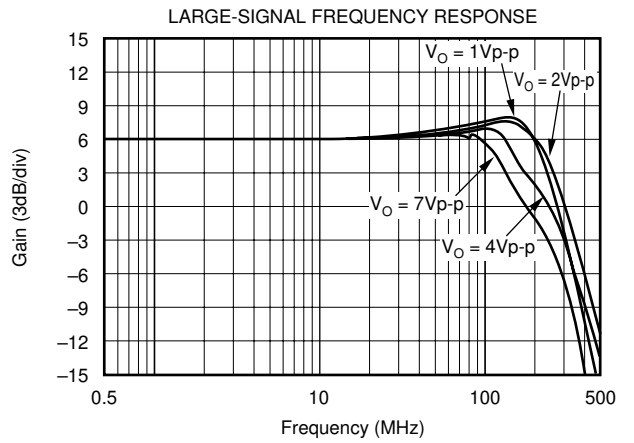
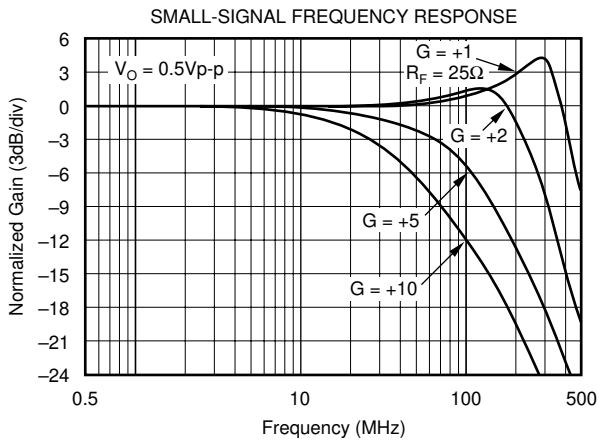

# TYPICAL PERFORMANCE CURVES: $V_S = \pm 5V$ (Cont.)

At  $T_A = +25^\circ C$ ,  $G = +2$ ,  $R_F = 250\Omega$ , and  $R_L = 100\Omega$ , unless otherwise noted. See Figure 1.

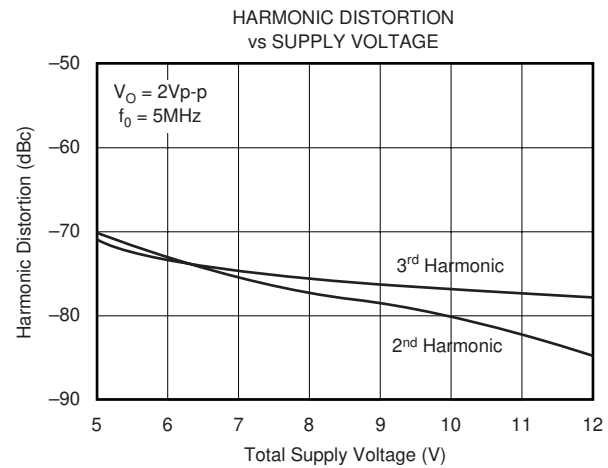
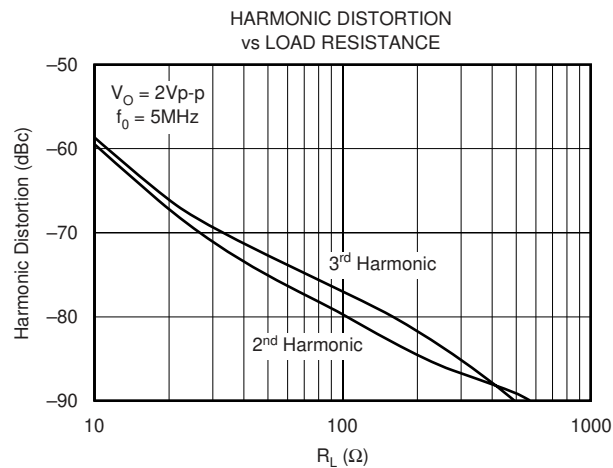
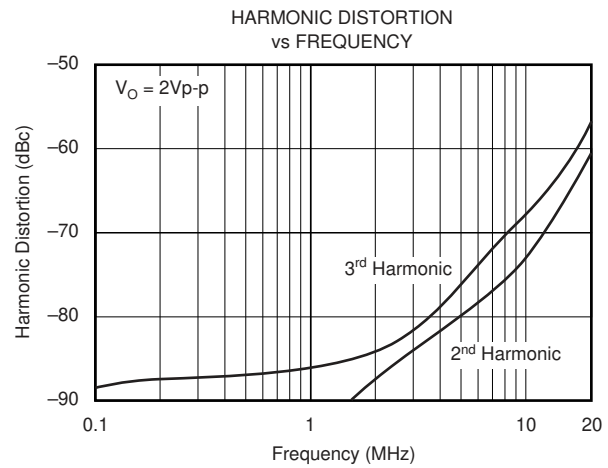
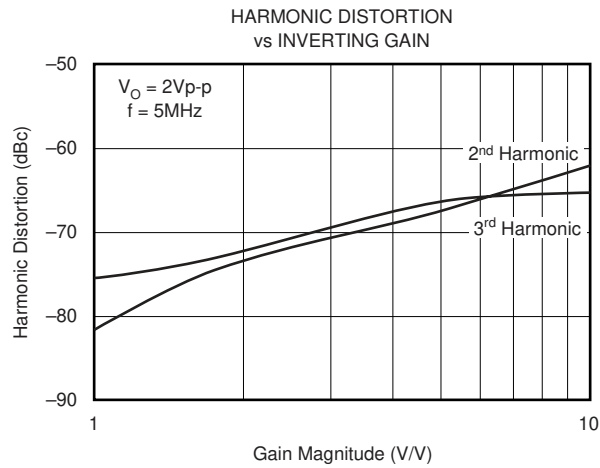
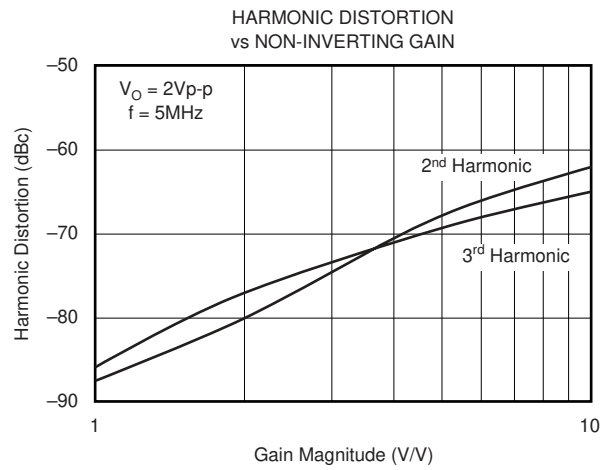
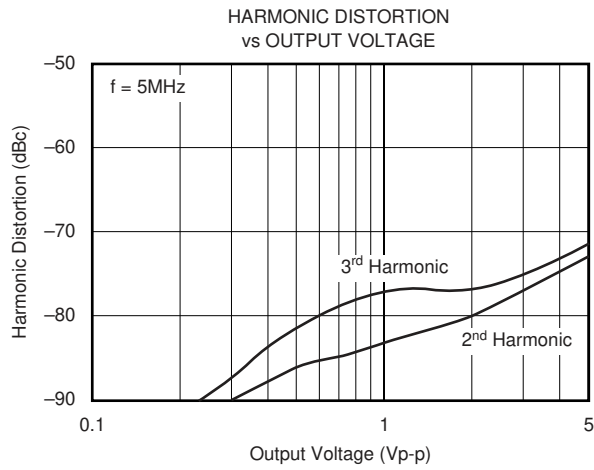

# TYPICAL PERFORMANCE CURVES: $V_S = \pm 5V$

At  $T_A = +25^\circ C$ ,  $G = +2$ ,  $R_F = 250\Omega$ , and  $R_L = 100\Omega$ , unless otherwise noted. See Figure 1.

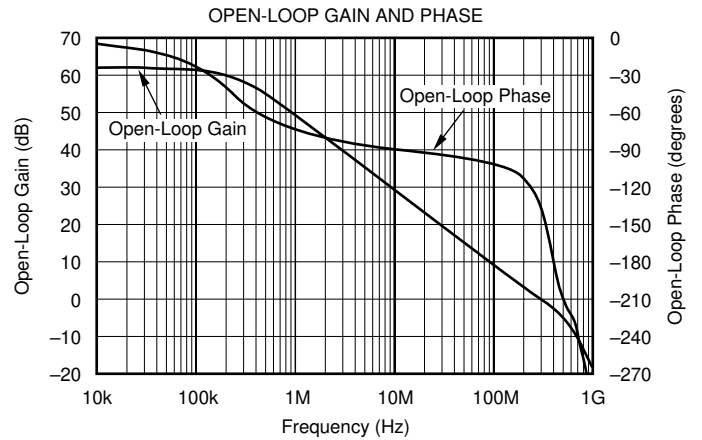
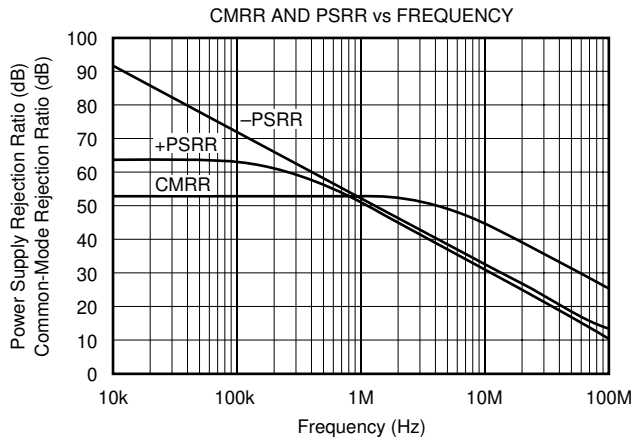
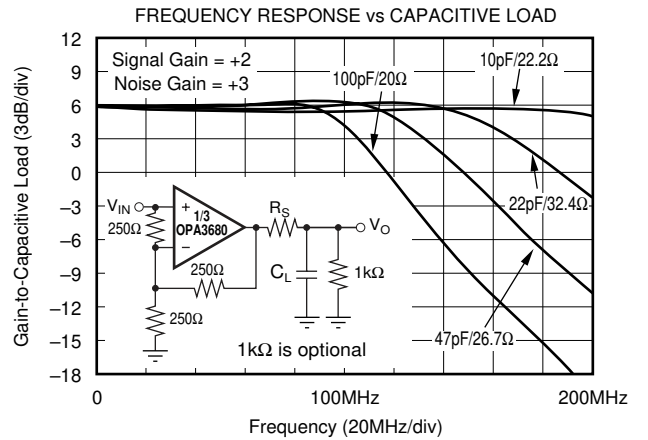
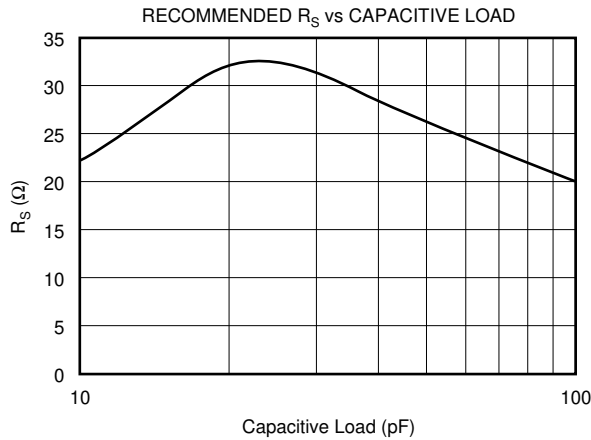
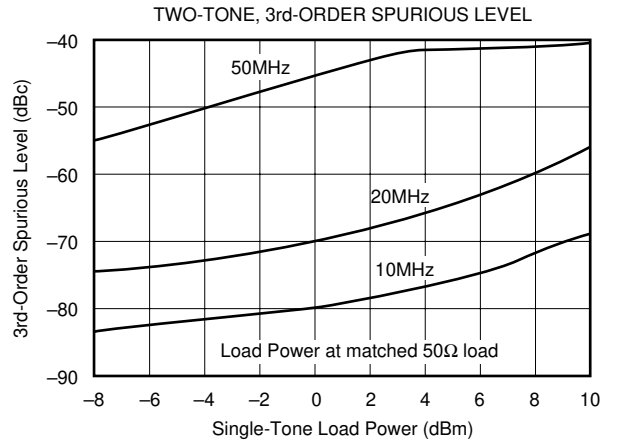
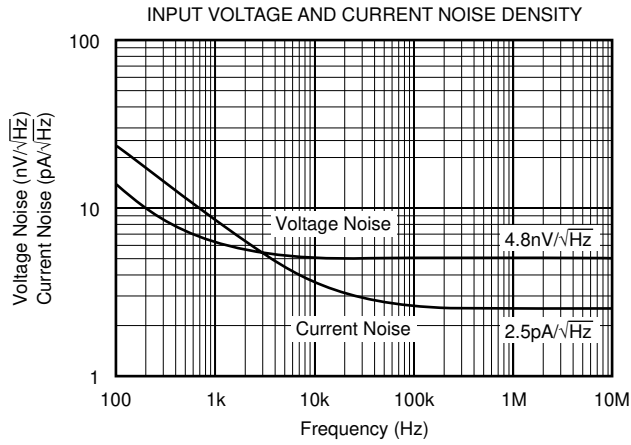

# TYPICAL PERFORMANCE CURVES: $V_S = \pm 5V$ (Cont.)

At  $T_A = +25^\circ C$ ,  $G = +2$ ,  $R_F = 250\Omega$ , and  $R_L = 100\Omega$ , unless otherwise noted. See Figure 1.

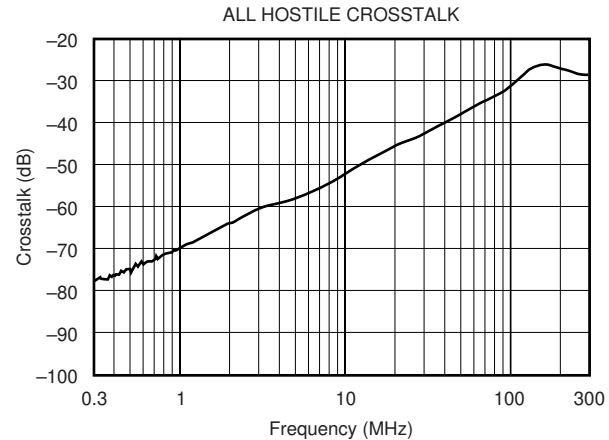
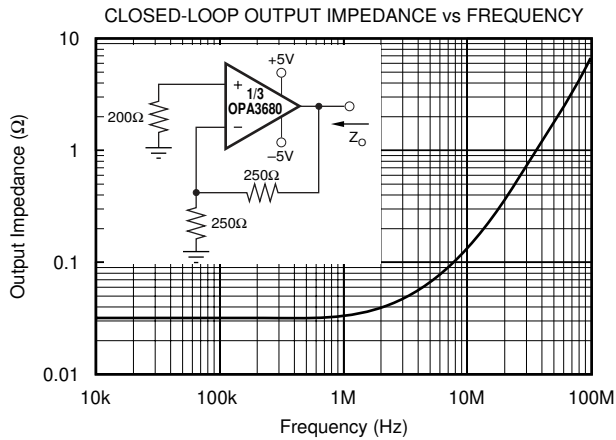
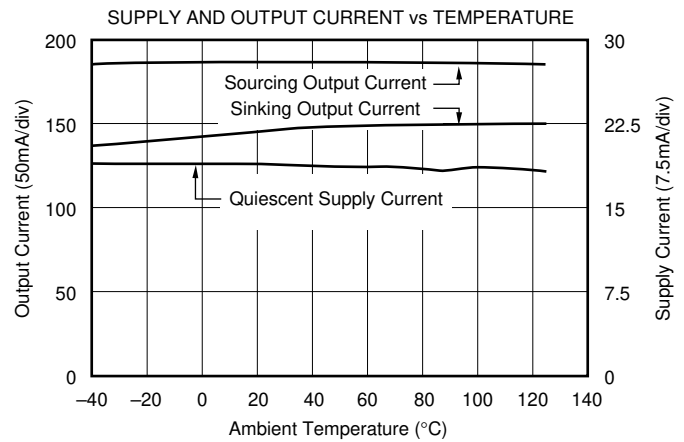
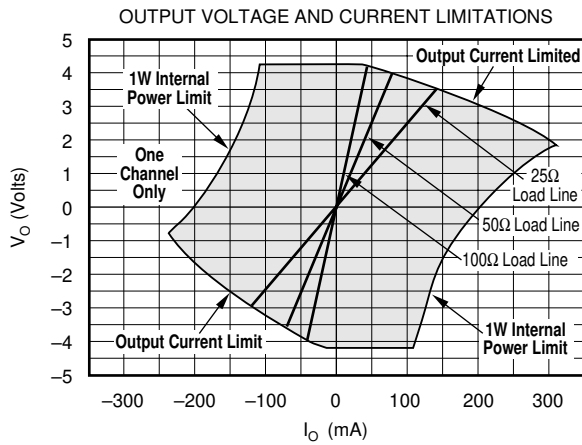
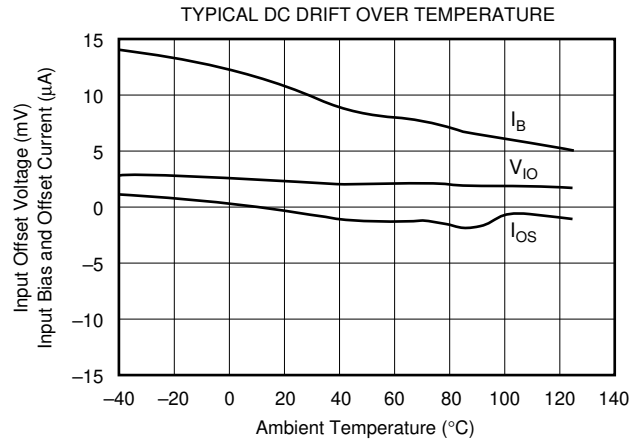
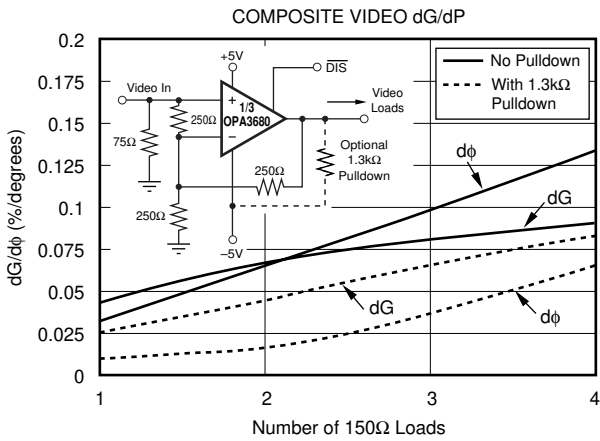



# TYPICAL PERFORMANCE CURVES: $V_S = +5V$

At  $T_A = +25^\circ C$ ,  $G = +2$ ,  $R_F = 250\Omega$ , and  $R_L = 100\Omega$  to  $V_S/2$ , unless otherwise noted. See Figure 2.

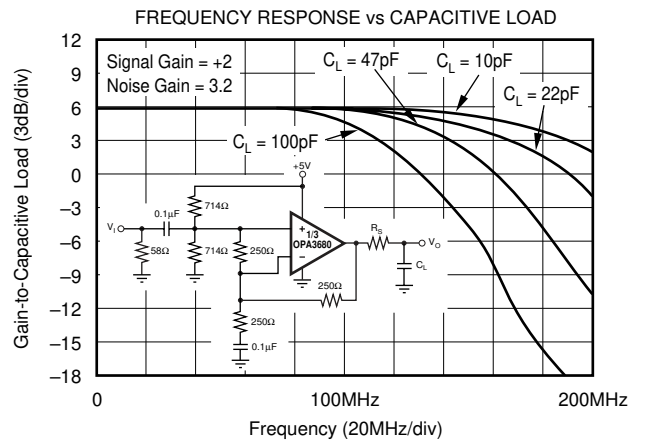
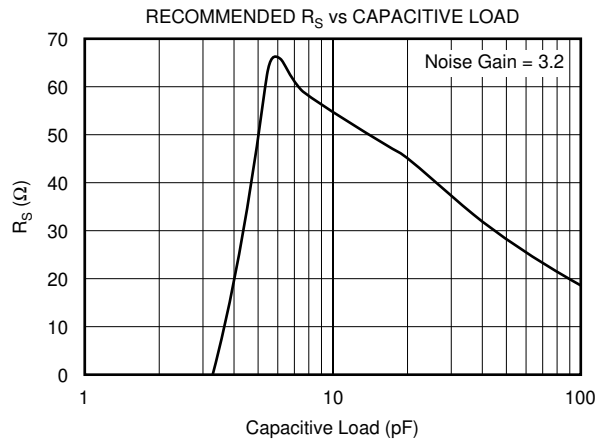
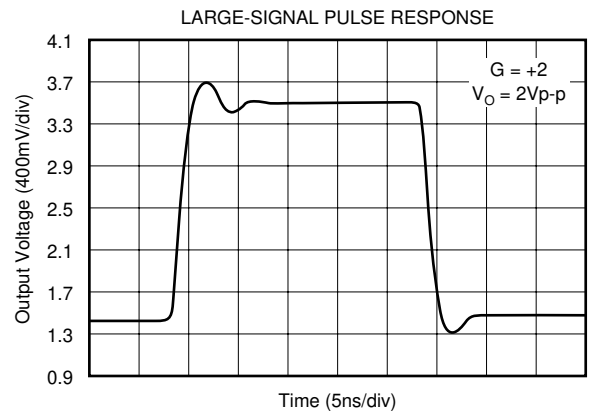
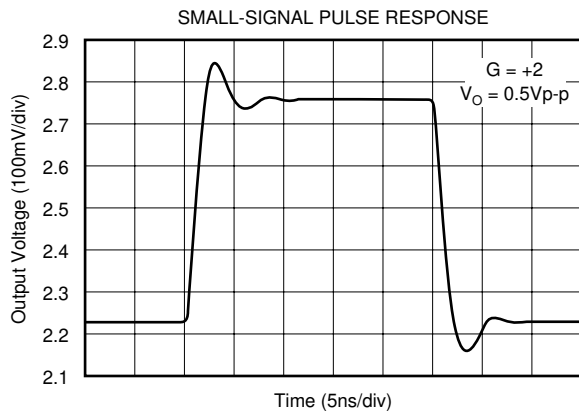
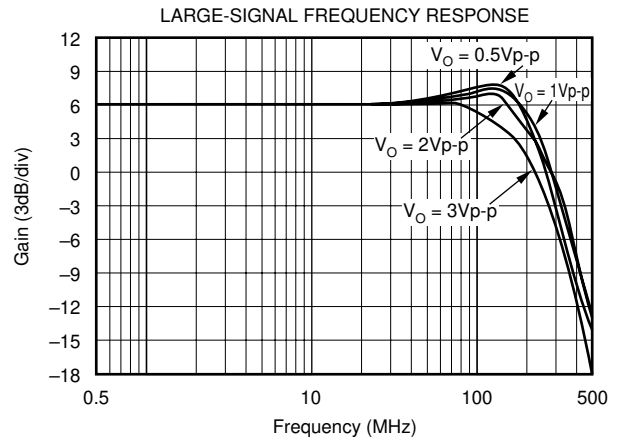
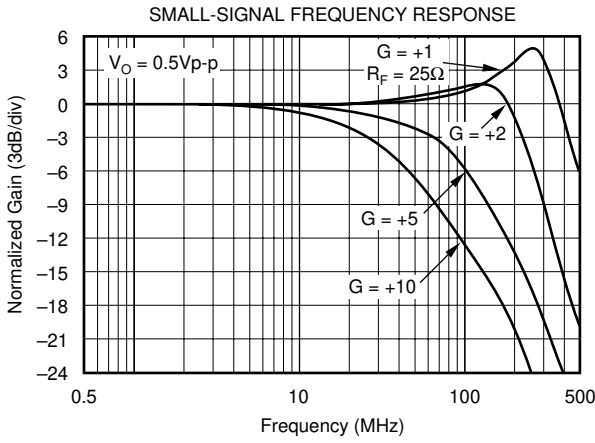

# TYPICAL PERFORMANCE CURVES: $V_S = +5V$ (Cont.)

At  $T_A = +25^\circ C$ ,  $G = +2$ ,  $R_F = 402\Omega$ , and  $R_L = 100\Omega$  to  $V_S/2$ , unless otherwise noted. See Figure 2.

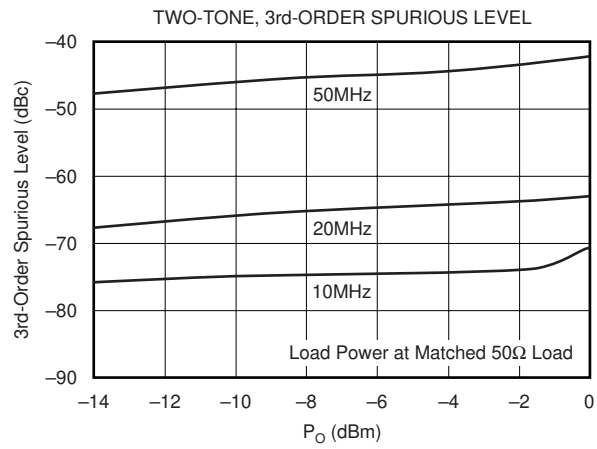

# APPLICATIONS INFORMATION

## WIDEBAND VOLTAGE FEEDBACK OPERATION

The OPA3680 provides an exceptional combination of high output power capability with a wideband, unity gain stable voltage feedback op amp using a new high slew rate input stage. Typical differential input stages used for voltage feedback op amps are designed to steer a fixed-bias current to the compensation capacitor, setting a limit to the achievable slew rate. The OPA3680 uses a new input stage which places the transconductance element between two input buffers, using their output currents as the forward signal. As the error voltage increases across the two inputs, an increasing current is delivered to the compensation capacitor. This provides very high slew rate (1800V/ $\mu$ s) while consuming relatively low quiescent current (6.4mA). This exceptional full power performance comes at the price of a slightly higher input noise voltage than alternative architectures. The 4.8nV/ $\sqrt{\text{Hz}}$  input voltage noise for the OPA3680 is exceptionally low for this type of input stage.

Figure 1 shows the DC-coupled, gain of +2, dual power supply circuit configuration used as the basis of the  $\pm 5\text{V}$  Specifications and Typical Performance Curves. For test purposes, the input impedance is set to  $50\Omega$  with a resistor to ground and the output impedance is set to  $50\Omega$  with a series output resistor. Voltage swings reported in the specifications are taken directly at the input and output pins, while output powers (dBm) are at the matched  $50\Omega$  load. For the circuit of Figure 1, the total effective load will be  $100\Omega \parallel 498\Omega$ . The disable control line is typically left open to guarantee normal amplifier operation. Two optional components are included in Figure 1. An additional resistor ( $100\Omega$ ) is included in series with the non-inverting input. Combined with the  $25\Omega$  DC source resistance looking back towards the signal generator, this gives an input bias current cancelling resistance that

matches the  $125\Omega$  source resistance seen at the inverting input (see the DC Accuracy and Offset Control section). In addition to the usual power supply decoupling capacitors to ground, a  $0.1\mu\text{F}$  capacitor is included between the two power supply pins. In practical PC board layouts, this optional-added capacitor will typically improve the 2nd harmonic distortion performance by 3dB to 6dB.

Figure 2 shows the AC-coupled, gain of +2, single supply circuit configuration which is the basis of the +5V Specifications and Typical Performance Curves. Though not a “rail-to-rail” design, the OPA3680 requires minimal input and output voltage headroom compared to other very wideband voltage feedback op amps. It will deliver a 3Vp-p output swing on a single +5V supply with  $>150\text{MHz}$  bandwidth. The key requirement of broadband single-supply operation is to maintain input and output signal swings within the useable voltage ranges at both the input and the output. The circuit of Figure 2 establishes an input midpoint bias using a simple resistive divider from the +5V supply (two  $402\Omega$  resistors). The input signal is then AC-coupled into the midpoint voltage bias. The input voltage can swing to within 1.5V of either supply pin, giving a 2Vp-p input signal range centered between the supply pins. The input impedance matching resistor ( $68\Omega$ ) used for testing is adjusted to give a  $50\Omega$  input load when the parallel combination of the biasing divider network is included. Again, an additional resistor ( $50\Omega$  in this case) is included directly in series with the non-inverting input. This minimum recommended value provides part of the DC source resistance matching for the non-inverting input bias current. It is also used to form a simple parasitic pole to roll off the frequency response at very high frequencies ( $>500\text{MHz}$ ) using the input parasitic capacitance to form a bandlimiting pole. The gain resistor ( $R_G$ ) is AC-coupled, giving the circuit a DC gain of +1, which puts the input DC bias voltage (2.5V) at the output as well. The

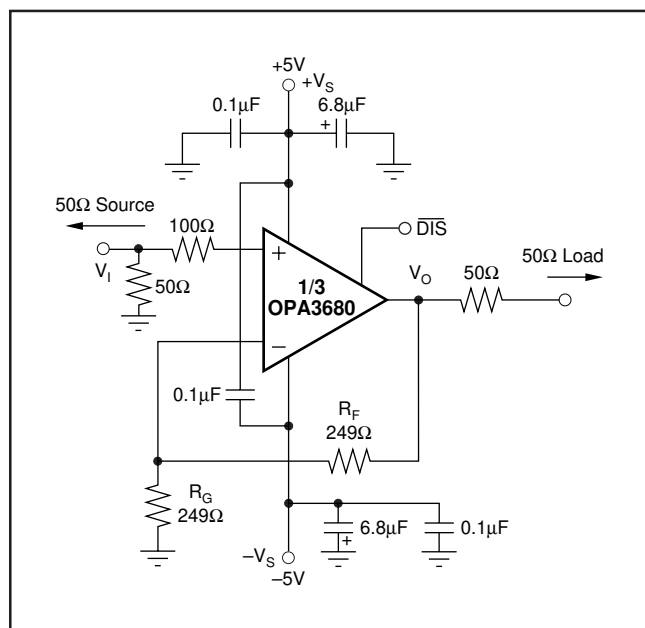

FIGURE 1. DC-Coupled,  $G = +2$ , Bipolar Supply, Specification and Test Circuit.

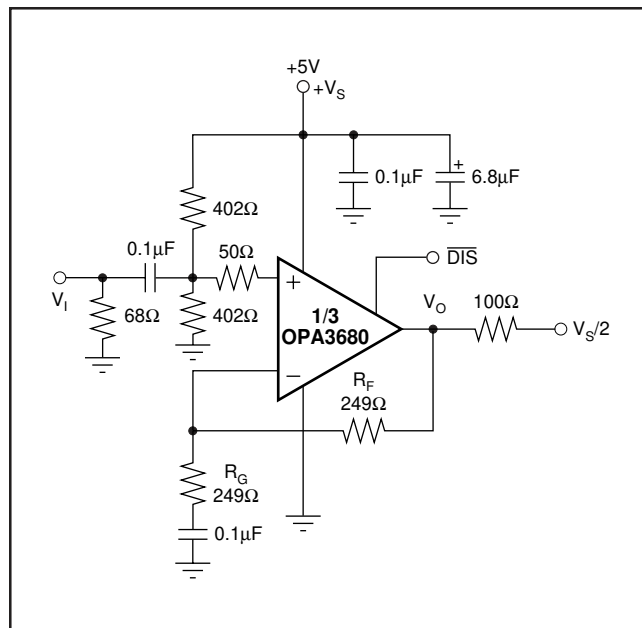

FIGURE 2. AC-Coupled,  $G = +2$ , Single Supply, Specification and Test Circuit.

output voltage can swing to within 1V of either supply pin while delivering >100mA output current. A demanding 100Ω load to a midpoint bias is used in this characterization circuit. The new output stage circuit used in the OPA3680 can deliver large bipolar output currents into this midpoint load with minimal crossover distortion, as shown in the ±5V supply, Harmonic Distortion vs Supply Voltage plot.

### ANALOG DELAY LINE

The diagram on the front page of this data sheet shows an analog delay line using the OPA3680. The first op amp buffers the delay line from the source, and can be used to establish the DC operating point if single +5V supply operation is desired. The last two sections provide an analog delay function given by Equation 1:

$$\text{Delay} = \frac{2\tau}{1+(2\pi f\tau)^2}, \text{ for each section} \quad (1)$$

$$\tau = RC$$

where, f represents the frequency components of interest in the input signal. For input frequencies below  $0.39/2\pi\tau = 2.5\text{MHz}$  the delay will be within 15% of the desired value (2τ). The circuit on the front page gives a delay of 50ns per stage for a total delay of 100ns. Excellent pulse fidelity will be retained as long as the first 5 harmonics are delayed equally. For the circuit shown on the front page, the 5th harmonic should be  $\leq 2.5\text{MHz}/5$ , which will support a square wave up to 500kHz, with good pulse response. The input rise and fall times also need to be  $\geq 0.30/2.5\text{MHz} = 120\text{ns}$  in order to keep the spectral energy within this 2.5MHz limit. Quicker rise or fall times will cause propagation delay errors and excessive pre-shoot.

Shorter delays may be implemented at higher frequencies by adjusting R and C. To maintain bias current cancellation, it is best to simply reduce C without changing R.

The 1pF capacitors limit the noise, while maintaining good pulse response. If desired, these two capacitors may be removed for circuits that produce less delay.

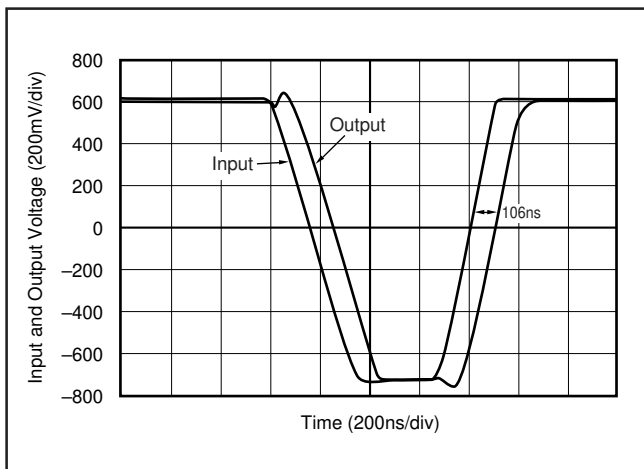

FIGURE 3. Analog Delay Line's Pulse Response.

### INSTRUMENTATION DIFFERENTIAL AMPLIFIER

Figure 4 shows an instrumentation differential amplifier based on the OPA3680. This application benefits from the OPA3680's DC precision, common-mode rejection, high impedance input and low current noise. The resistors on the last (difference) amplifier were selected to keep the loads equal on the input stage op amps. The matched loads and a careful PC board layout can improve 2nd harmonic distortion at higher frequencies.

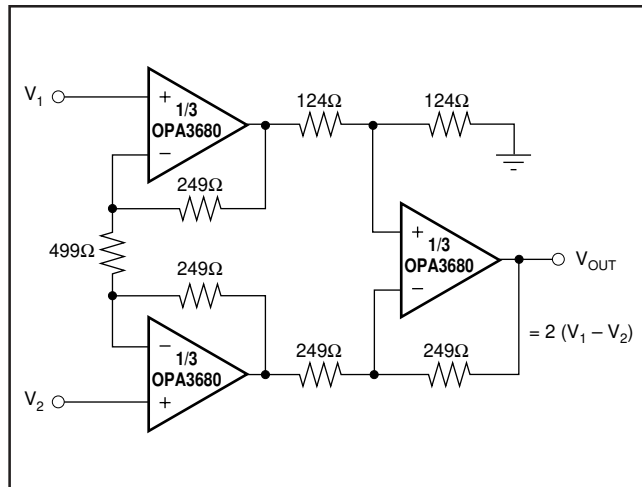

FIGURE 4. Instrumentation Amplifier.

### BUFFERED 2 x 1 MULTIPLEXER

Using two of the three channels in an OPA3680 to select one of two possible input signals, then using the 3rd to isolate the summing point and drive the load, will give a very flexible, wideband, multiplexing capability. Figure 5 shows one example of this where the two input stages have been set up for a gain of +2.

Summing the two output signals together at the output stage buffer's non-inverting input through 400Ω resistors allows excellent isolation between the two channels to be maintained. When one channel is operating, the other will see an attenuated version of the active channel's signal on its inverting input. In this circuit, that signal is attenuated by 20dB at this inactive inverting input—this will keep the swing low enough on the off channel to avoid parasitic turn on at that input stage. The desired signal is attenuated by 0.6V/V due to this resistor divider, then recovered by the gain set in the output stage.

One modification to this circuit would give a high speed switched gain. The same signal would be fed into both inputs and each amplifier would be set to a different gain.

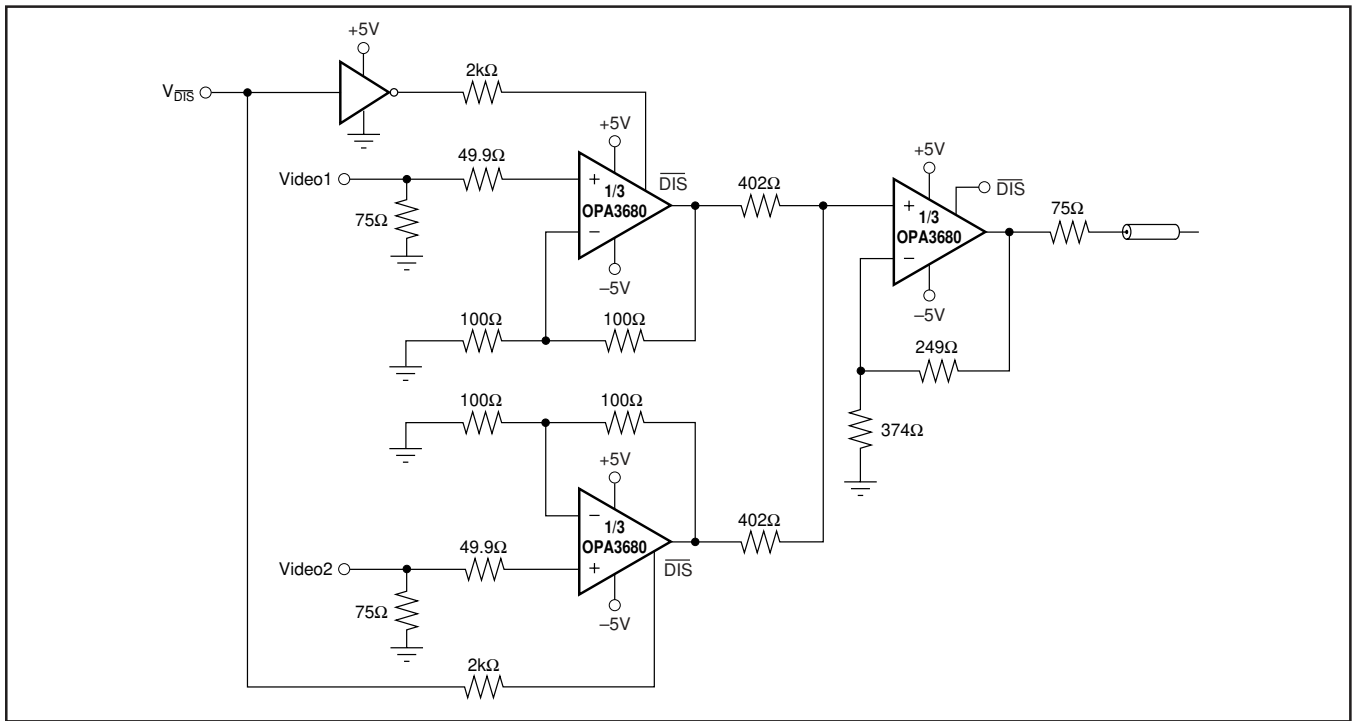

FIGURE 5. Buffered 2-to-1 MUX.

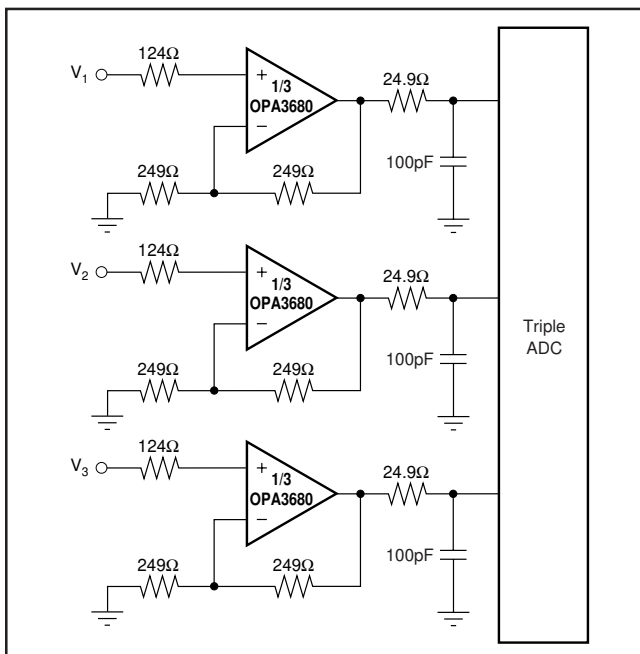

FIGURE 6. Triple ADC Driver.

### TRIPLE ADC DRIVER

Figure 6 shows the OPA3680 driving a triple ADC. Most ADC's are defined for single +5V operation. The OPA3680 can be adapted to single +5V as well using the techniques described for Figure 2. The signal flowthrough pinout for the OPA3680 allows a higher signal fidelity through higher frequencies due to the simplified PC layout requirements.

### WIDEBAND INTEGRATOR

The three unity-gain stable, voltage-feedback amplifiers in the OPA3680 may be used to develop an exceptional integrator function, as shown in Figure 7. This circuit effectively multiplies the open-loop gain using two of the amplifiers and uses the 3rd to provide an input impedance buffering and low output impedance over broad frequencies required for proper operation. The interstage attenuator (resistive divider into the last stage non-inverting input) shown in Figure 6 is critical to maintaining stability. This circuit can deliver a 90° phase shift over a 5-decade frequency span.

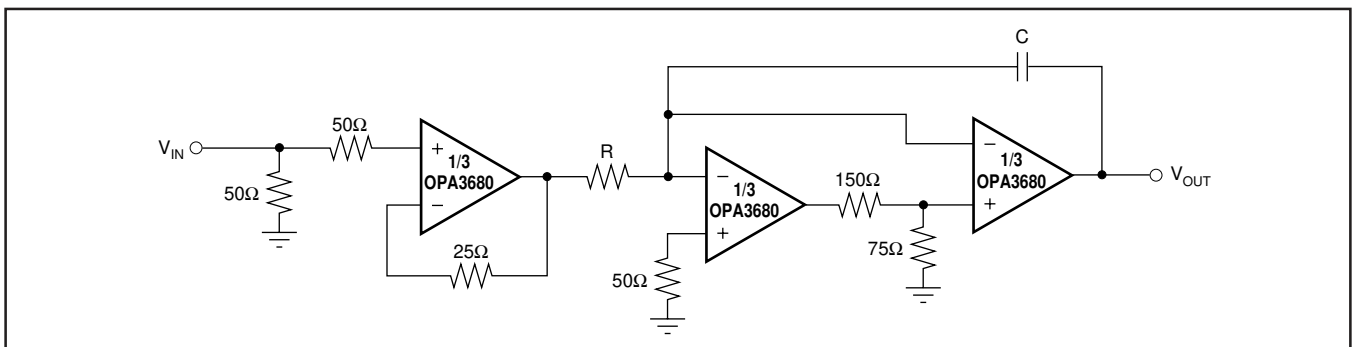

FIGURE 7. Wideband Integrator.

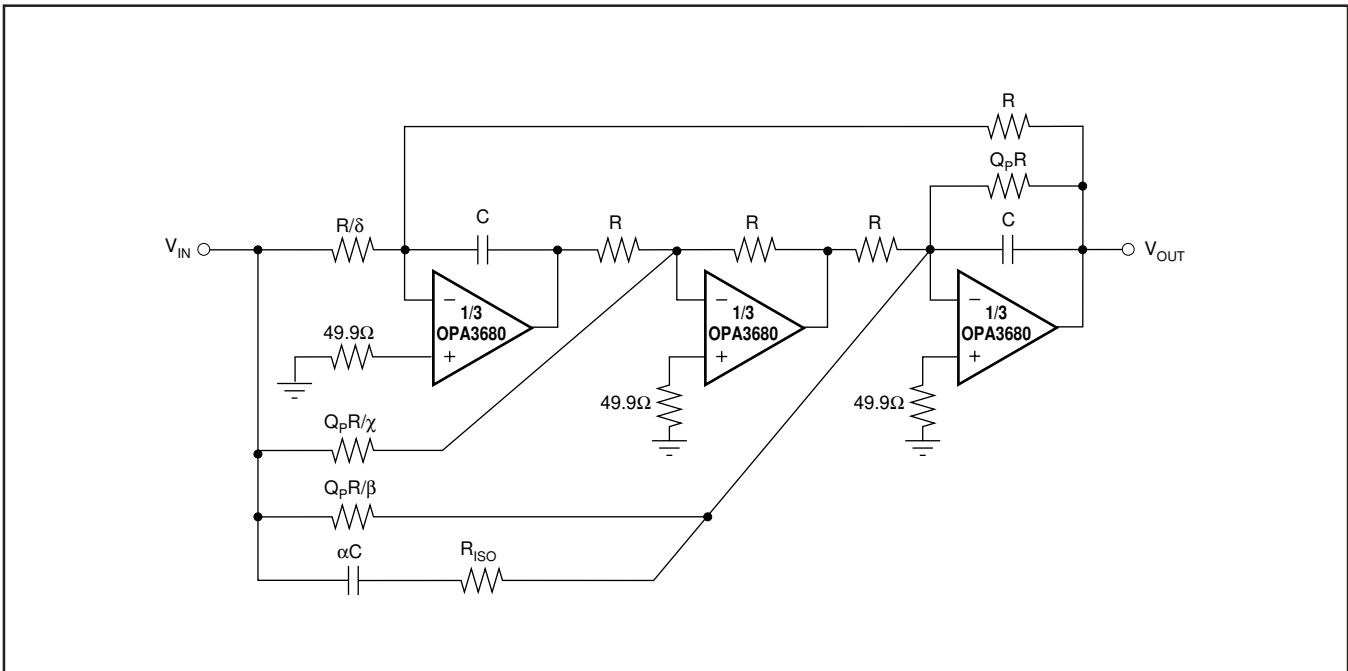

FIGURE 8. State Variable Filter.

## STATE VARIABLE FILTER

Figure 8 shows a state variable filter using the OPA3680. This active filter is quite useful for high Q filter responses, and will produce lowpass, highpass, bandpass, notch and allpass functions. The filter response is:

$$\frac{V_{OUT}}{V_{IN}} = - \frac{s^2(\alpha) + \frac{s\omega_P}{Q_P}(\beta - \chi) + \omega_P^2(\delta)}{s^2 + \frac{s\omega_P}{Q_P} + \omega_P^2} \quad (2)$$

$$\omega_P = \frac{1}{RC}$$

The desired filter frequency response is achieved by the correct selection of the feed-forward components at the input.

The resistor  $R_{ISO}$  isolates the last op amp and the input driver from capacitive loading problems when  $\alpha > 0$ . To ensure good performance, make sure that:

$$\frac{\omega_P}{2\pi} \leq \begin{cases} \frac{f_{GBP}}{20Q_P}, & Q_P > 1 \\ \frac{f_{GBP}}{20}, & Q_P \leq 1 \end{cases} \quad (3)$$

where,  $f_{GBP}$  is the OPA3680's gain bandwidth product (300MHz).

## DESIGN-IN TOOLS

### DEMONSTRATION BOARDS

PC boards are available to assist in the initial evaluation of circuit performance using the OPA3680. They are available free as an unpopulated PC board delivered with descriptive documentation. The summary information for the boards is shown below:

PRODUCT	PACKAGE	BOARD PART NUMBER	LITERATURE REQUEST NUMBER
OPA3680E	16-Lead SSOP	DEM-OPA368xE	MKT-354
OPA3680U	SO-16	DEM-OPA368xU	MKT-364

Contact the Burr-Brown Applications support line (1-800-548-6132) to request this board (ask for the desired literature number).

### MACROMODELS

Computer simulation of circuit performance using SPICE is often useful when analyzing the performance of analog circuits and systems. This is particularly true for Video and RF amplifier circuits where parasitic capacitance and inductance can have a major effect on circuit performance. A SPICE model for the OPA680 is available through either the Burr-Brown Internet web page (<http://www.burr-brown.com>). These models do a good job of predicting small-signal AC and transient performance under a wide variety of operating conditions. They do not do as well in predicting the harmonic distortion, temperature performance or  $dG/d\phi$  characteristics. These models do not attempt to distinguish between the package types in their small-signal AC performance.

# OPERATING SUGGESTIONS

## OPTIMIZING RESISTOR VALUES

Since the OPA3680 is a unity-gain stable, voltage-feedback op amp, a wide range of resistor values may be used for the feedback and gain setting resistors. The primary limits on these values are set by dynamic range (noise and distortion) and parasitic capacitance considerations. For a non-inverting unity gain follower application, the feedback connection should be made with a  $25\Omega$  resistor, not a direct short. This will isolate the inverting input capacitance from the output pin and improve the frequency response flatness. Usually, for  $G > 1$  applications, the feedback resistor value should be between  $100\Omega$  and  $1.5k\Omega$ . Below  $100\Omega$ , the feedback network will present additional output loading which can degrade the harmonic distortion performance of the OPA3680. Above  $1.5k\Omega$ , the typical parasitic capacitance (approximately  $0.2pF$ ) across the feedback resistor may cause unintentional band-limiting in the amplifier response.

A good rule of thumb is to target the parallel combination of  $R_F$  and  $R_G$  (Figure 1) to be less than approximately  $125\Omega$ . The combined impedance  $R_F \parallel R_G$  interacts with the inverting input capacitance, placing an additional pole in the feedback network and thus, a zero in the forward response. Assuming a  $3pF$  total parasitic on the inverting node, holding  $R_F \parallel R_G < 125\Omega$  will keep this pole above  $400MHz$ . By itself, this constraint implies that the feedback resistor  $R_F$  can increase to several  $k\Omega$  at high gains. This is acceptable as long as the pole formed by  $R_F$  and any parasitic capacitance appearing in parallel with it is kept out of the frequency range of interest.

## BANDWIDTH VS GAIN: NON-INVERTING OPERATION

Voltage-feedback op amps exhibit decreasing closed-loop bandwidth as the signal gain is increased. In theory, this relationship is described by the Gain Bandwidth Product (GBP) shown in the specifications. Ideally, dividing GBP by the non-inverting signal gain (also called the Noise Gain, or NG) will predict the closed-loop bandwidth. In practice, this only holds true when the phase margin approaches  $90^\circ$ , as it does in high gain configurations. At low gains (increased feedback factors), most amplifiers will exhibit a more complex response with lower phase margin. The OPA3680 is compensated to give a slightly peaked response in a non-inverting gain of 2 (Figure 1). This results in a typical gain of +2 bandwidth of  $220MHz$ , far exceeding that predicted by dividing the  $300MHz$  GBP by 2. Increasing the gain will cause the phase margin to approach  $90^\circ$  and the bandwidth to more closely approach the predicted value of  $(GBP/NG)$ . At a gain of +10, the  $30MHz$  bandwidth shown in the Typical Specifications agrees with that predicted using the simple formula and the typical GBP of  $300MHz$ .

Frequency response in a gain of +2 may be modified to achieve exceptional flatness simply by increasing the noise gain to 2.5. One way to do this, without affecting the +2 signal gain, is to add a  $453\Omega$  resistor across the two inputs in the circuit of Figure 1. A similar technique may be used to reduce peaking in unity gain (voltage follower) applica-

tions. For example, by using a  $250\Omega$  feedback resistor along with a  $250\Omega$  resistor across the two op amp inputs, the voltage follower response will be similar to the gain of +2 response of Figure 2. Further reducing the value of the resistor across the op amp inputs will further dampen the frequency response due to increased noise gain.

The OPA3680 exhibits minimal bandwidth reduction going to single supply (+5V) operation as compared with  $\pm 5V$ . This is because the internal bias control circuitry retains nearly constant quiescent current as the total supply voltage between the supply pins is changed.

## INVERTING AMPLIFIER OPERATION

Since the OPA3680 is a general purpose, wideband voltage feedback op amp, all of the familiar op amp application circuits are available to the designer. Inverting operation is one of the more common requirements and offers several performance benefits. Figure 9 shows a typical inverting configuration where the I/O impedances and signal gain from Figure 1 are retained in an inverting circuit configuration.

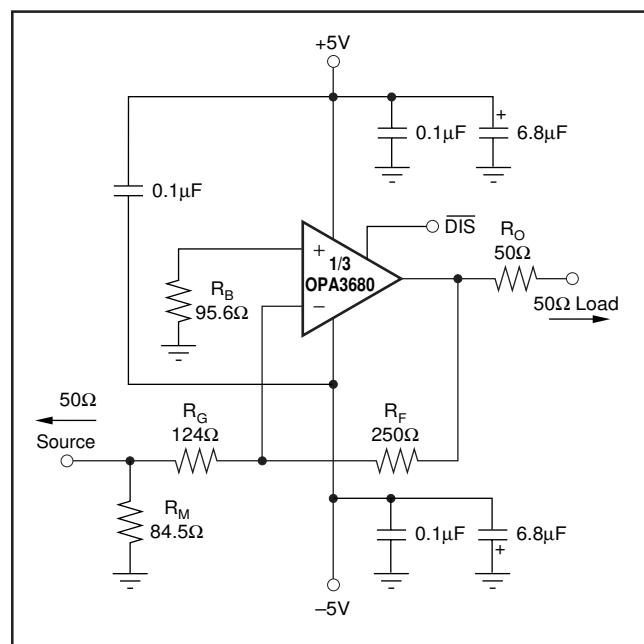

FIGURE 9. Gain of  $-2$  Example Circuit.

In the inverting configuration, three key design considerations must be noted. The first is that the gain resistor ( $R_G$ ) becomes part of the signal channel input impedance. If input impedance matching is desired (which is beneficial whenever the signal is coupled through a cable, twisted pair, long PC board trace or other transmission line conductor),  $R_G$  may be set equal to the required termination value and  $R_F$  adjusted to give the desired gain. This is the simplest approach and results in optimum bandwidth and noise performance. However, at low inverting gains, the resultant feedback resistor value can present a significant load to the amplifier output. For an inverting gain of 2, setting  $R_G$  to  $50\Omega$  for input matching eliminates the need for  $R_M$  but requires a  $100\Omega$  feedback resistor. This has the interesting

advantage that the noise gain becomes equal to 2 for a 50Ω source impedance—the same as the non-inverting circuits considered above. However, the amplifier output will now see the 100Ω feedback resistor in parallel with the external load. In general, the feedback resistor should be limited to the 100Ω to 1.5kΩ range. In this case, it is preferable to increase both the  $R_F$  and  $R_G$  values as shown in Figure 9 and then achieve the input matching impedance with a third resistor ( $R_M$ ) to ground. The total input impedance becomes the parallel combination of  $R_G$  and  $R_M$ .

The second major consideration, touched on in the previous paragraph, is that the signal source impedance becomes part of the noise gain equation and hence influences the bandwidth. For the example in Figure 9, the  $R_M$  value combines in parallel with the external 50Ω source impedance, yielding an effective driving impedance of  $50\Omega \parallel 84.5\Omega = 31.4\Omega$ . This impedance is added in series with  $R_G$  for calculating the noise gain (NG). The resultant NG is 2.6 for Figure 9, as opposed to only 2 if  $R_M$  could be eliminated as discussed above. The bandwidth will therefore be slightly lower for the gain of  $-2$  circuit of Figure 9 than for the gain of  $+2$  circuit of Figure 1.

The third important consideration in inverting amplifier design is setting the bias current cancellation resistor on the non-inverting input ( $R_B$ ). If this resistor is set equal to the total DC resistance looking out of the inverting node, the output DC error, due to the input bias currents, will be reduced to (Input Offset Current) •  $R_F$ . If the 50Ω source impedance is DC-coupled in Figure 9, the total resistance to ground on the inverting input will be 155Ω. Combining this in parallel with the feedback resistor gives the  $R_B = 95.6\Omega$  used in this example. To reduce the additional high frequency noise introduced by this resistor, it is sometimes bypassed with a capacitor. As long as  $R_B < 350\Omega$ , the capacitor is not required since the total noise contribution of all other terms will be less than that of the op amp's input noise voltage. As a minimum, the OPA3680 requires an  $R_B$  value of 50Ω to damp out parasitic-induced peaking—a direct short to ground on the non-inverting input runs the risk of a very high frequency instability in the input stage.

## OUTPUT CURRENT AND VOLTAGE

The OPA3680 provides output voltage and current capabilities that are unsurpassed in a low cost monolithic op amp. Under no-load conditions at +25°C, the output voltage typically swings closer than 1V to either supply rail; the guaranteed swing limit is within 1.2V of either rail. Into a 15Ω load (the minimum tested load), it is guaranteed to deliver more than ±135mA.

The specifications described above, though familiar in the industry, consider voltage and current limits separately. In many applications, it is the voltage • current, or V-I product, which is more relevant to circuit operation. Refer to the “Output Voltage and Current Limitations” plot in the Typical Performance Curves. The X and Y axes of this graph show the zero-voltage output current limit and the zero-current output voltage limit, respectively. The four quadrants give a more detailed view of the OPA3680's output

drive capabilities, noting that the graph is bounded by a “Safe Operating Area” of 1W maximum internal power dissipation for a single channel. Superimposing resistor load lines onto the plot shows that the OPA3680 can drive ±2.5V into 25Ω or ±3.5V into 50Ω without exceeding the output capabilities or the 1W dissipation limit. A 100Ω load line (the standard test circuit load) shows the full ±3.9V output swing capability, as shown in the typical specifications.

The minimum specified output voltage and current specifications over temperature are set by worst-case simulations at the cold temperature extreme. Only at cold startup will the output current and voltage decrease to the numbers shown in the guaranteed tables. As the output transistors deliver power, their junction temperatures will increase, decreasing their  $V_{BE}$ 's (increasing the available output voltage swing) and increasing their current gains (increasing the available output current). In steady-state operation, the available output voltage and current will always be greater than that shown in the over-temperature specifications since the output stage junction temperatures will be higher than the minimum specified operating ambient.

To maintain maximum output stage linearity, no output short-circuit protection is provided. This will not normally be a problem since most applications include a series matching resistor at the output that will limit the internal power dissipation if the output side of this resistor is shorted to ground. **However, shorting the output pin directly to the adjacent positive power supply pins will, in most cases, destroy the amplifier.** If additional short-circuit protection is required, consider a small series resistor in the power supply leads. Under heavy output loads, this will reduce the available output voltage swing. A 5Ω series resistor in each power supply lead will limit the internal power dissipation to less than 1W for an output short circuit while decreasing the available output voltage swing only 0.5V for up to 100mA desired load currents. Always place the 0.1μF power supply decoupling capacitors after these supply current limiting resistors directly on the supply pins.

## DRIVING CAPACITIVE LOADS

One of the most demanding and yet very common load conditions for an op amp is capacitive loading. Often, the capacitive load is the input of an A/D converter—including additional external capacitance which may be recommended to improve A/D linearity. A high speed, high open-loop gain amplifier like the OPA3680 can be very susceptible to decreased stability and closed-loop response peaking when a capacitive load is placed directly on the output pin. When the amplifier's open-loop output resistance is considered, this capacitive load introduces an additional pole in the signal path that can decrease the phase margin. Several external solutions to this problem have been suggested. When the primary considerations are frequency response flatness, pulse response fidelity and/or distortion, the simplest and most effective solution is to isolate the capacitive load from the feedback loop by inserting a series isolation resistor between the amplifier output and the capacitive load. This does not eliminate the pole from the loop



response, but rather shifts it and adds a zero at a higher frequency. The additional zero acts to cancel the phase lag from the capacitive load pole, thus increasing the phase margin and improving stability.

The Typical Performance Curves show the recommended  $R_S$  versus capacitive load and the resulting frequency response at the load. Parasitic capacitive loads greater than 2pF can begin to degrade the performance of the OPA3680. Long PC board traces, unmatched cables, and connections to multiple devices can easily exceed this value. Always consider this effect carefully, and add the recommended series resistor as close as possible to the OPA3680 output pin (see Board Layout Guidelines).

The criterion for setting this  $R_S$  resistor is a maximum bandwidth, flat frequency response at the load. For the OPA3680 operating in a gain of +2, the frequency response at the output pin is already slightly peaked without the capacitive load requiring relatively high values of  $R_S$  to flatten the response at the load. Increasing the noise gain will reduce the peaking as described previously. The circuit of Figure 10 demonstrates this technique, allowing lower values of  $R_S$  to be used for a given capacitive load. This was used to generate the Recommended  $R_S$  versus Capacitive Load plots.

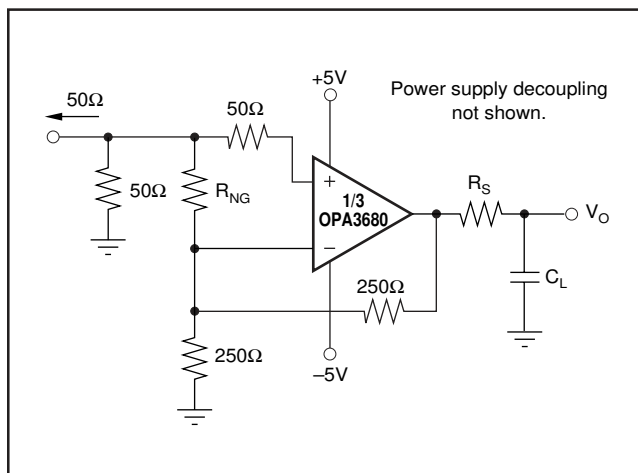

FIGURE 10. Capacitive Load Driving with Noise Gain Tuning.

This gain of +2 circuit includes a noise gain tuning resistor across the two inputs to increase the noise gain, increasing the unloaded phase margin for the op amp. Although this technique will reduce the required  $R_S$  resistor for a given capacitive load, it does increase the noise at the output. It also will decrease the loop gain, slightly decreasing the distortion performance. If, however, the dominant distortion mechanism arises from a high  $R_S$  value, significant dynamic range improvement can be achieved using this technique.

### DISTORTION PERFORMANCE

The OPA3680 provides good distortion performance into a 100Ω load on ±5V supplies. Relative to alternative solutions, it provides exceptional performance into lighter loads and/or operating on a single +5V supply.

The distortion plots show which changes in operation will improve distortion. Increasing the load impedance improves distortion directly. Remember that the total load includes the feedback network; in the non-inverting configuration (Figure 1) this is sum of  $R_F + R_G$ , while in the inverting configuration (Figure 9), it is just  $R_F$ . Also, providing an additional supply decoupling capacitor (0.1μF) between the supply pins (for bipolar operation) improves the 2nd-order distortion slightly (3dB to 6dB).

In most op amps, increasing the output voltage swing increases intermodulation distortion directly. The new output stage used in the OPA3680 actually holds the difference between fundamental power and the 3rd-order intermodulation powers relatively constant with increasing output power until very large output swings are required (> 4Vp-p). The 3rd-order spurious levels are extremely low at low output power levels. The output stage continues to hold them low even as the fundamental power reaches very high levels. As the Typical Performance Curves show, the spurious intermodulation powers do not increase as predicted by a traditional intercept model. As the fundamental power level increases, the dynamic range does not decrease significantly. For 2 tones centered at 20MHz, with 10dBm/ tone into a matched 50Ω load (i.e., 2Vp-p for each tone at the load, which requires 8Vp-p for the overall two-tone envelope at the output pin), the Typical Performance Curves show 57dBc difference between the test tone powers and the 3rd-order intermodulation spurious powers. This exceptional performance improves further when operating at lower frequencies.

### NOISE PERFORMANCE

High slew rate, unity gain stable, voltage feedback op amps usually achieve their slew rate at the expense of a higher input noise voltage. The 4.8nV/√Hz input voltage noise for the OPA3680 is, however, much lower than comparable amplifiers. The input-referred voltage noise, and the two input-referred current noise terms, combine to give low output noise under a wide variety of operating conditions. Figure 11 shows the op amp noise analysis model with all the noise terms included. In this model, all noise terms are taken to be noise voltage or current density terms in either nV/√Hz or pA/√Hz.

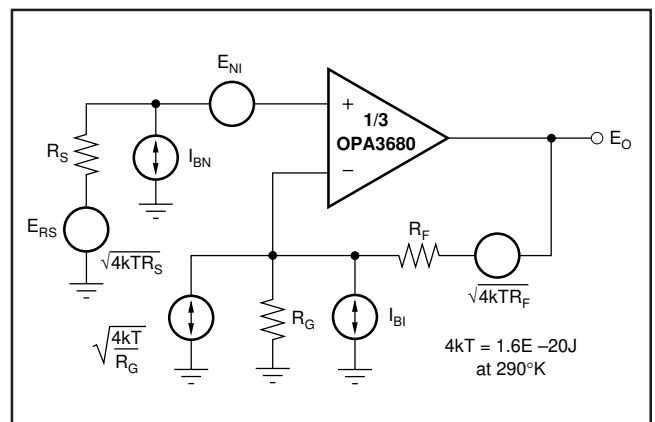

FIGURE 11. Op Amp Noise Analysis Model.

The total output spot noise voltage can be computed as the square root of the sum of all squared output noise voltage contributors. Equation 4 shows the general form for the output noise voltage using the terms shown in Figure 11.

$$E_O = \sqrt{(E_{NI}^2 + (I_{BN}R_S)^2 + 4kTR_S)NG^2 + (I_{BI}R_F)^2 + 4kTR_F}NG \quad (4)$$

Dividing this expression by the noise gain ( $NG = (1+R_F/R_G)$ ) will give the equivalent input-referred spot noise voltage at the non-inverting input, as shown in Equation 5:

$$E_N = \sqrt{E_{NI}^2 + (I_{BN}R_S)^2 + 4kTR_S + \left(\frac{I_{BI}R_F}{NG}\right)^2 + \frac{4kTR_F}{NG}} \quad (5)$$

Evaluating these two equations for the OPA3680 circuit and component values shown in Figure 1 will give a total output spot noise voltage of  $11\text{nV}/\sqrt{\text{Hz}}$  and a total equivalent input spot noise voltage of  $5.5\text{nV}/\sqrt{\text{Hz}}$ . This is including the noise added by the bias current cancellation resistor ( $100\Omega$ ) on the non-inverting input. This total input-referred spot noise voltage is only slightly higher than the  $4.8\text{nV}/\sqrt{\text{Hz}}$  specification for the op amp voltage noise alone. This will be the case as long as the impedances appearing at each op amp input are limited to the previously recommend maximum value of  $125\Omega$ . Keeping both ( $R_F \parallel R_G$ ) and the non-inverting input source impedance less than  $125\Omega$  will satisfy both noise and frequency response flatness considerations. Since the resistor-induced noise is relatively negligible, additional capacitive decoupling across the bias current cancellation resistor ( $R_B$ ) for the inverting op amp configuration of Figure 9 is not required.

## DC ACCURACY AND OFFSET CONTROL

The balanced input stage of a wideband voltage feedback op amp allows good output DC accuracy in a wide variety of applications. The power supply current trim for the OPA3680 gives even tighter control than comparable products. Although the high speed input stage does require relatively high input bias current (typically  $14\mu\text{A}$  out of each input terminal), the close matching between them may be used to reduce the output DC error caused by this current. The total output offset voltage may be considerably reduced by matching the DC source resistances appearing at the two inputs. This reduces the output DC error due to the input bias currents to the offset current times the feedback resistor. Evaluating the configuration of Figure 1, using worst-case  $+25^\circ\text{C}$  input offset voltage and current specifications, gives

a worst-case output offset voltage equal to: – (NG = non-inverting signal gain)

$$\begin{aligned} & \pm(NG \cdot V_{OS(\text{MAX})}) \pm (R_F \cdot I_{OS(\text{MAX})}) \quad (6) \\ & = \pm(2 \cdot 4.5\text{mV}) \pm (250\Omega \cdot 0.7\mu\text{A}) \\ & = \pm 9.2\text{mV} \end{aligned}$$

A fine scale output offset null, or DC operating point adjustment, is often required. Numerous techniques are available for introducing DC offset control into an op amp circuit. Most of these techniques eventually reduce to adding a DC current through the feedback resistor. In selecting an offset trim method, one key consideration is the impact on the desired signal path frequency response. If the signal path is intended to be non-inverting, the offset control is best applied as an inverting summing signal to avoid interaction with the signal source. If the signal path is intended to be inverting, applying the offset control to the non-inverting input may be considered. However, the DC offset voltage on the summing junction will set up a DC current back into the source which must be considered. Applying an offset adjustment to the inverting op amp input can change the noise gain and frequency response flatness. For a DC-coupled inverting amplifier, Figure 12 shows one example of an offset adjustment technique that has minimal impact on the signal frequency response. In this case, the DC offsetting current is brought into the inverting input node through resistor values that are much larger than the signal path resistors. This will insure that the adjustment circuit has minimal effect on the loop gain and hence the frequency response.

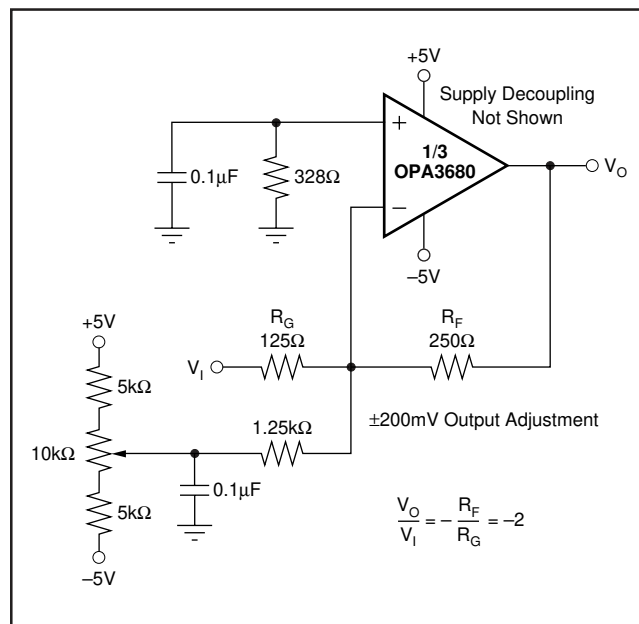

FIGURE 12. DC-Coupled, Inverting Gain of  $-2$  with Offset Adjustment.

## DISABLE OPERATION

The OPA3680 provides an optional disable feature on each channel that may be used either to reduce system power or to implement a simple channel multiplexing operation. If the  $\overline{\text{DIS}}$  control pin of each channel is left unconnected, the OPA3680 will operate normally. To disable, the control pin must be asserted LOW. Figure 13 shows a simplified internal circuit for the disable control feature available on each channel.

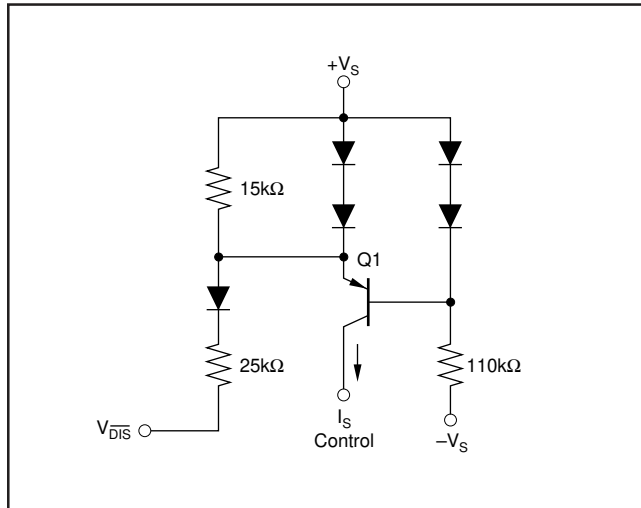

FIGURE 13. Simplified Disable Control Circuit.

In normal operation, base current to Q1 is provided through the 110kΩ resistor, while the emitter current through the 15kΩ resistor sets up a voltage drop that is inadequate to turn on the two diodes in Q1's emitter. As  $\overline{\text{V}}_{\text{DIS}}$  is pulled LOW, additional current is pulled through the 15kΩ resistor eventually turning on those two diodes ( $\approx 100\mu\text{A}$ ). At this point, any further current pulled out of  $\overline{\text{V}}_{\text{DIS}}$  goes through those diodes holding the emitter-base voltage of Q1 at approximately zero volts. This shuts off the collector current out of Q1, turning the amplifier off. The supply current in the disable mode are only those required to operate the circuit of Figure 13. Additional circuitry ensures that turn-on time occurs faster than turn-off time (make-before-break).

When disabled, the output and input nodes go to a high impedance state. If the OPA3680 is operating in a gain of +1, this will show a very high impedance at the output and exceptional signal isolation. If operating at a gain greater than +1, the total feedback network resistance ( $R_F + R_G$ ) will appear as the impedance looking back into the output, but the circuit will still show very high forward and reverse isolation. If configured as an inverting amplifier, the input and output will be connected through the feedback network resistance ( $R_F + R_G$ ) and the isolation will be very poor as a result.

One key parameter in disable operation is the output glitch when switching in and out of the disabled mode. Figure 14 shows these glitches for the circuit of Figure 1 with the input signal at 0V. The glitch waveform at the output pin is plotted along with the  $\overline{\text{DIS}}$  pin voltage.

The transition edge rate ( $dv/dt$ ) of the  $\overline{\text{DIS}}$  control line will influence this glitch. For the plot of Figure 14, the edge rate was reduced until no further reduction in glitch amplitude was observed. This approximately 1V/ns maximum slew rate may be achieved by adding a simple RC filter into the DIS pin from a higher speed logic line. If extremely fast transition logic is used, a 1kΩ series resistor between the logic gate and the DIS input pin will provide adequate bandlimiting using just the parasitic input capacitance on the DIS pin while still ensuring adequate logic level swing.

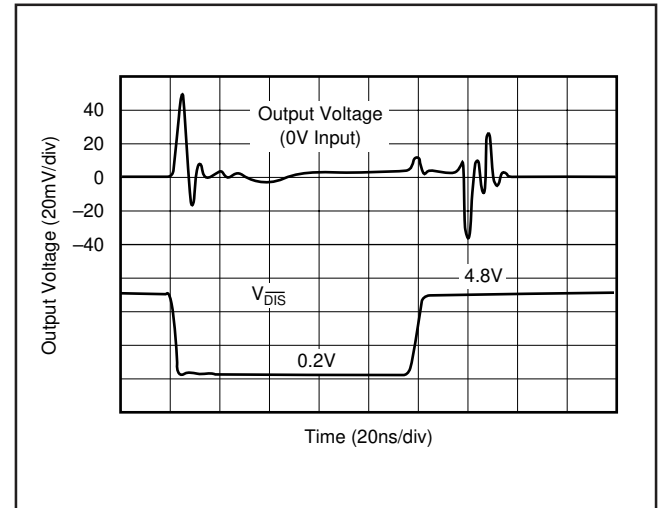

FIGURE 14. Disable/Enable Glitch.

## THERMAL ANALYSIS

Due to the high output power capability of the OPA3680, heatsinking or forced airflow may be required under extreme operating conditions. Maximum desired junction temperature will set the maximum allowed internal power dissipation as described below. In no case should the maximum junction temperature be allowed to exceed 175°C.

Operating junction temperature ( $T_J$ ) is given by  $T_A + P_D \cdot \theta_{JA}$ . The total internal power dissipation ( $P_D$ ) is the sum of quiescent power ( $P_{DQ}$ ) and additional power dissipated in the output stage ( $P_{DL}$ ) to deliver load power. Quiescent power is simply the specified no-load supply current times the total supply voltage across the part.  $P_{DL}$  will depend on the required output signal and load but would, for a grounded resistive load, be at a maximum when the output is fixed at a voltage equal to 1/2 of either supply voltage (for equal bipolar supplies). Under this condition,  $P_{DL} = V_S^2 / (4 \cdot R_L)$  where  $R_L$  includes feedback network loading.

Note that it is the power in the output stage and not into the load that determines internal power dissipation.

As a worst-case example, compute the maximum  $T_J$  using an OPA3680E in the circuit of Figure 1 operating at the maximum specified ambient temperature of +85°C and driving a grounded 100Ω load.

$$P_D = 10\text{V} \cdot 21\text{mA} + 3 \cdot [5^2 / (4 \cdot (100\Omega \parallel 500\Omega))] = 435\text{mW}$$

$$\text{Maximum } T_J = +85^\circ\text{C} + (0.44\text{W} \cdot 100^\circ\text{C/W}) = 129^\circ\text{C}$$

This worst-case condition is still well within rated maximum  $T_j$  for this 100 $\Omega$  load. Heavier loads may, however, exceed the 175°C maximum junction temperature rating. Careful attention to internal power dissipation is required and perhaps airflow considered under extreme conditions.

## BOARD LAYOUT GUIDELINES

Achieving optimum performance with a high frequency amplifier like the OPA3680 requires careful attention to board layout parasitics and external component types. Recommendations that will optimize performance include:

a) **Minimize parasitic capacitance** to any AC ground for all of the signal I/O pins. Parasitic capacitance on the output and inverting input pins can cause instability: on the non-inverting input, it can react with the source impedance to cause unintentional bandlimiting. To reduce unwanted capacitance, a window around the signal I/O pins should be opened in all of the ground and power planes around those pins. Otherwise, ground and power planes should be unbroken elsewhere on the board.

b) **Minimize the distance** (< 0.25") from the power supply pins to high frequency 0.1 $\mu$ F decoupling capacitors. At the device pins, the ground and power plane layout should not be in close proximity to the signal I/O pins. Avoid narrow power and ground traces to minimize inductance between the pins and the decoupling capacitors. The power supply connections should always be decoupled with these capacitors. An optional supply decoupling capacitor (0.1 $\mu$ F) across the two power supplies (for bipolar operation) will improve 2nd harmonic distortion performance. Larger (2.2 $\mu$ F to 6.8 $\mu$ F) decoupling capacitors, effective at lower frequency, should also be used on the main supply pins. These may be placed somewhat farther from the device and may be shared among several devices in the same area of the PC board.

c) **Careful selection and placement of external components will preserve the high frequency performance of the OPA3680.** Resistors should be a very low reactance type. Surface-mount resistors work best and allow a tighter overall layout. Metal film or carbon composition axially-leaded resistors can also provide good high frequency performance. Again, keep their leads and PC board traces as short as possible. Never use wirewound type resistors in a high frequency application. Since the output pin and inverting input pin are the most sensitive to parasitic capacitance, always position the feedback and series output resistor, if any, as close as possible to the output pin. Other network components, such as non-inverting input termination resistors, should also be placed close to the package. Where double-side component mounting is allowed, place the feedback resistor directly under the package on the other side of the board between the output and inverting input pins. Even with a low parasitic capacitance shunting the external resis-

tors, excessively high resistor values can create significant time constants that can degrade performance. Good axial metal film or surface-mount resistors have approximately 0.2pF in shunt with the resistor. For resistor values > 1.5k $\Omega$ , this parasitic capacitance can add a pole and/or zero below 500MHz that can effect circuit operation. Keep resistor values as low as possible consistent with load driving considerations. The 250 $\Omega$  feedback used in the typical performance specifications is a good starting point for design. Note that a 25 $\Omega$  feedback resistor, rather than a direct short, is suggested for the unity gain follower application. This effectively isolates the inverting input capacitance from the output pin that would otherwise cause an additional peaking in the gain of +1 frequency response.

d) **Connections to other wideband devices** on the board may be made with short direct traces or through on-board transmission lines. For short connections, consider the trace and the input to the next device as a lumped capacitive load. Relatively wide traces (50 to 100mils) should be used, preferably with ground and power planes opened up around them. Estimate the total capacitive load and set  $R_S$  from the plot of Recommended  $R_S$  vs Capacitive Load. Low parasitic capacitive loads (< 5pF) may not need an  $R_S$  since the OPA3680 is nominally compensated to operate with a 2pF parasitic load. Higher parasitic capacitive loads without an  $R_S$  are allowed as the signal gain increases (increasing the unloaded phase margin) If a long trace is required, and the 6dB signal loss intrinsic to a doubly terminated transmission line is acceptable, implement a matched impedance transmission line using microstrip or stripline techniques (consult an ECL design handbook for microstrip and stripline layout techniques). A 50 $\Omega$  environment is normally not necessary on board, and in fact, a higher impedance environment will improve distortion as shown in the distortion versus load plots. With a characteristic board trace impedance defined (based on board material and trace dimensions), a matching series resistor into the trace from the output of the OPA3680 is used as well as a terminating shunt resistor at the input of the destination device. Remember also that the terminating impedance will be the parallel combination of the shunt resistor and the input impedance of the destination device; this total effective impedance should be set to match the trace impedance. The high output voltage and current capability of the OPA3680 allows multiple destination devices to be handled as separate transmission lines, each with their own series and shunt terminations. If the 6dB attenuation of a doubly terminated transmission line is unacceptable, a long trace can be series-terminated at the source end only. Treat the trace as a capacitive load in this case and set the series resistor value as shown in the plot of Recommended  $R_S$  vs Capacitive Load. This will not preserve signal integrity as well as a doubly terminated line. If the input impedance of the destination device is low, there will be some signal attenuation due to the voltage divider formed by the series output into the terminating impedance.

## INPUT AND ESD PROTECTION

The OPA3680 is built using a very high speed complementary bipolar process. The internal junction breakdown voltages are relatively low for these very small geometry devices. These breakdowns are reflected in the Absolute Maximum Ratings table. All device pins are protected with internal ESD protection diodes to the power supplies as shown in Figure 15.

These diodes provide moderate protection to input overdrive voltages above the supplies as well. The protection diodes can typically support 30mA continuous current. Where higher currents are possible (e.g., in systems with  $\pm 15\text{V}$  supply parts driving into the OPA3680), current-limiting series resistors should be added into the two inputs. Keep these resistor values as low as possible since high values degrade both noise performance and frequency response.

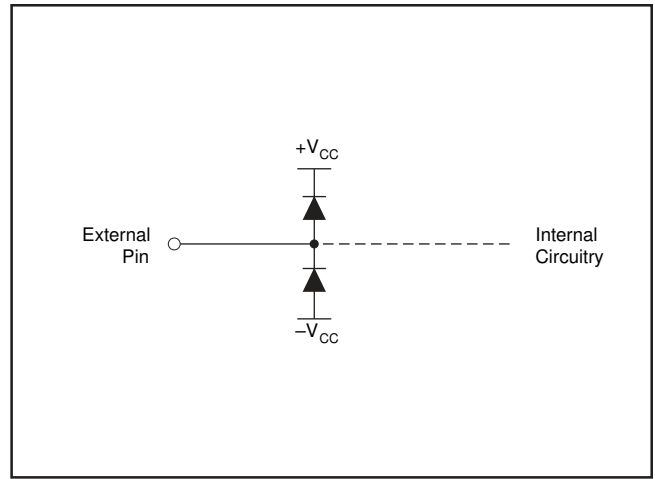

FIGURE 15. Internal ESD Protection.

## **IMPORTANT NOTICE**

Texas Instruments and its subsidiaries (TI) reserve the right to make changes to their products or to discontinue any product or service without notice, and advise customers to obtain the latest version of relevant information to verify, before placing orders, that information being relied on is current and complete. All products are sold subject to the terms and conditions of sale supplied at the time of order acknowledgment, including those pertaining to warranty, patent infringement, and limitation of liability.

TI warrants performance of its semiconductor products to the specifications applicable at the time of sale in accordance with TI's standard warranty. Testing and other quality control techniques are utilized to the extent TI deems necessary to support this warranty. Specific testing of all parameters of each device is not necessarily performed, except those mandated by government requirements.

Customers are responsible for their applications using TI components.

In order to minimize risks associated with the customer's applications, adequate design and operating safeguards must be provided by the customer to minimize inherent or procedural hazards.

TI assumes no liability for applications assistance or customer product design. TI does not warrant or represent that any license, either express or implied, is granted under any patent right, copyright, mask work right, or other intellectual property right of TI covering or relating to any combination, machine, or process in which such semiconductor products or services might be or are used. TI's publication of information regarding any third party's products or services does not constitute TI's approval, warranty or endorsement thereof.