

Description

The AZ39151 is a 1.5A, high accuracy linear voltage regulator. It features 375mV dropout voltage at 1.5A output current and low ground current over all operating conditions.

The AZ39151 is specifically designed for low voltage, high current output systems, such as PC add-in cards where their tiny dropout voltage and ground current values are important attributes.

The AZ39151 has fixed 3.3V, 5.0V versions and ADJ (1.25V) version.

The AZ39151 is available in TO-252-5 package.

Features

- Minimum Guaranteed Output Current: 1.5A
- Low Dropout Voltage: 375mV at $I_{OUT} = 1.5A$
- Output Accuracy: $\pm 1\%$
- Low Ground Current
- Internal Current and Thermal Limit
- Reversed-battery and Reversed-lead Insertion Protection
- Fast Transient Response
- TTL/CMOS Compatible Enable Pin

Pin Assignments

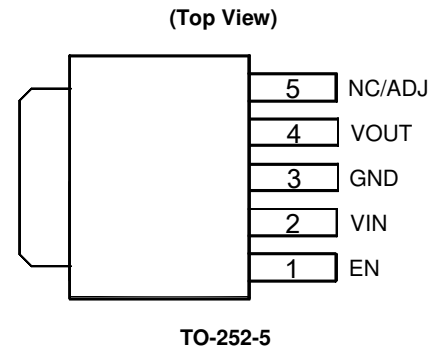

Applications

- Set-top Box
- Hi-end DVD Player/Recorder
- LCD TV/PDP
- LDO Linear Regulator for PC Add-in Cards
- High Efficiency Linear Power Supplies
- SMPS Post Regulator

Typical Applications Circuit

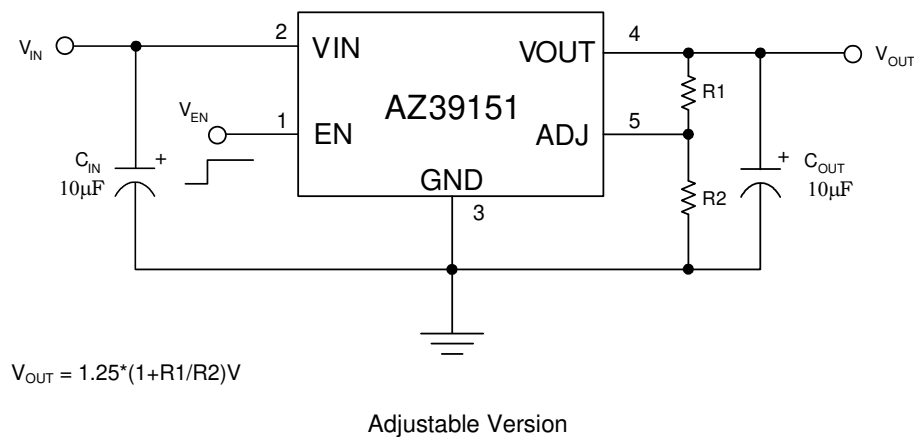
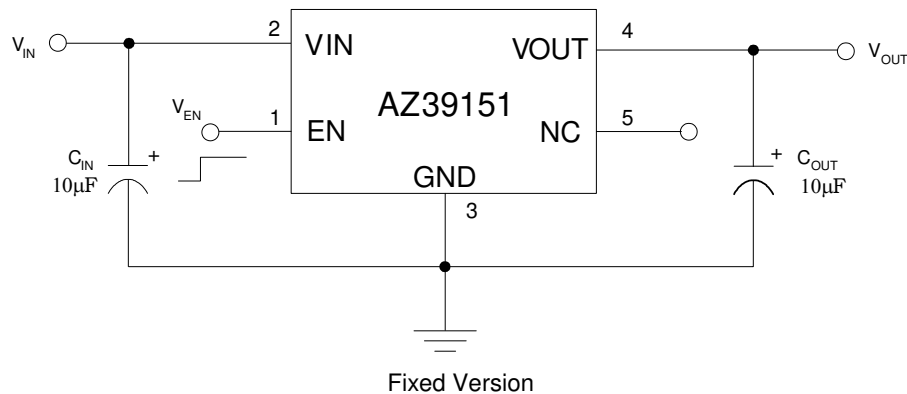

Pin Description

Pin Number	Pin Name	Function
1	EN	Enable: TTL/CMOS compatible input. Logic high=enable; Logic low or open=shutdown
2	VIN	Unregulated input
3	GND	Ground pin. This pin and TAB are internally connected
4	VOUT	Regulated output
5	NC/ADJ	No Connection / Adjustable Output

Functional Block Diagram

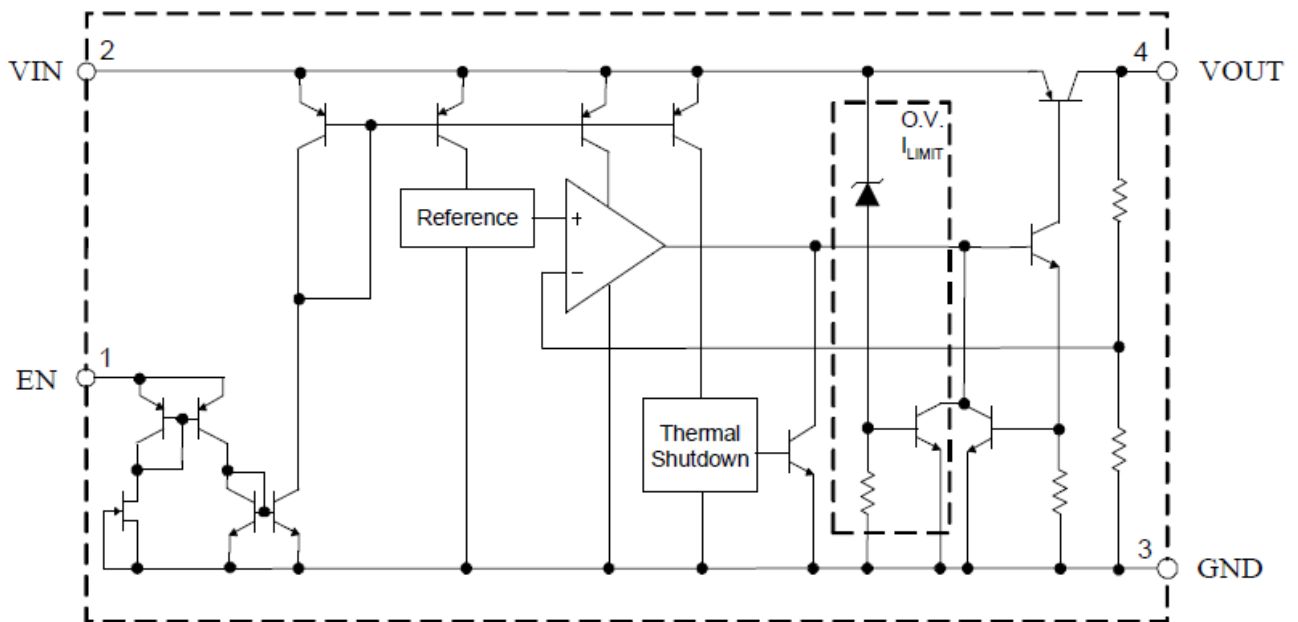

Fixed Version

Functional Block Diagram (Cont.)

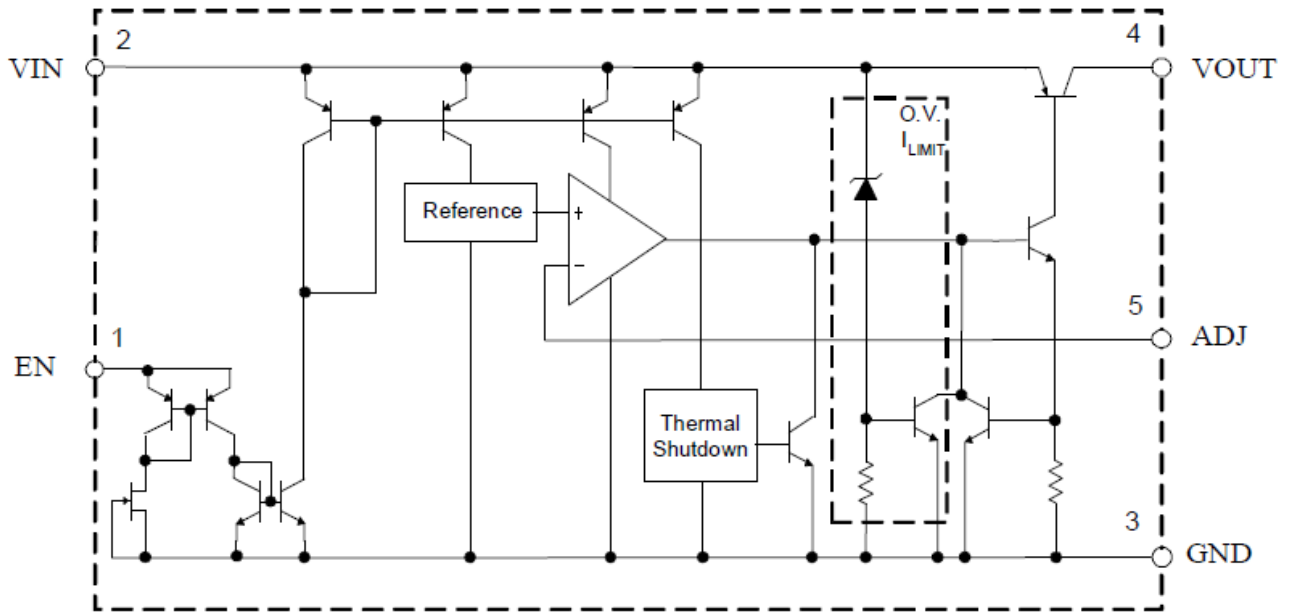

Adjustable Version

Absolute Maximum Ratings (Note 1)

Symbol	Parameter	Rating	Unit
V_{IN}	Input Voltage	15	V
V_{EN}	Enable Voltage	15	V
T_J	Operating Junction Temperature	+150	°C
T_{STG}	Storage Temperature Range	-65 to +150	°C
T_{LEAD}	Lead Temperature (Soldering, 10sec)	+260	°C
ESD	ESD (Human Body Model)	5000	V
ESD	ESD (Machine Model)	450	V
θ_{JA}	Thermal Resistance	100	°C/W

Note: 1. Stresses greater than those listed under "Absolute Maximum Ratings" may cause permanent damage to the device. These are stress ratings only, and functional operation of the device at these or any other conditions beyond those indicated under "Recommended Operating Conditions" is not implied. Exposure to "Absolute Maximum Ratings" for extended periods may affect device reliability.

Recommended Operating Conditions

Symbol	Parameter	Min	Max	Unit
V_{IN}	Input Voltage	—	13.5	V
V_{EN}	Enable Voltage	—	13.5	V
T_J	Operating Junction Temperature	-40	+125	°C

Electrical Characteristics (Operating Conditions: $V_{IN} = V_{OUT} + 1V$, $I_{OUT} = 10mA$, $C_{IN} = 10\mu F$, $C_{OUT} = 10\mu F$, $T_J = +25^\circ C$, unless otherwise specified. The **Boldface** applies over $-40^\circ C \leq T_J \leq +125^\circ C$.)

Symbol	Parameter	Conditions	Min	Typ	Max	Unit	
V_{OUT}	Output Voltage	—	-1	—	1	%	
		$10mA \leq I_{OUT} \leq 1.5A$, $V_{OUT} + 1V \leq V_{IN} \leq 13.5V$	-2	—	2		
V_{RLINE}	Line Regulation	$V_{OUT} + 1V \leq V_{IN} \leq 13.5V$	—	3	25	mV	
V_{RLOAD}	Load Regulation	$10mA \leq I_{OUT} \leq 1.5A$	—	10	50	mV	
$\Delta V_{OUT}/\Delta T$	Output Voltage Temperature Coefficient (Note 2)	—	—	100	500	$\mu V/^\circ C$	
$(\Delta V_{OUT}/V_{OUT})\Delta T$		—	—	20	100	ppm/ $^\circ C$	
V_{DROP}	Dropout Voltage (Note 3)	$\Delta V_{OUT} = 1\%$	$I_{OUT} = 100mA$	—	80	200	mV
			$I_{OUT} = 750mA$	—	260	—	mV
			$I_{OUT} = 1.5A$	—	375	700	mV
I_{GND}	Ground Current	$I_{OUT} = 750mA$	—	5	10	mA	
		$I_{OUT} = 1.5A$	—	17	34	mA	
I_{STD}	Standby Current	$V_{IN} = 13.5V$, $V_{EN} = 0V$	—	130	220	μA	
$I_{GND(DO)}$	Dropout Ground Pin Current	$V_{IN} \leq V_{OUT(NOMINAL)} - 0.5V$	—	5	—	mA	
I_{SHORT}	Short Circuit Current	$V_{OUT} = 0V$	—	2.8	—	A	
—	Output Noise Voltage (rms)	10Hz to 100kHz, $I_{OUT} = 100mA$	—	200	—	μV	
$I_{LOAD(MIN)}$	Minimum Load Current	—	—	—	5	mA	
PSRR	Power Supply Ripple Rejection	$f = 120Hz$, $I_{OUT} = 750mA$	49	65	—	dB	
Enable Input							
V_{EN}	Enable Voltage	Logic low (off)	—	—	0.8	V	
		Logic high (on)	2.25	—	—		
I_{EN}	Enable Current	$V_{EN} = V_{IN}$	—	15	35	μA	
		$V_{EN} = 0.8V$	—	—	4		
$I_{OUT(SHDN)}$	Shutdown Output Current	$V_{EN} \leq 0.8V$, $V_{IN} \leq 8V$, $V_{OUT} = 0V$	—	5	10	μA	

- Notes:
- Output voltage temperature coefficient is defined as the worst case voltage change divided by the total temperature range.
 - Dropout voltage is defined as the input-to-output differential when the output voltage drops to 99% of its nominal value which is measured at $V_{OUT} + 1V$ applied to V_{IN} .

Performance Characteristics

Dropout Voltage vs. Output Current

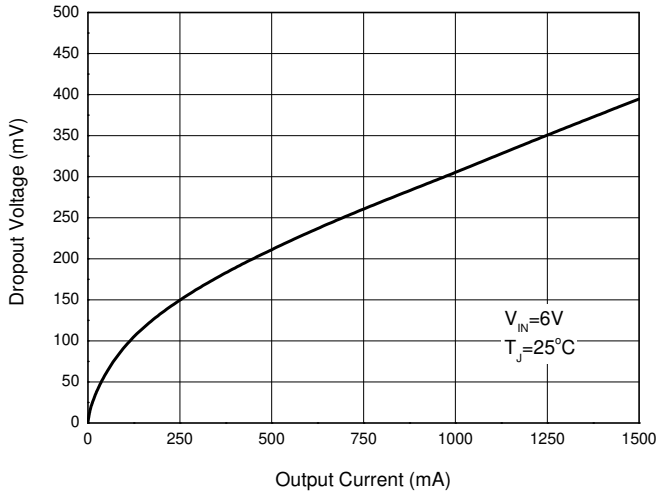

Dropout Voltage vs. Junction Temperature

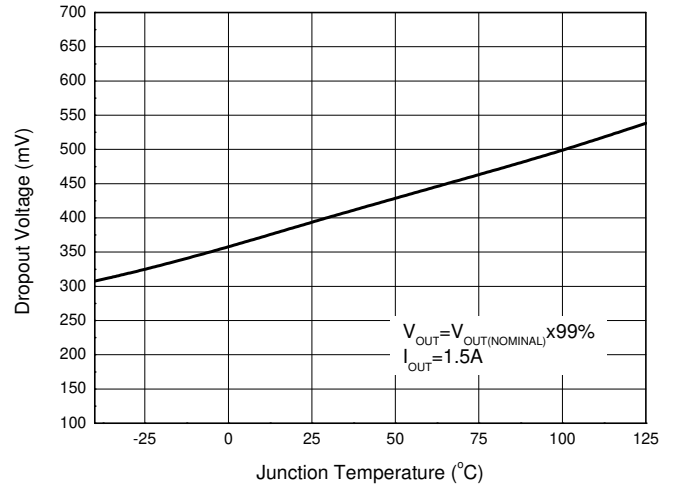

Output Voltage vs. Input Voltage

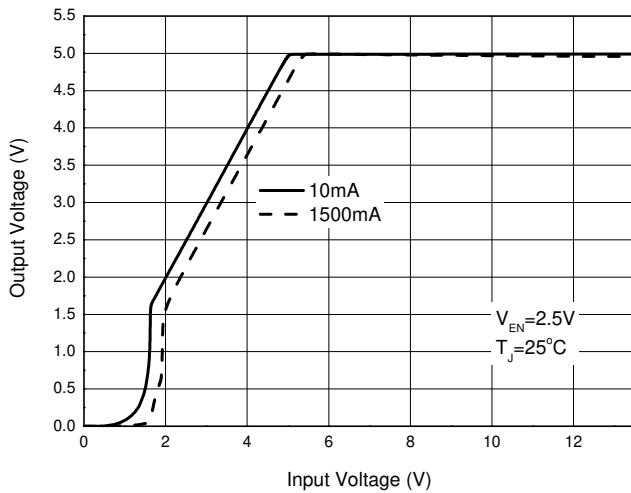

Ground Current vs. Input Voltage

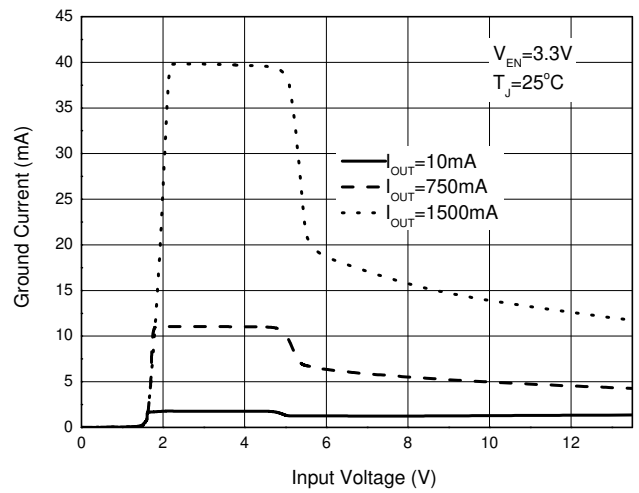

Ground Current vs. Output Current

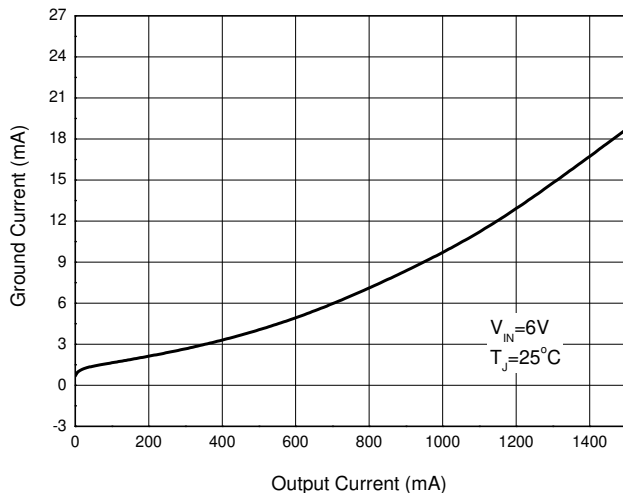

Ground Current vs. Junction Temperature

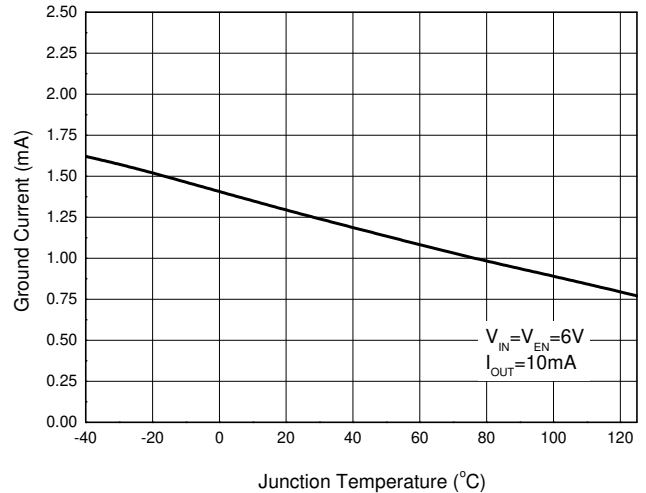

Performance Characteristics (Cont.)

Ground Current vs. Junction Temperature

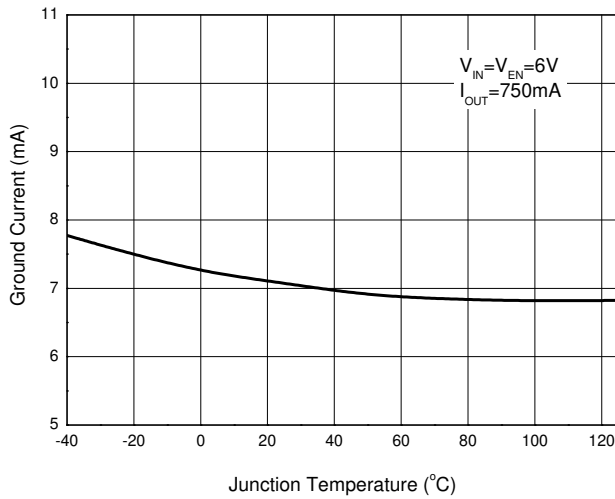

Ground Current vs. Junction Temperature

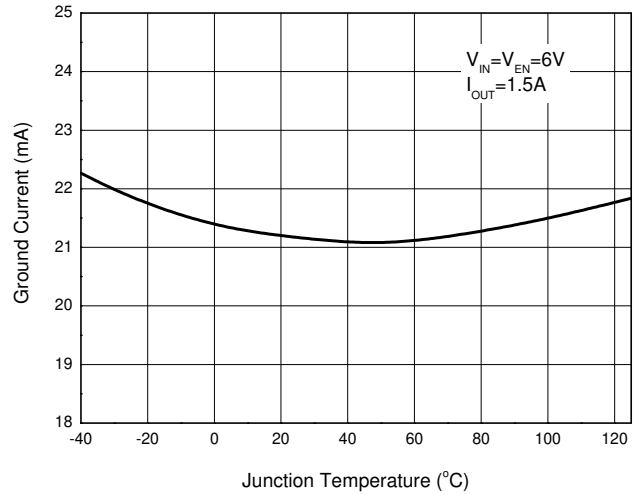

Short Circuit Current vs. Junction Temperature

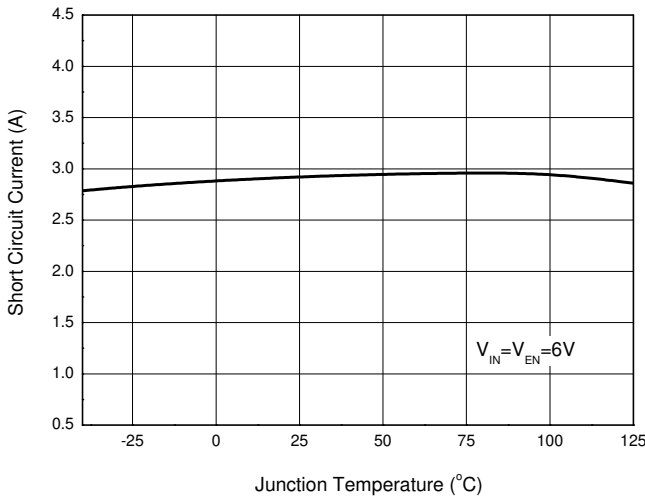

Output Voltage vs. Junction Temperature

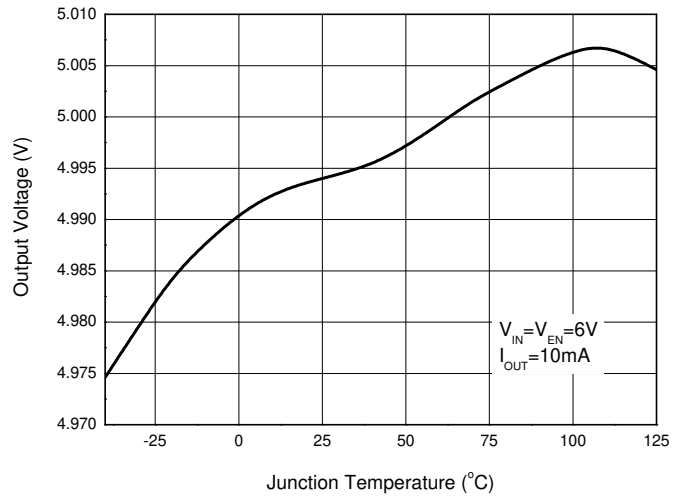

Enable Current vs. Junction Temperature

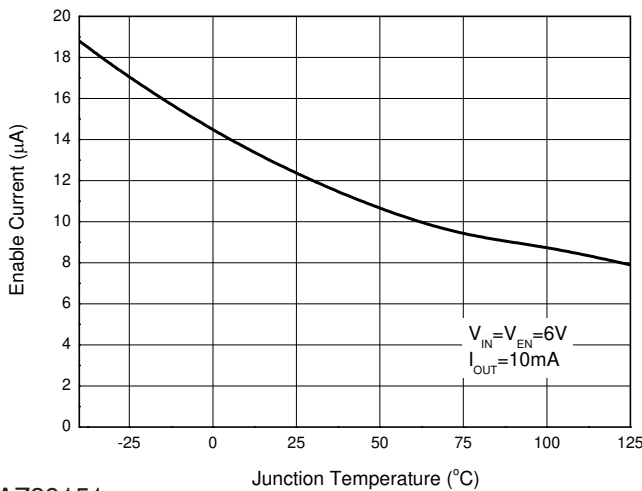

Line Transient
(Conditions: $V_{IN} = 5$ to $7V$, $I_{OUT} = 1.5A$, $C_{OUT} = 10\mu F$)

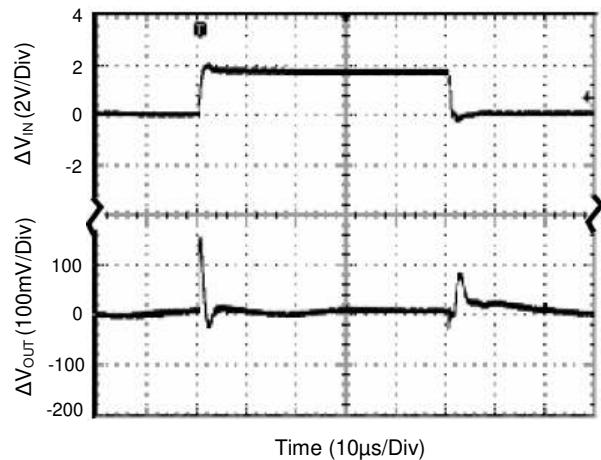

Performance Characteristics (Cont.)

Load Transient
(Conditions: $V_{IN} = 6V$, $I_{OUT} = 10mA$ to $1.5A$,
 $C_{IN} = C_{OUT} = 10\mu F$)

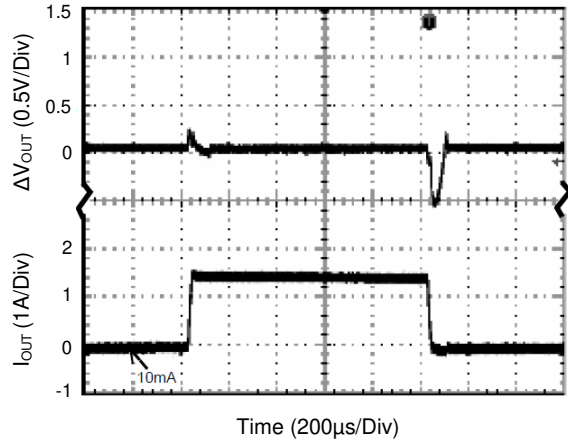

PSRR vs. Frequency
(Conditions: $V_{IN} = 6V$, $I_{OUT} = 10mA$,
 $C_{IN} = C_{OUT} = 10\mu F$)

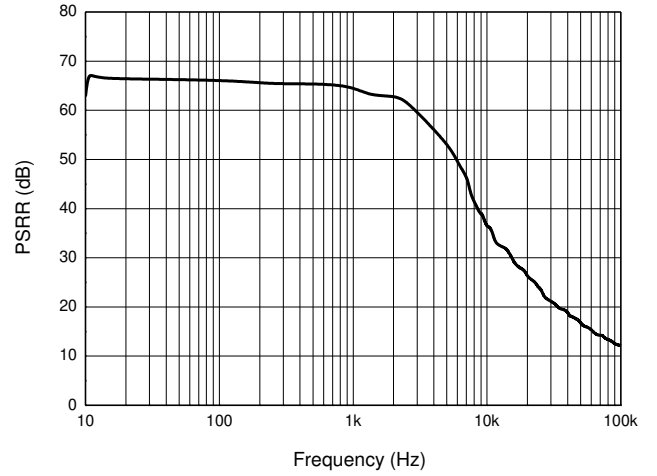

Ordering Information

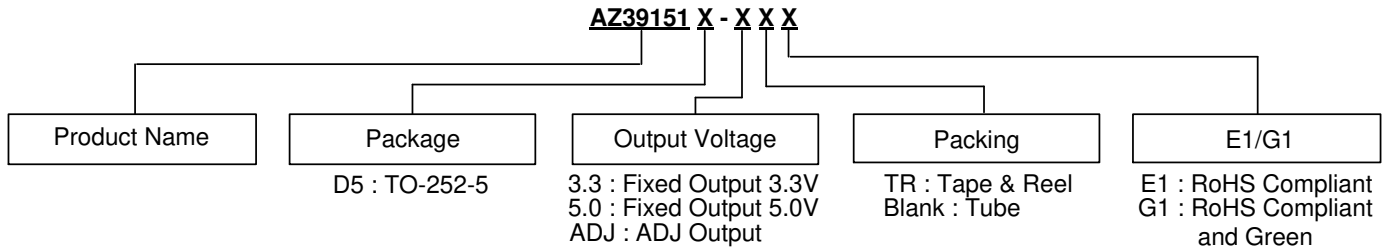

Package	Temperature Range	Part Number		Marking ID		Packing
		RoHS Compliant	RoHS Compliant and Green	RoHS Compliant	RoHS Compliant and Green	
TO-252-5	-40 to +125°C	AZ39151D5-3.3E1	AZ39151D5-3.3G1	AZ39151D5-3.3E1	AZ39151D5-3.3G1	Tube
		AZ39151D5-3.3TRE1	AZ39151D5-3.3TRG1	AZ39151D5-3.3E1	AZ39151D5-3.3G1	Tape & Reel
		AZ39151D5-5.0E1	AZ39151D5-5.0G1	AZ39151D5-5.0E1	AZ39151D5-5.0G1	Tube
		AZ39151D5-5.0TRE1	AZ39151D5-5.0TRG1	AZ39151D5-5.0E1	AZ39151D5-5.0G1	Tape & Reel
		AZ39151D5-ADJE1	AZ39151D5-ADJG1	AZ39151D5-ADJE1	AZ39151D5-ADJG1	Tube
		AZ39151D5-ADJTRE1	AZ39151D5-ADJTRG1	AZ39151D5-ADJE1	AZ39151D5-ADJG1	Tape & Reel

Package Outline Dimensions (All dimensions in mm(inch).)

(1) Package Type: TO-252-5

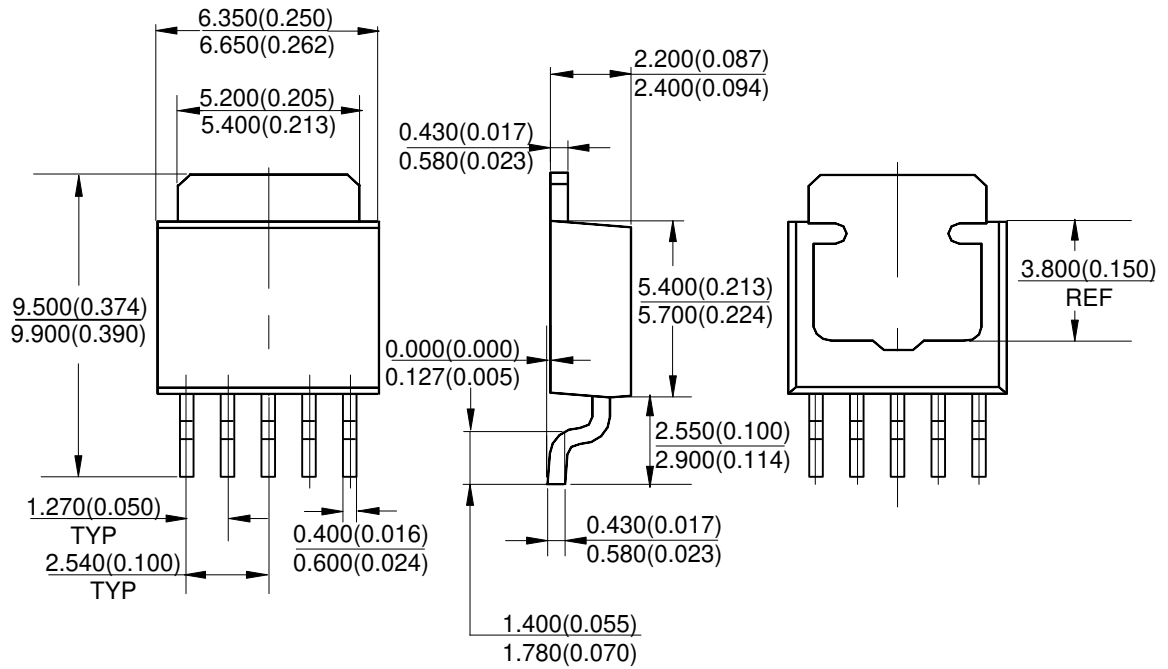

IMPORTANT NOTICE

DIODES INCORPORATED MAKES NO WARRANTY OF ANY KIND, EXPRESS OR IMPLIED, WITH REGARDS TO THIS DOCUMENT, INCLUDING, BUT NOT LIMITED TO, THE IMPLIED WARRANTIES OF MERCHANTABILITY AND FITNESS FOR A PARTICULAR PURPOSE (AND THEIR EQUIVALENTS UNDER THE LAWS OF ANY JURISDICTION).

Diodes Incorporated and its subsidiaries reserve the right to make modifications, enhancements, improvements, corrections or other changes without further notice to this document and any product described herein. Diodes Incorporated does not assume any liability arising out of the application or use of this document or any product described herein; neither does Diodes Incorporated convey any license under its patent or trademark rights, nor the rights of others. Any Customer or user of this document or products described herein in such applications shall assume all risks of such use and will agree to hold Diodes Incorporated and all the companies whose products are represented on Diodes Incorporated website, harmless against all damages.

Diodes Incorporated does not warrant or accept any liability whatsoever in respect of any products purchased through unauthorized sales channel. Should Customers purchase or use Diodes Incorporated products for any unintended or unauthorized application, Customers shall indemnify and hold Diodes Incorporated and its representatives harmless against all claims, damages, expenses, and attorney fees arising out of, directly or indirectly, any claim of personal injury or death associated with such unintended or unauthorized application.

Products described herein may be covered by one or more United States, international or foreign patents pending. Product names and markings noted herein may also be covered by one or more United States, international or foreign trademarks.

This document is written in English but may be translated into multiple languages for reference. Only the English version of this document is the final and determinative format released by Diodes Incorporated.

LIFE SUPPORT

Diodes Incorporated products are specifically not authorized for use as critical components in life support devices or systems without the express written approval of the Chief Executive Officer of Diodes Incorporated. As used herein:

A. Life support devices or systems are devices or systems which:

1. are intended to implant into the body, or
2. support or sustain life and whose failure to perform when properly used in accordance with instructions for use provided in the labeling can be reasonably expected to result in significant injury to the user.

B. A critical component is any component in a life support device or system whose failure to perform can be reasonably expected to cause the failure of the life support device or to affect its safety or effectiveness.

Customers represent that they have all necessary expertise in the safety and regulatory ramifications of their life support devices or systems, and acknowledge and agree that they are solely responsible for all legal, regulatory and safety-related requirements concerning their products and any use of Diodes Incorporated products in such safety-critical, life support devices or systems, notwithstanding any devices- or systems-related information or support that may be provided by Diodes Incorporated. Further, Customers must fully indemnify Diodes Incorporated and its representatives against any damages arising out of the use of Diodes Incorporated products in such safety-critical, life support devices or systems.

Copyright © 2018, Diodes Incorporated

www.diodes.com