

LOC	DIST	P	F	ZONE	LTR	DESCRIPTION	DATE	APPD
G	14				0	RELEASED PER PR 95-71	21AUG95	MJS

METRIC
 DIMENSIONS LISTED IN mm [INCHES]

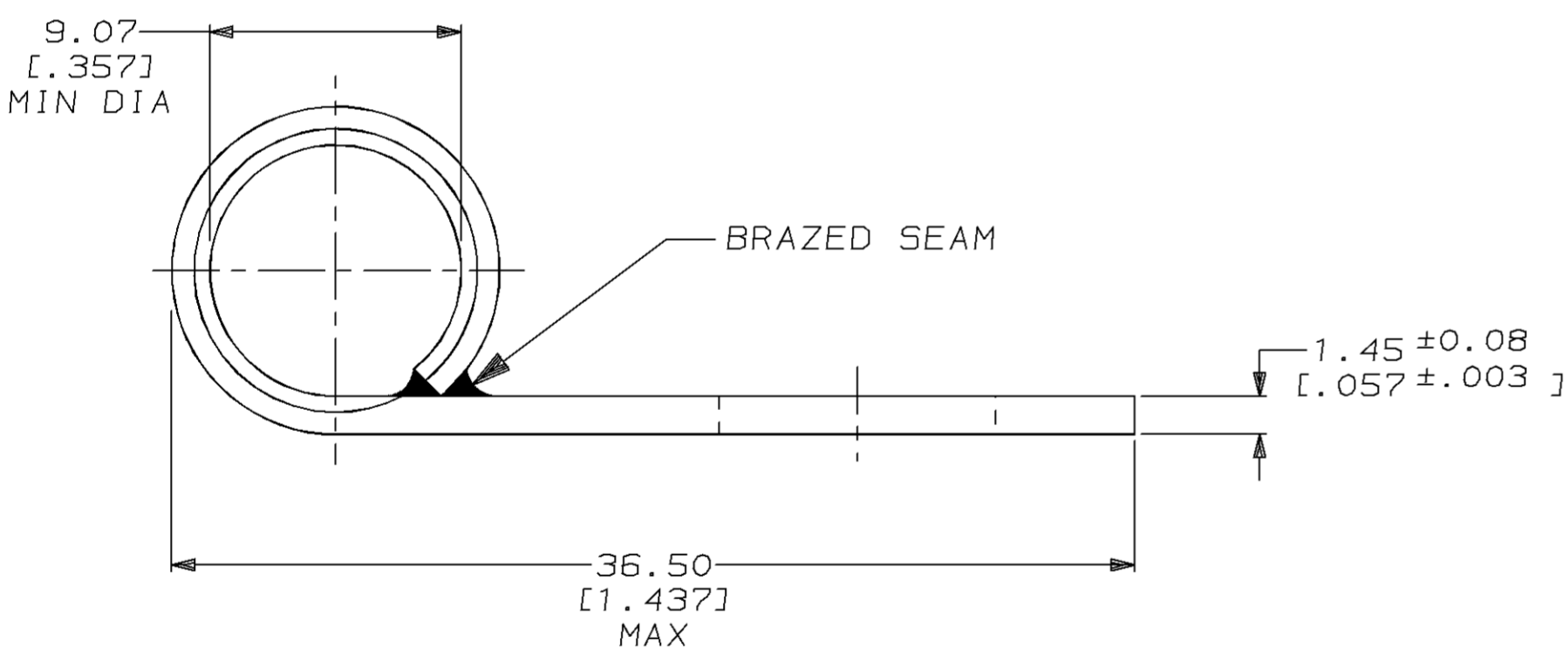
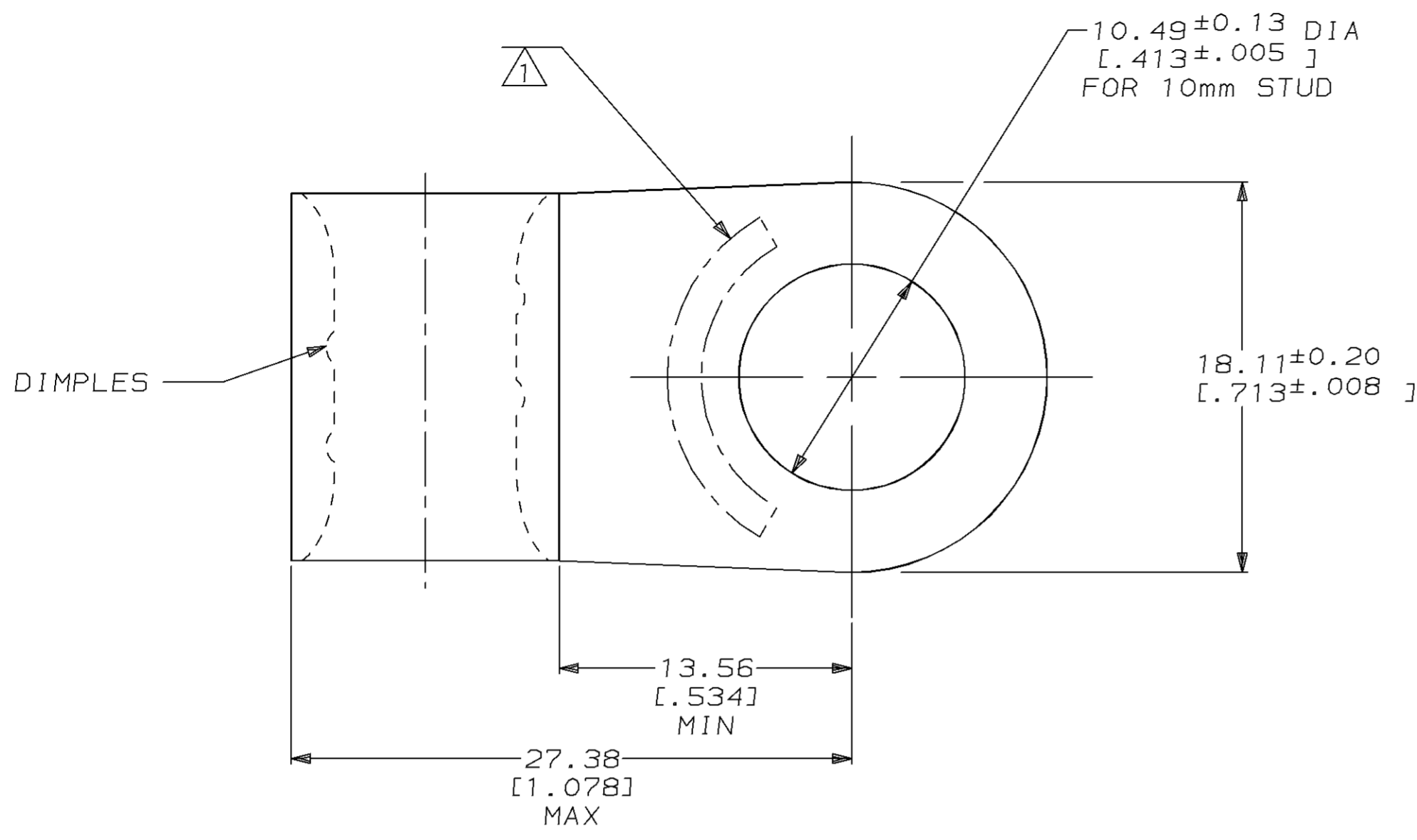

AMP WIRE RANGE	UL E13288 Listed
2 AWG SOLID OR STRANDED	PENDING
SR LR7189 Certified	MILITARY P/N AND CLASS
2 AWG SOLID OR STRANDED	NOT APPLICABLE

1 STAMP AMP 2W* APPROX AS SHOWN

AMP INCORPORATED CUSTOMER SERVICE SYSTEMS		MAX RECOMMENDED OPERATING TEMPERATURE: 170°C MAX	DO NOT SCALE PRINT. UNLESS SPECIFIED DIMENSIONS IN mm [INCHES] TOLERANCES ON: 2 PLC DEC ± 0.20 [.008] 3 PLC DEC ± - ANGLES ± -	DR 10AUG95 DK SCHRUM	AMP AMP Incorporated Harrisburg, PA 17105-3608			
FOR ADDITIONAL PRODUCT INFORMATION OR COPIES OF DRAWINGS AND TECHNICAL DOCUMENTS	PRODUCT INFORMATION CENTER 1-800-522-6752	VOLTAGE RATING: NOT APPLICABLE	MATERIAL COPPER PER ASTM B-152 ANNEALED	CHK 10AUG95 MJ SPICER	NAME TERMINAL, RING TONGUE, FLAG, SOLISTRAND™			
FOR APPLICATION TOOLING INFORMATION	TOOLING ASSISTANCE CENTER 1-800-722-1111	WIRE CROSS SECTIONAL AREA RANGE: 26.7-42.4mm² [52,600-83,700] CIR MILS SOLID OR STRANDED	FINISH TIN PLATE 0.00254 [.000100] MIN THK PER MIL-T-10727	APPD 10AUG95 CH KULYNYCH				
FOR ORDER ENTRY	1-800-526-5142	THIS DRAWING IS A CONTROLLED DOCUMENT FOR AMP INCORPORATED. IT IS SUBJECT TO CHANGE AND THE CONTROLLING ENGINEERING ORGANIZATION SHOULD BE CONTACTED FOR THE LATEST REVISION.		APPD 10AUG95 JL MECKLEY	PRODUCT SPEC -	SIZE C	CAGE CODE 00779	DRAWING NO C=184147
				APPLICATION SPEC -	WEIGHT -	SCALE 4:1	SHEET 1 OF 1	