

HMIK - SERIES

BUL86310

REV. A

ASSEMBLY INSTRUCTIONS FOR HME MAIN INTERLOCK KIT

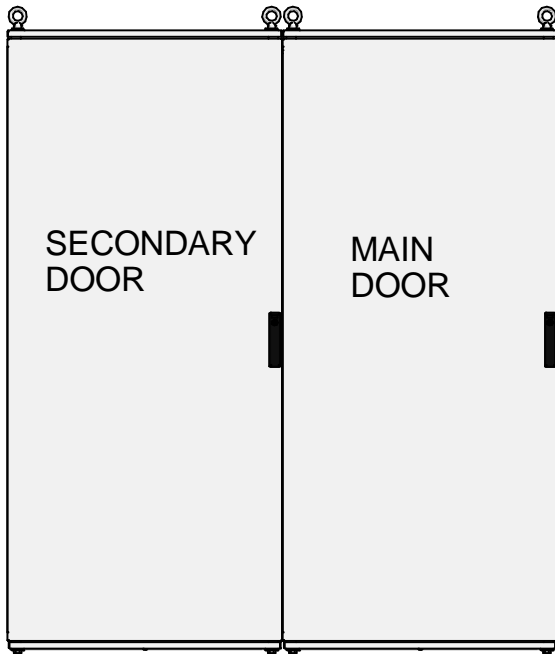

FRONT VIEW
(GANGED TOGETHER REFERENCE)

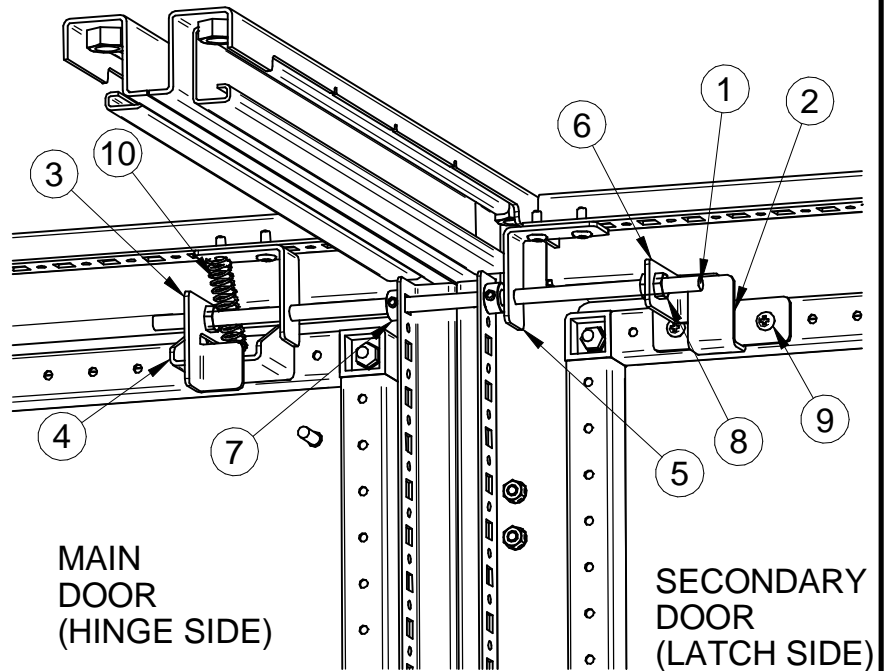

INSIDE ASSEMBLED VIEW

ITEM	DESCRIPTION	QTY
1	5/16-18 X 12" Threaded Rod	1
2	HME - interlock door catch	1
3	HME - interlock plunger	1
4	HME - interlock engager	1
5	HME - interlock rod support	2
6	HME - interlock catch	1
7	5/16 Shaft Collar Zp	2
8	Nut 5/16-18 Hex Jam ZP	4
9	Screw - #12 X 1/2" Pan head Phillips Self Tapping	9
10	Spring Util. Est Type 7/16 X 2	1

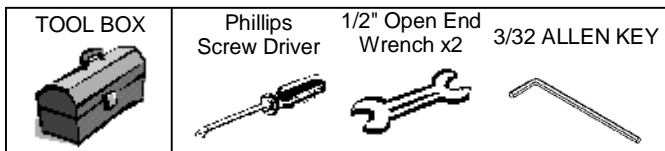

HMIK - SERIES

BUL86310

REV. A

ASSEMBLY INSTRUCTIONS FOR HME MAIN DOOR INTERLOCK KIT

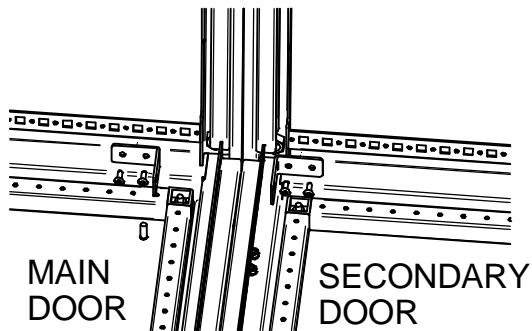

FIG. 1 (TOP INSIDE VIEW)

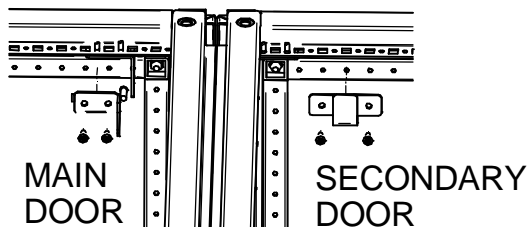

FIG. 2 (TOP INSIDE VIEW)

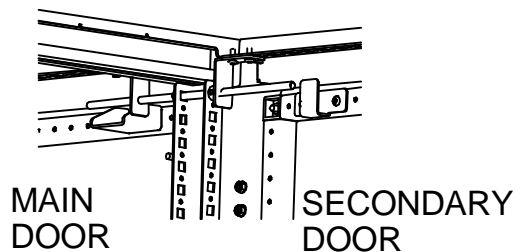

FIG. 3

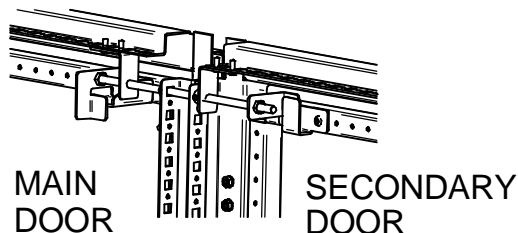

FIG. 4

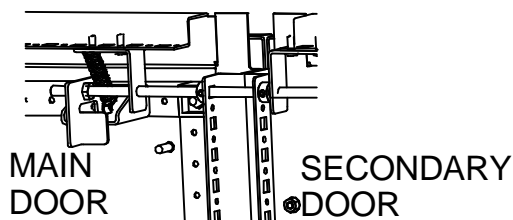

FIG. 5

INSTRUCTIONS:

A) Install interlock rod support brackets (Item 5), one on the main enclosure frame one on the secondary enclosure frame (fig 1) using thread rolling screws (Item 9). Make sure the bracket in the main enclosure will be close to where the interlock engager assembly will end up. The secondary enclosure bracket can go anywhere it doesn't interfere with the locking mechanism.

B) Install the interlock engager (Item 4) onto the main enclosure door frame and the interlock door catch (Item 2) onto the secondary enclosure door frame as shown in fig. 2 using thread rolling screws.

C) Feed threaded rod (Item 1) through the interlock rod supports (Item 5), the top square of the HME frame and the shaft collars (Item 7) as shown in fig. 3.

D) Thread on one jam nut (Item 8) onto each end of the threaded rod (Item 1). Install the interlock plunger (Item 3) onto the main HME side and center it on the interlock engager (Item 4). Thread on other jam nut and tighten down both nuts. Make sure the plunger is in the orientation shown in fig. 4.

E) Install the interlock catch (Item 6) as shown in fig.4 and lock down with a jam nut.

F) Remove one of the thread rolling screws holding on the rod support in the main HME. Re-install the screw with the spring (Item 10). Attach other end of the spring to the interlock plunger (Item 3) using a thread rolling screw (Item 9).

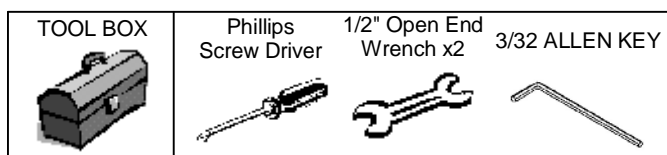

**HAMMOND
MANUFACTURING™**
www.hammondmfg.com