

HIP6006/7EVAL1

DC-DC Converters for Microprocessors with Fixed Core Voltage Requirements

AN9722
Rev.0.00
Apr 1997

Introduction

Today's high-performance microprocessors present many challenges to their power source. High power consumption, low bus voltages, and fast load changes are the principal characteristics which have led to the need for a switch-mode DC-DC converter local to the microprocessor.

Intel has specified Voltage Regulator Modules (VRMs) for the Pentium Pro and Pentium II microprocessors [1]. These specifications detail the requirements imposed upon the input power source(s) by the Pentium Pro and Pentium II and provide the computer industry with standard DC-DC converter solutions. A common requirement of these and similar processors are decreasing supply voltages as the processor clock frequency increases.

The Intersil HIP6002-5 pulse-width modulator (PWM) controllers are targeted specifically for DC-DC converters powering the Pentium Pro, Pentium II, and other high-performance microprocessors with varying core voltage requirements. The HIP6002 and HIP6003 have a 4-bit digital to analog converter (DAC) and the HIP6004-5 have a 5-bit DAC to address the 'moving target' processor core voltage.

The HIP6006 and HIP6007 use the same basic architecture of the HIP6002-5, but have a reduced feature set. One feature removed is the DAC, which allows the HIP6006 and HIP6007 to be packaged in a smaller 14 lead SOIC. These chips provide cost-effective solutions for point-of-use switch-mode DC-DC converters for many applications. This application note details the HIP6006 and HIP6007 in DC-DC converters for high-performance microprocessors with a fixed core voltage.

Intersil HIP6006 and HIP6007

The Intersil HIP6006 and HIP6007 are voltage-mode controllers with many functions needed for high-performance processors. Figure 1 shows a simple block diagram of the HIP6006 and HIP6007. Each contains a high-performance error amplifier, a high-accuracy reference, a programmable free-running oscillator, and overcurrent protection circuitry. The HIP6006 has two MOSFET drivers for use in synchronous-rectified Buck converters. The HIP6007 omits the lower MOSFET driver for standard Buck configurations. A more complete description of the parts can be found in their data sheets [2, 3].

HIP6006/7 Reference Designs

The HIP6006/7EVAL1 is an evaluation board which highlights the operation of the HIP6006 or the HIP6007 in an embedded motherboard application. The evaluation board can be configured as either a synchronous Buck (HIP6006EVAL1) or standard Buck (HIP6007EVAL1) converter.

HIP6006EVAL1

The HIP6006EVAL1 is a synchronous Buck converter capable of providing up to 9A of current at a fixed 2.5V output voltages. Simple resistor value changes allow for outputs as low as 1.3V. The schematic and bill-of-materials for this design can be found in the appendix.

Efficiency

Figure 2 displays the HIP6006EVAL1 efficiency versus load current for both 5V and 12V inputs with 100 linear feet per minute (LFM) of airflow. For a given output voltage and load, the efficiency is lower at higher input voltages. This is due primarily to higher MOSFET switching losses and is displayed in Figure 2.

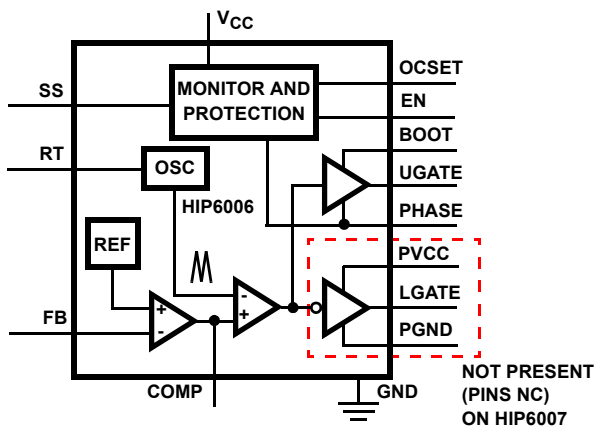

FIGURE 1. BLOCK DIAGRAM OF HIP6006 AND HIP6007

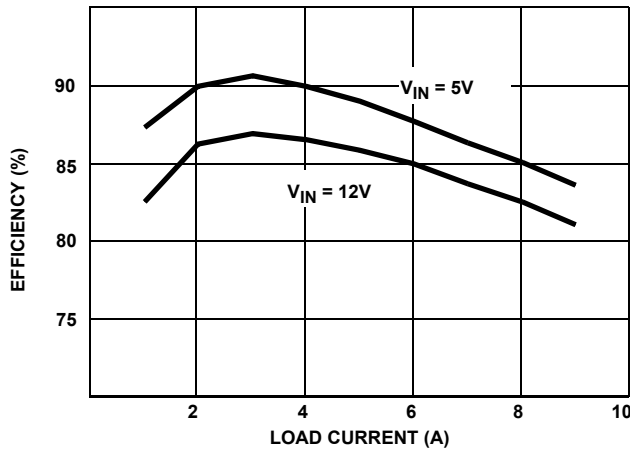

FIGURE 2. HIP6006EVAL1 EFFICIENCY vs LOAD

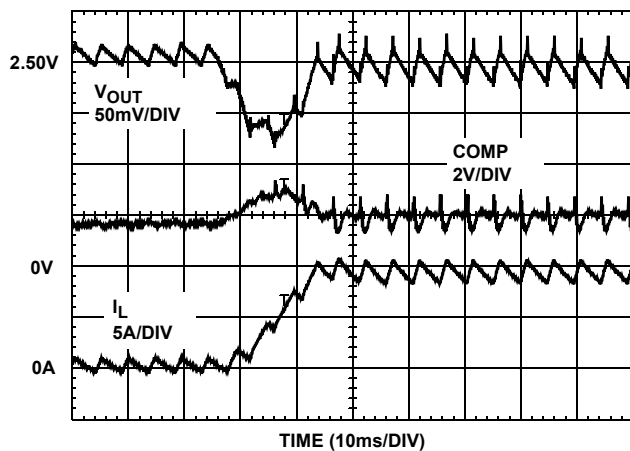

FIGURE 3. HIP6006EVAL1 TRANSIENT RESPONSE WITH $V_{IN} = 12V$

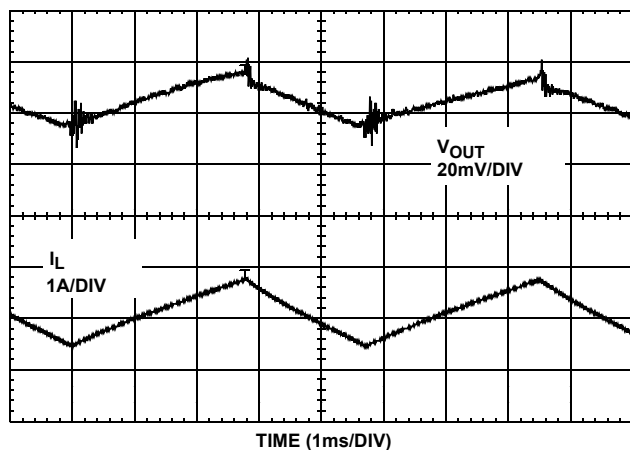

FIGURE 4. HIP6006EVAL1 OUTPUT VOLTAGE RIPPLE

Transient Response

Figure 3 shows a laboratory oscilloscope of the HIP6006EVAL1 in response to a 0-9A load transient application. The output voltage responds rapidly and is within 1% of its nominal value in less than 15 μ s.

Output Voltage Ripple

The output voltage ripple and inductor current of the HIP6006EVAL1 is shown in Figure 4. The input voltage is 5V and the load current is 9A for this oscilloscope. Peak-to-peak voltage ripple is about 20mV under these conditions.

HIP6007EVAL1

The HIP6007EVAL1 is a standard Buck converter capable of providing up to 9A of current. The schematic and bill-of-materials for this design can be found in the appendix. The HIP6007EVAL1 differs from the HIP6006EVAL1 in four ways:

1. U1 is a HIP6007
2. CR3 replaces Q2 and CR2
3. Jumper JP1 is added
4. L1 is a larger inductor

JP1 is needed because CR3 is a dual, common-cathode device and it is replacing a MOSFET. JP1 connects one device's anode (the MOSFET gate in the HIP6006EVAL1) to ground. The other anode and the common cathode replace the MOSFET source and drain respectively.

Efficiency

Figure 5 shows the efficiency data for the HIP6007EVAL1 under identical conditions as Figure 2 for the HIP6006EVAL1. Comparing the two graphs reveals that the Synchronous-Buck design is a little more efficient than the Standard-Buck design over most of the load range.

Transient Response

Figure 6 shows a laboratory oscilloscope of the HIP6007EVAL1 in response to a 0-9A load transient application. The output voltage responds a little slower than the HIP6006EVAL1, but still is within 1% of its nominal value in less than 25ms. Since the HIP6007EVAL1 uses a larger output inductor and identical control loop compensation (R3, R5, C14, and C15), the closed-loop gain crossover frequency is lower than for the HIP6006EVAL1. Check the Feedback Compensation section of either data sheet for details on loop compensation design. Table 1 details simulated closed-loop bandwidth and phase margin for both reference boards at both +5V and +12V input sources.

TABLE 1. CONTROL LOOP CHARACTERISTICS

	HIP6006EVAL1		HIP6007EVAL1	
	$V_{IN} = 5V$	$V_{IN} = 12V$	$V_{IN} = 5V$	$V_{IN} = 12V$
f_{0dB}	27KHz	61KHz	12KHz	28KHz
ϕ MARGIN	72°	62°	68°	71°

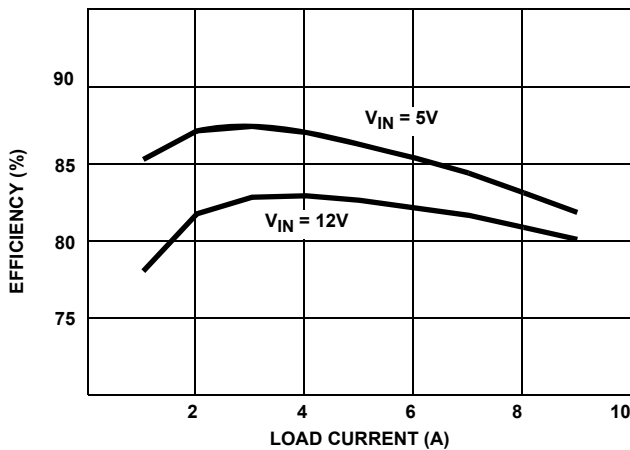

FIGURE 5. HIP6007EVAL1 EFFICIENCY vs LOAD

FIGURE 6. HIP6007EVAL1 TRANSIENT RESPONSE
WITH $V_{IN} = 12V$ 

FIGURE 7. HIP6007EVAL1 OUTPUT VOLTAGE RIPPLE

Output Voltage Ripple

The output voltage ripple and inductor current of the HIP6007EVAL1 is shown in Figure 7. The input voltage is 5V and the load current is 9A for this oscillogram. Peak-to-peak voltage ripple is less than that for the HIP6006EVAL1 (about 15mV), since the output inductor is larger.

OC Protection

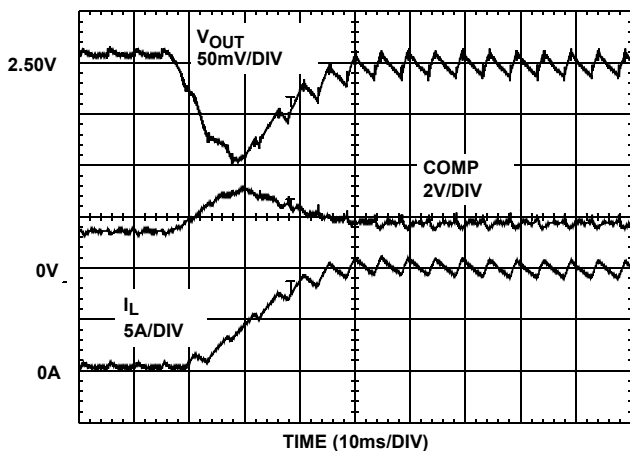
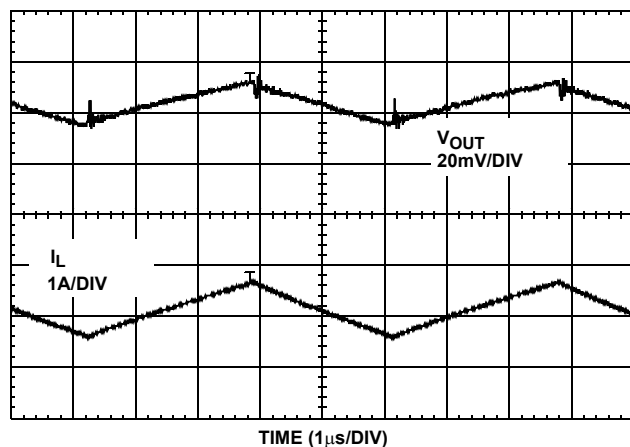
Both the HIP6006EVAL1 and HIP6007EVAL1 have lossless overcurrent (OC) protection. This is accomplished via the current-sense function of the HIP600x family. The HIP6006 and HIP6007 sense converter load current by monitoring the drop across the upper MOSFET (Q1 in the schematics). By selecting the appropriate value of the OCSET resistor (R6), an overcurrent protection scheme is employed without the cost and power loss associated with an external current-sense resistor. See the *Over-Current Protection* section of either the HIP6006 and HIP6007 data sheet for details on the design procedure for the OCSET resistor.

Customization of Reference Designs

The HIP6006EVAL1 and HIP6007EVAL1 reference designs are solutions for Pentium-class microprocessors with current demands of up to 9A. The two designs share much common circuitry and the same printed circuit board. Other than the four items listed under the *HIP6007EVAL1* section, one basic design is employed to meet many different applications. The evaluation boards can be powered from +5V or +12V and a standard Buck or a synchronous Buck topology may be employed. Employing one basic design for numerous applications involves some trade-offs. These trade-offs are discussed below to help the user optimize for a given application.

Control Loop Bandwidth/Transient Response

Table 1 shows how the control loop characteristics vary with line voltage and topology. The line voltage determines the amount of DC gain, which directly affects the modulator (control-to-output) transfer function. The topology (standard buck or synchronous buck) is important because we have chosen to use a larger output inductor for the standard buck (HIP6005) design. This lowers the boundary of continuous conduction mode (ccm) and discontinuous conduction mode (dcm) operation. Staying in ccm at light loads can have an adverse affect on transient response of the converter. The HIP6006EVAL1 design will not go into dcm operation because the lower MOSFET conducts current even at light or zero load conditions.

From Table 1, we see that the highest control loop bandwidth is the HIP6006EVAL1 with $V_{IN} = 12V$. The transient response of the converter for this case is shown in Figure 3. The other three cases have slower responding loops and can be improved with value changes in the compensation components. Table 2 details suggested changes and the improved control loop characteristics for the three applications with slower control loops.

TABLE 2. MODIFICATIONS TO CONTROL LOOP

	HIP6006EVAL1		HIP6007EVAL1	
	V _{IN} = 5V	V _{IN} = 12V	V _{IN} = 5V	V _{IN} = 12V
R5	30.1K	no change	80.6K	30.1K
C14	no change	no change	10p	no change
f _{0dB}	47kHz	61kHz	44kHz	48kHz
Φ _{MARGIN}	53°	62°	40°	52°

Ripple Voltage

The amount of ripple voltage on the output of the DC-DC converter varies with input voltage, switching frequency, output inductor, and output capacitors. For a fixed switching frequency and output filter, the voltage ripple increases with higher input voltage. The ripple content of the output voltage can be estimated with the following simple equation:

$$\Delta V_{OUT} = \Delta I_L \cdot ESR$$

where

$$\Delta I_L = \frac{(V_{IN} - V_{OUT}) \cdot \frac{V_{OUT}}{V_{IN}} \cdot T_s}{L_{OUT}}$$

ESR = equivalent series resistance of output capacitors

T_s = switching period (1/F_s)

L_{OUT} = output inductance

Therefore, for equivalent output ripple performance at V_{IN} = 12V as at 5V, the output filter or switching frequency must change. Assuming 200KHz operation is desired, either the output inductor value should increase or the number of parallel output capacitors should increase (to decrease the effective ESR).

Increased Output Power Capability

The HIP6006/7EVAL1 printed circuit board is laid out with flexibility to increase the power level of the DC-DC converter beyond 9A. Locations for additional input capacitors and output capacitors are provided. In conjunction with higher current MOSFETs, Schottky rectifiers, and inductors, the evaluation board can be tailored for applications requiring upwards of 15A. The HIP6006 and HIP6007 data sheets' Component Selection Guidelines sections help the user with the design issues for these applications. Of course, the HIP6006/7EVAL1 can be modified for more cost-effective solutions at lower currents as well.

MOSFET Selection

As a supplement to the data sheets' application information on MOSFET Selection Considerations, this section shows graphically that a larger, lower r_{DS(ON)} MOSFET does not always improve converter efficiency. Figure 8 shows that smaller RFP25N05 MOSFETs are more efficient over most of the line and load range than larger RFP45N06 MOSFETs. The

RFP25N05 (used on the HIP6006/7EVAL1) has a r_{DS(ON)} equal to 47mΩ (maximum at 25°C) versus 28mΩ for the RFP45N06. In comparison to the RFP25N05, the RFP45N06 MOSFETs increased switching losses are greater than its decreased conduction losses at load currents up to about 7A with a 5V input and about 9A with a 12V input.

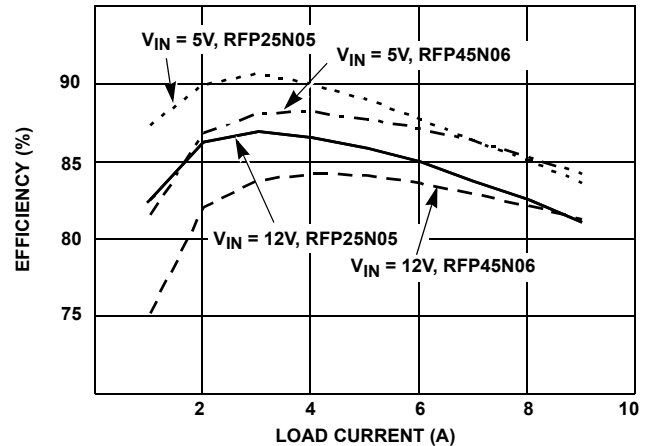

FIGURE 8. HIP6006EVAL1 EFFICIENCY WITH EITHER RFP25N05 MOSFETs OR RFP45N06 MOSFETs

Conclusion

The HIP6006EVAL1 and HIP6007EVAL1 are DC-DC converters reference designs for microprocessors with fixed core voltages and current requirements of up to 9A. In addition, the designs can be modified for applications with different requirements. The printed circuit board is laid out to accommodate the necessary components for operation at currents up to 15A.

References

For Intersil documents available on the web, see <http://www.intersil.com/>

- [1] *Pentium-Pro Processor Power Distribution Guidelines*, Intel Application Note AP-523, November, 1995.
- [2] *HIP6006 Data Sheet*, Intersil Corporation, Doc. No. 4306.
- [3] *HIP6007 Data Sheet*, Intersil Corporation, Doc. No. 4307.

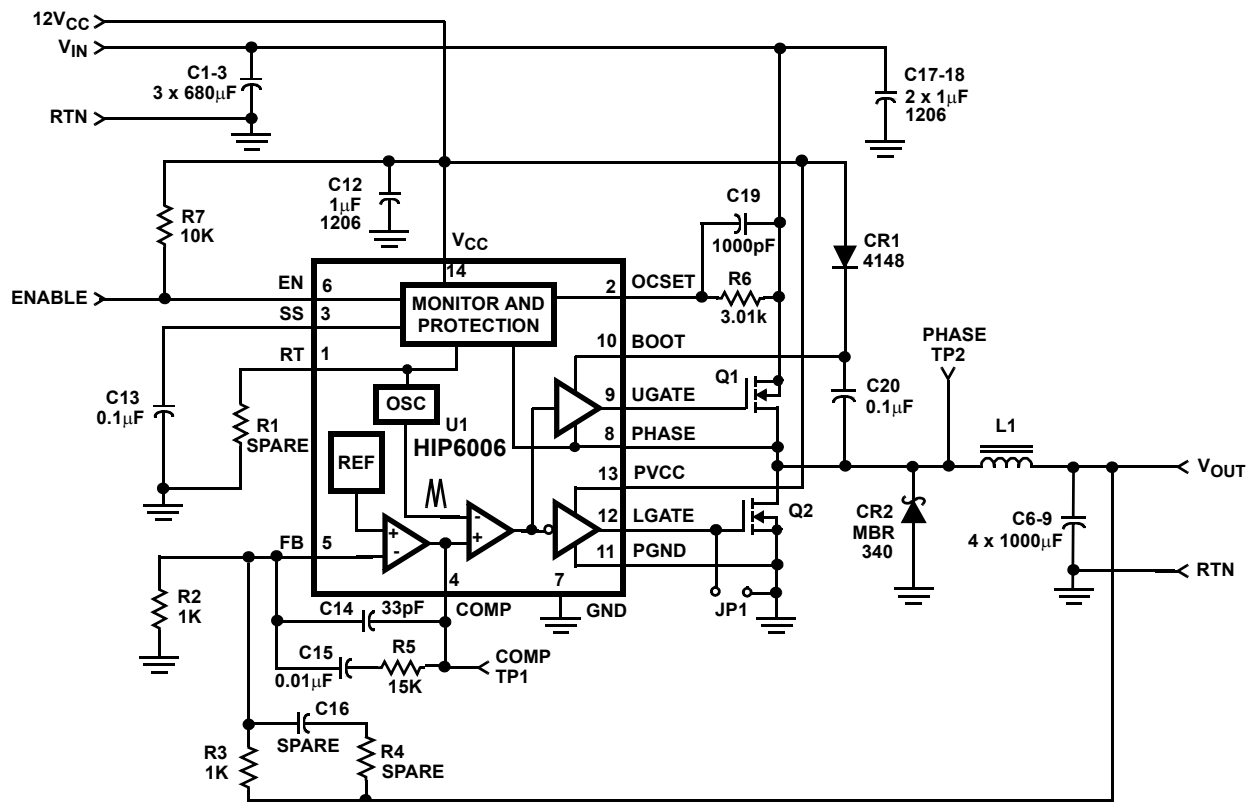

FIGURE 9. HIP6006EVAL1 SCHEMATIC

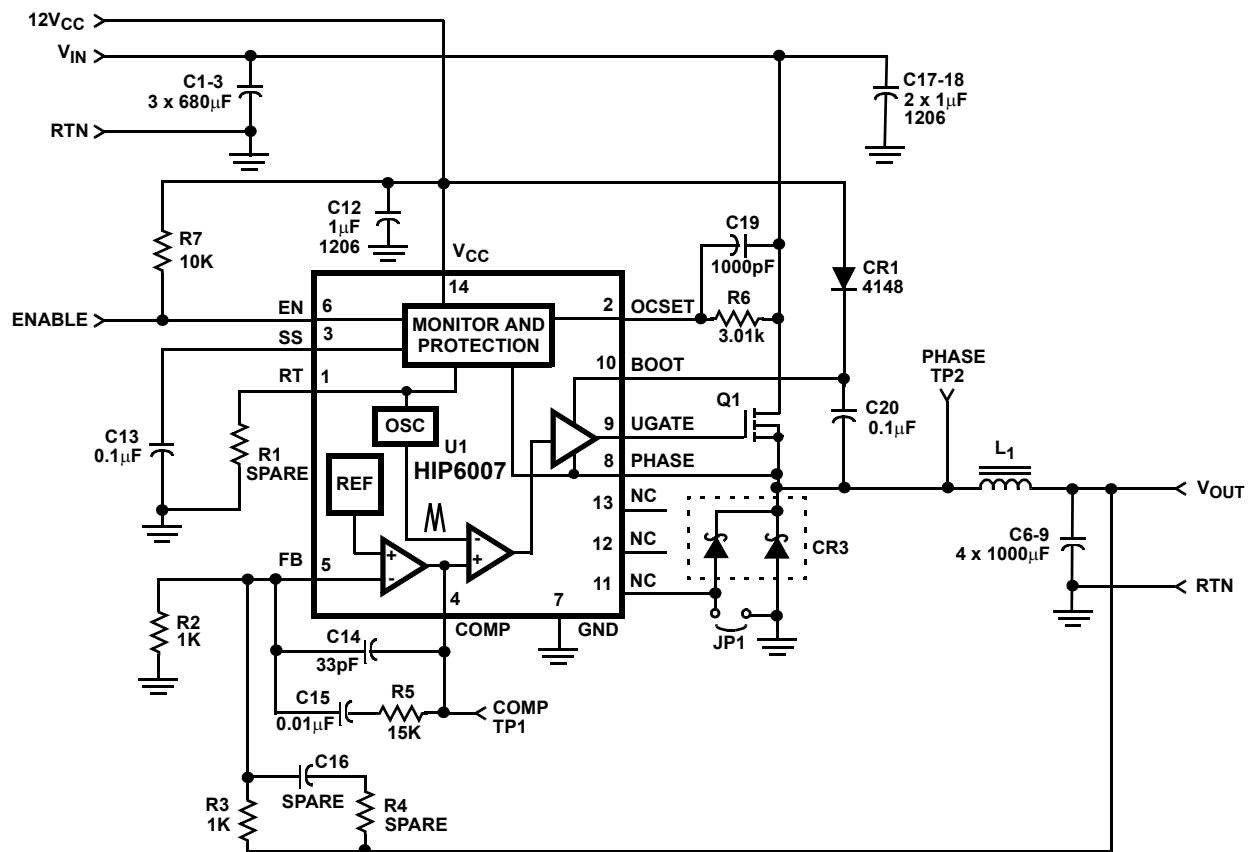

FIGURE 10. HIP6007EVAL1 SCHEMATIC

Bill of Materials for HIP6006EVAL1

PART NUMBER	DESCRIPTION	PACKAGE	QTY	REF	VENDOR
25MV680GX	680 μ F, 25V Aluminum Capacitor	Radial 10 x 22	3	C1 - C3	Sanyo
6MV1000GX	1000 μ F, 6.3V Aluminum Capacitor	Radial 8 x 20	4	C6 - C9	Sanyo
1206YZ105MAT1A	1.0 μ F, 16V, X7S Ceramic Capacitor	1206	3	C12, C17-C18	AVX
1000pF Ceramic	1nF, X7R Ceramic Capacitor	0805	1	C19	Various
0.1uF Ceramic	0.1 μ F, 25V X7R Ceramic Capacitor	0805	2	C13, C20	AVX/Panasonic
0.01uF Ceramic	0.01 μ F, X7R Ceramic Capacitor	0805	1	C15	Various
33pF Ceramic	33pF, X7R Ceramic Capacitor	0805	1	C14	Various
Spare	Spare Ceramic Capacitor	0805		C16	
1N4148	Rectifier 75V	DO35	1	CR1	Various
MBR340	3A, 40V, Schottky	Axial	1	CR2	Motorola
CTX09-13313-X1 PO343	5.3 μ H, 12A Inductor T50-52B Core, 10 Turns of 16 AWG Wire	Wound Toroid	1	L1	Coiltronics Pulse
RFP25N05	47m Ω , 50V MOSFET	TO220	2	Q1, Q2	Intersil
HIP6006	Synchronous Rectified Buck Controller	SOIC-14	1	U1	Intersil
10k Ω	10k Ω , 5% 0.1W, Resistor	0805	1	R7	Various
Spare	Spare 0.1W, Resistor	0805		R1,R4	
15k Ω	15k Ω , 5%, 0.1W, Resistor	0805	1	R5	Various
1k Ω	1k Ω , 5%, 0.1W, Resistor	0805	2	R2-R3	Various
3.01k Ω	3.01k Ω , 1%, 0.1W, Resistor	0805	1	R6	Various
576802B00000	TO-220 Clip-on Heatsink		2		AAVID
1514-2	Terminal Post		6	V _{IN} , 12V _{CC} , V _{OUT} , RTN	Keystone
1314353-00	Scope Probe Test Point		1	V _{OUT}	Tektronics
SPCJ-123-01	Test Point		3	ENABLE, TP1, TP2	Jolo

Bill of Materials for HIP6007EVAL1

PART NUMBER	DESCRIPTION	PACKAGE	QTY	REF	VENDOR
25MV680GX	680 μ F, 25V Aluminum Capacitor	Radial 10 x 22	3	C1 - C3	Sanyo
6MV1000GX	1000 μ F, 6.3V Aluminum Capacitor	Radial 8 x 20	4	C6 - C9	Sanyo
1206YZ105MAT1A	1.0 μ F, 16V, X7S Ceramic Capacitor	1206	3	C12, C17-C18	AVX
1000pF Ceramic	1nF, X7R Ceramic Capacitor	0805	1	C19	Various
0.1 μ F Ceramic	0.1 μ F, 25 V X7R Ceramic Capacitor	0805	2	C13, C20	AVX/Panasonic
0.01 μ F Ceramic	0.01 μ F, X7R Ceramic Capacitor	0805	1	C15	Various
33pF Ceramic	33pF, X7R Ceramic Capacitor	0805	1	C14	Various
Spare	Spare Ceramic Capacitor	0805		C16	
1N4148	Rectifier 75V	DO35	1	CR1	Various
MBR1535CT	15A, 35V, Schottky	TO220	1	CR3	Motorola
CTX09-13337-X1 PO345	7 μ H, 12A Inductor T60-52 Core, 14 turns of 17 AWG wire	Wound Toroid	1	L1	Coiltronics Pulse
RFP25N05	47m Ω , 50V MOSFET	TO220	1	Q1	Intersil
HIP6007	Synchronous Rectified Buck Controller	SOIC-14	1	U1	Intersil
10k Ω	10k Ω , 5%, 0.1W, Resistor	0805	1	R7	Various
Spare	Spare 0.1W, Resistor	0805		R1, R4	
15k Ω	15k Ω , 5%, 0.1W, Resistor	0805	1	R5	Various
1k Ω	1k Ω , 5%, 0.1W, Resistor	0805	2	R2-R3	Various
3.01k Ω	3.01k Ω , 1%, 0.1W, Resistor	0805	1	R6	Various
576802B00000	TO-220 Clip-on Heatsink		2		AAVID
1514-2	Terminal Post		6	V _{IN} , 12V _{CC} , V _{OUT} , RTN	Keystone
1314353-00	Scope Probe Test Point		1	V _{OUT}	Tektronics
SPCJ-123-01	Test Point		3	ENABLE, TP1, TP2	Jolo

TOP
SILK SCREEN

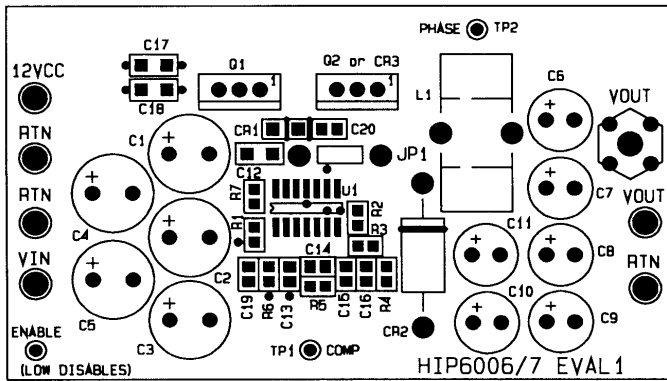

INT. GND. PLANE

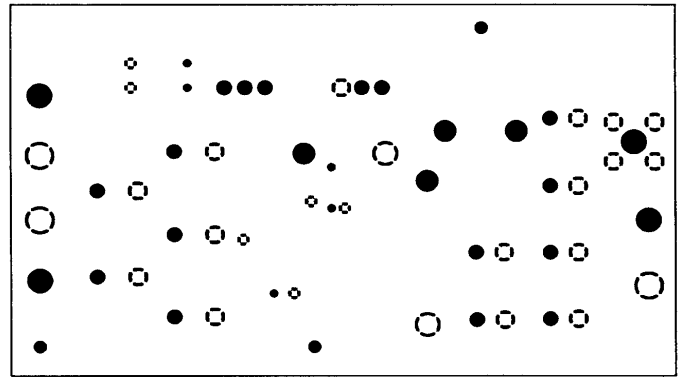

COMPONENT SIDE

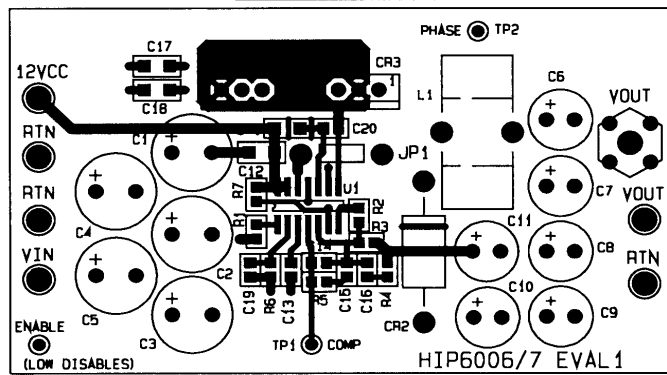

INTERNAL ONE

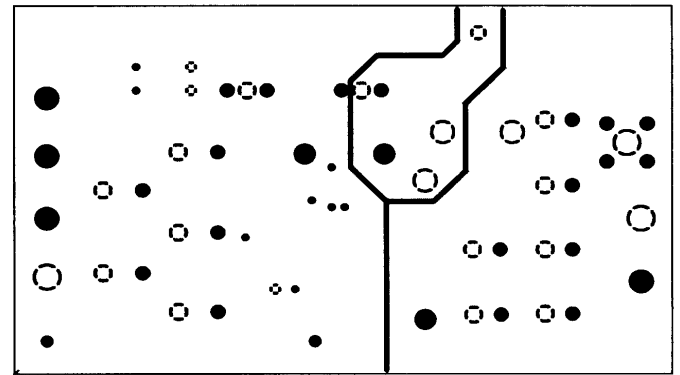

SOLDER SIDE

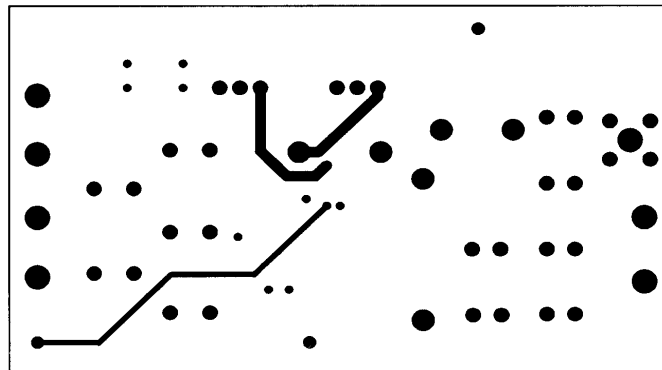

Notice

1. Descriptions of circuits, software and other related information in this document are provided only to illustrate the operation of semiconductor products and application examples. You are fully responsible for the incorporation or any other use of the circuits, software, and information in the design of your product or system. Renesas Electronics disclaims any and all liability for any losses and damages incurred by you or third parties arising from the use of these circuits, software, or information.
2. Renesas Electronics hereby expressly disclaims any warranties against and liability for infringement or any other claims involving patents, copyrights, or other intellectual property rights of third parties, by or arising from the use of Renesas Electronics products or technical information described in this document, including but not limited to, the product data, drawings, charts, programs, algorithms, and application examples.
3. No license, express, implied or otherwise, is granted hereby under any patents, copyrights or other intellectual property rights of Renesas Electronics or others.
4. You shall not alter, modify, copy, or reverse engineer any Renesas Electronics product, whether in whole or in part. Renesas Electronics disclaims any and all liability for any losses or damages incurred by you or third parties arising from such alteration, modification, copying or reverse engineering.
5. Renesas Electronics products are classified according to the following two quality grades: "Standard" and "High Quality". The intended applications for each Renesas Electronics product depends on the product's quality grade, as indicated below.
"Standard": Computers; office equipment; communications equipment; test and measurement equipment; audio and visual equipment; home electronic appliances; machine tools; personal electronic equipment; industrial robots; etc.
"High Quality": Transportation equipment (automobiles, trains, ships, etc.); traffic control (traffic lights); large-scale communication equipment; key financial terminal systems; safety control equipment; etc.
Unless expressly designated as a high reliability product or a product for harsh environments in a Renesas Electronics data sheet or other Renesas Electronics document, Renesas Electronics products are not intended or authorized for use in products or systems that may pose a direct threat to human life or bodily injury (artificial life support devices or systems; surgical implantations; etc.), or may cause serious property damage (space system; undersea repeaters; nuclear power control systems; aircraft control systems; key plant systems; military equipment; etc.). Renesas Electronics disclaims any and all liability for any damages or losses incurred by you or any third parties arising from the use of any Renesas Electronics product that is inconsistent with any Renesas Electronics data sheet, user's manual or other Renesas Electronics document.
6. When using Renesas Electronics products, refer to the latest product information (data sheets, user's manuals, application notes, "General Notes for Handling and Using Semiconductor Devices" in the reliability handbook, etc.), and ensure that usage conditions are within the ranges specified by Renesas Electronics with respect to maximum ratings, operating power supply voltage range, heat dissipation characteristics, installation, etc. Renesas Electronics disclaims any and all liability for any malfunctions, failure or accident arising out of the use of Renesas Electronics products outside of such specified ranges.
7. Although Renesas Electronics endeavors to improve the quality and reliability of Renesas Electronics products, semiconductor products have specific characteristics, such as the occurrence of failure at a certain rate and malfunctions under certain use conditions. Unless designated as a high reliability product or a product for harsh environments in a Renesas Electronics data sheet or other Renesas Electronics document, Renesas Electronics products are not subject to radiation resistance design. You are responsible for implementing safety measures to guard against the possibility of bodily injury, injury or damage caused by fire, and/or danger to the public in the event of a failure or malfunction of Renesas Electronics products, such as safety design for hardware and software, including but not limited to redundancy, fire control and malfunction prevention, appropriate treatment for aging degradation or any other appropriate measures. Because the evaluation of microcomputer software alone is very difficult and impractical, you are responsible for evaluating the safety of the final products or systems manufactured by you.
8. Please contact a Renesas Electronics sales office for details as to environmental matters such as the environmental compatibility of each Renesas Electronics product. You are responsible for carefully and sufficiently investigating applicable laws and regulations that regulate the inclusion or use of controlled substances, including without limitation, the EU RoHS Directive, and using Renesas Electronics products in compliance with all these applicable laws and regulations. Renesas Electronics disclaims any and all liability for damages or losses occurring as a result of your noncompliance with applicable laws and regulations.
9. Renesas Electronics products and technologies shall not be used for or incorporated into any products or systems whose manufacture, use, or sale is prohibited under any applicable domestic or foreign laws or regulations. You shall comply with any applicable export control laws and regulations promulgated and administered by the governments of any countries asserting jurisdiction over the parties or transactions.
10. It is the responsibility of the buyer or distributor of Renesas Electronics products, or any other party who distributes, disposes of, or otherwise sells or transfers the product to a third party, to notify such third party in advance of the contents and conditions set forth in this document.
11. This document shall not be reprinted, reproduced or duplicated in any form, in whole or in part, without prior written consent of Renesas Electronics.
12. Please contact a Renesas Electronics sales office if you have any questions regarding the information contained in this document or Renesas Electronics products.
(Note 1) "Renesas Electronics" as used in this document means Renesas Electronics Corporation and also includes its directly or indirectly controlled subsidiaries.
(Note 2) "Renesas Electronics product(s)" means any product developed or manufactured by or for Renesas Electronics.

(Rev.4.0-1 November 2017)



SALES OFFICES

Renesas Electronics Corporation

<http://www.renesas.com>

Refer to "<http://www.renesas.com/>" for the latest and detailed information.

Renesas Electronics America Inc.
1001 Murphy Ranch Road, Milpitas, CA 95035, U.S.A.
Tel: +1-408-432-8888, Fax: +1-408-434-5351

Renesas Electronics Canada Limited
9251 Yonge Street, Suite 8309 Richmond Hill, Ontario Canada L4C 9T3
Tel: +1-905-237-2004

Renesas Electronics Europe Limited
Dukes Meadow, Millboard Road, Bourne End, Buckinghamshire, SL8 5FH, U.K
Tel: +44-1628-651-700, Fax: +44-1628-651-804

Renesas Electronics Europe GmbH
Arcadiastrasse 10, 40472 Düsseldorf, Germany
Tel: +49-211-6503-0, Fax: +49-211-6503-1327

Renesas Electronics (China) Co., Ltd.
Room 1709 Quantum Plaza, No.27 ZhichunLu, Haidian District, Beijing, 100191 P. R. China
Tel: +86-10-8235-1155, Fax: +86-10-8235-7679

Renesas Electronics (Shanghai) Co., Ltd.
Unit 301, Tower A, Central Towers, 555 Langao Road, Putuo District, Shanghai, 200333 P. R. China
Tel: +86-21-2226-0888, Fax: +86-21-2226-0999

Renesas Electronics Hong Kong Limited
Unit 1601-1611, 16/F., Tower 2, Grand Century Place, 193 Prince Edward Road West, Mongkok, Kowloon, Hong Kong
Tel: +852-2265-6688, Fax: +852-2886-9022

Renesas Electronics Taiwan Co., Ltd.
13F, No. 363, Fu Shing North Road, Taipei 10543, Taiwan
Tel: +886-2-8175-9600, Fax: +886-2-8175-9670

Renesas Electronics Singapore Pte. Ltd.
80 Bendemeer Road, Unit #06-02 Hyflux Innovation Centre, Singapore 339949
Tel: +65-6213-0200, Fax: +65-6213-0300

Renesas Electronics Malaysia Sdn.Bhd.
Unit 1207, Block B, Menara Amcorp, Amcorp Trade Centre, No. 18, Jln Persiaran Barat, 46050 Petaling Jaya, Selangor Darul Ehsan, Malaysia
Tel: +60-3-7955-9390, Fax: +60-3-7955-9510

Renesas Electronics India Pvt. Ltd.
No.777C, 100 Feet Road, HAL 2nd Stage, Indiranagar, Bangalore 560 038, India
Tel: +91-80-67208700, Fax: +91-80-67208777

Renesas Electronics Korea Co., Ltd.
17F, KAMCO Yangjae Tower, 262, Gangnam-daero, Gangnam-gu, Seoul, 06265 Korea
Tel: +82-2-558-3737, Fax: +82-2-558-5338