

- 1 TRUE POSITION TOLERANCE OF THE POST TIPS APPLIES WHEN THE HEADERS ARE HELD FLAT AGAINST THE PRINTED CIRCUIT BOARD.
- 2 THE NOTED DIMENSIONS APPLY AT THE INTERSECTION OF THE POST AND THE HOUSING.
- 3 POINT OF MEASUREMENT FOR PLATING THICKNESS.
- 4 0.00076[.000030] GOLD IN CONTACT AREA, 0.00254-0.00504[.000100-.000200] MATTE TIN-LEAD ON SOLDER TAIL, ALL OVER 0.00127[.000050] NICKEL.
- 5 RETENTION FEATURES ON SOLDER TAILS, LOCATED AT MANUFACTURERS OPTION.
- 6 $\varnothing .020$ FOR KINKED TAILS
- 7 0.00076[.000030] GOLD IN CONTACT AREA, 0.00254-0.00504[.000100-.000200] MATTE TIN ON SOLDER TAIL, ALL OVER 0.00127[.000050] NICKEL.
- 8 HIGH TEMPERATURE CONFIGURATION

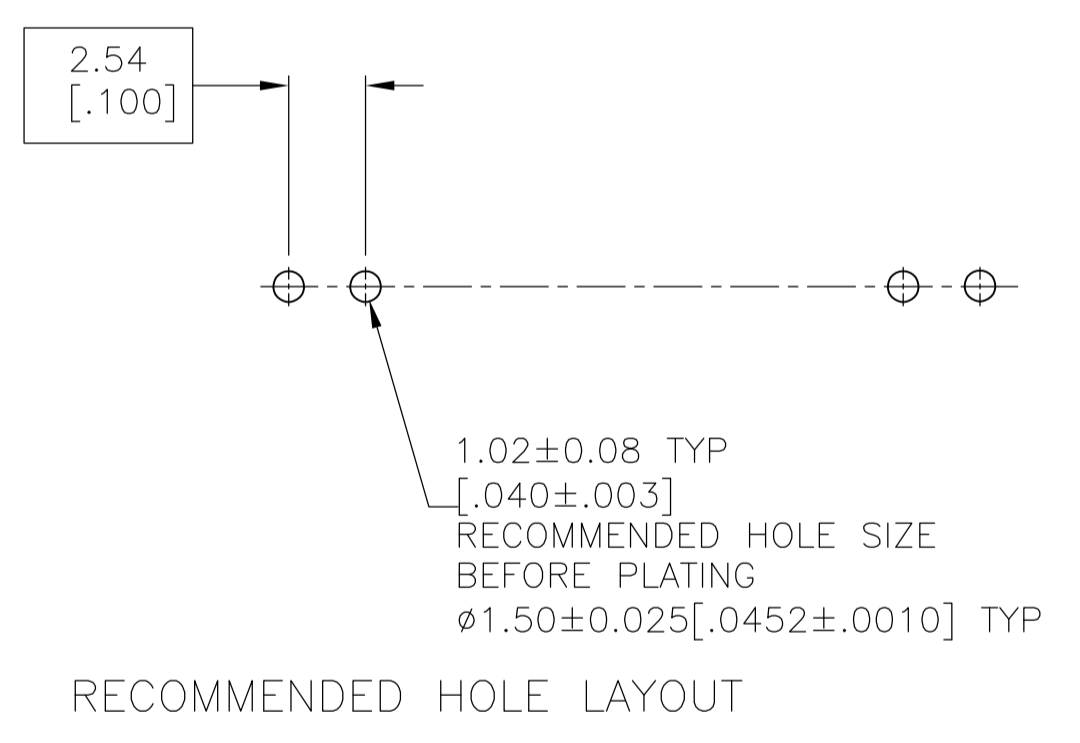

	8	7	2	3	9.75 [.384]	3	4	5-104608-4
OBSOLETE	8	7	4,8	9	27.53 [1.084]	10	11	5-104608-3
OBSOLETE		4	4	6	17.37 [.684]	6	7	104608-5
OBSOLETE		4	2	3	9.75 [.384]	3	4	104608-4
OBSOLETE		4	4,8	9	27.53 [1.084]	10	11	104608-3
OBSOLETE		4	3,5,8,10	9	32.61 [1.284]	12	13	104608-2
OBSOLETE		4	3,4,7,9,12,14	11	42.77 [1.684]	16	17	104608-1
REMARKS	PLATING	POST NO OMITTED	NO OF ACTIVE POSN	B	A	NO OF POSN	ASSEMBLY PART NUMBER	

THIS DRAWING IS A CONTROLLED DOCUMENT.

DIMENSIONS: mm [INCHES]	TOLERANCES UNLESS OTHERWISE SPECIFIED:	DIN J. GALLUCCI 7-7-89	TE Connectivity
0 PLC ± -	1 PLC ± -	C/K KATE HELM 12-7-89	
2 PLC ± -	3 PLC ± 0.13[.005]	APVD BILL SPINK 13-7-89	NAME
4 PLC ± -	ANGLES ± -	PRODUCT SPEC	HDR ASSY, BREAKAWAY, MOD II, WITH RETENTION FEATURE
MATERIAL: HOUSING: FLAME RETARDANT THERMOPLASTIC COLOR: BLACK POSTS: COPPER ALLOY	FINISH: SEE TABLE	WEIGHT: -	SIZE: A1
		CUSTOMER DRAWING	SCALE: 4:1 SHEET 1 OF 1 REV R