

P	LTR	DESCRIPTION	DATE	DWN	APVD
F		REV REDRAW PER ECN-23-193645	03APR2023	JAB	RL

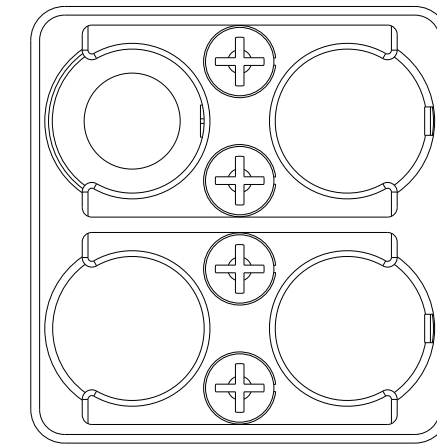
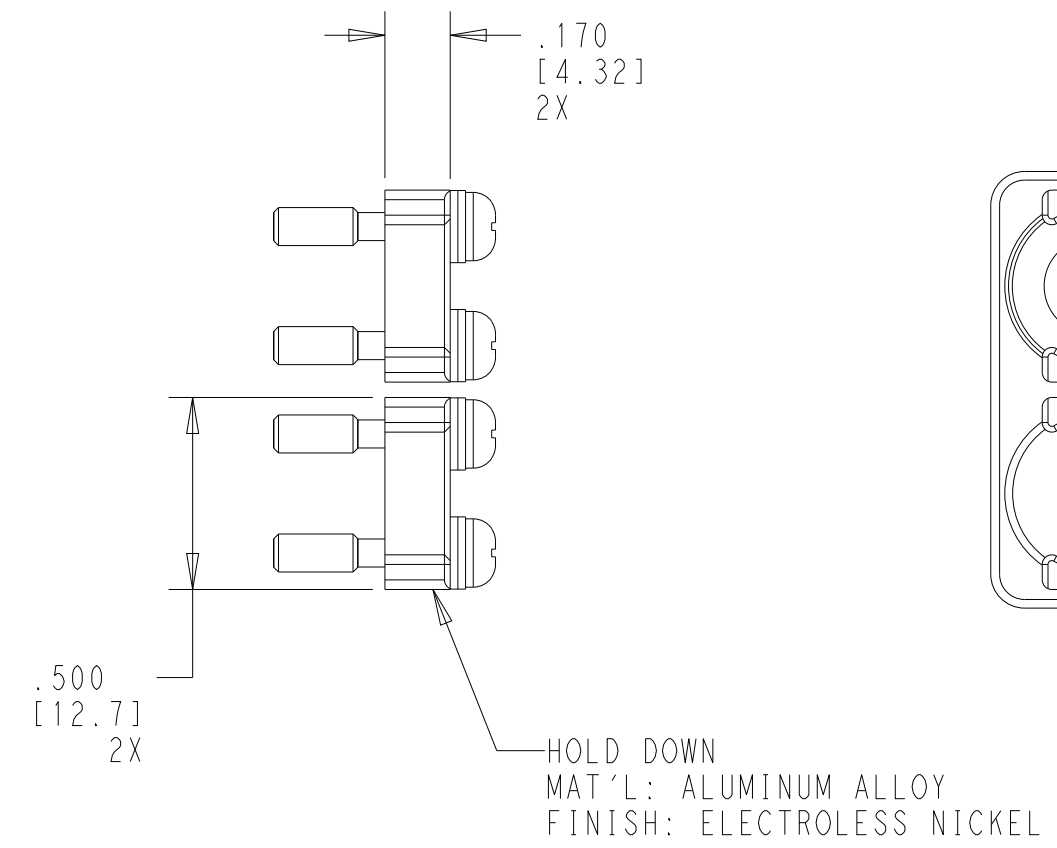
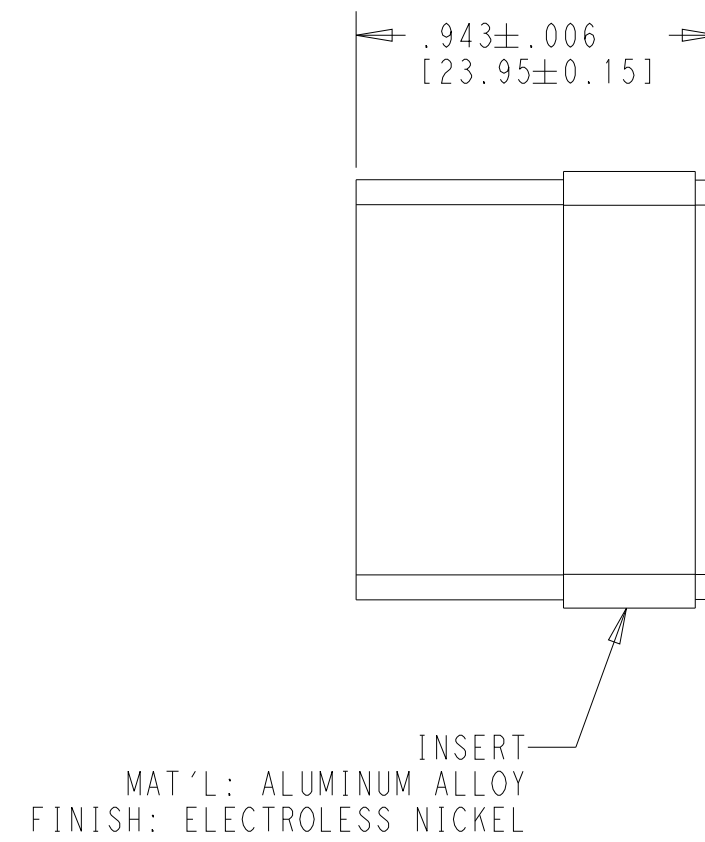
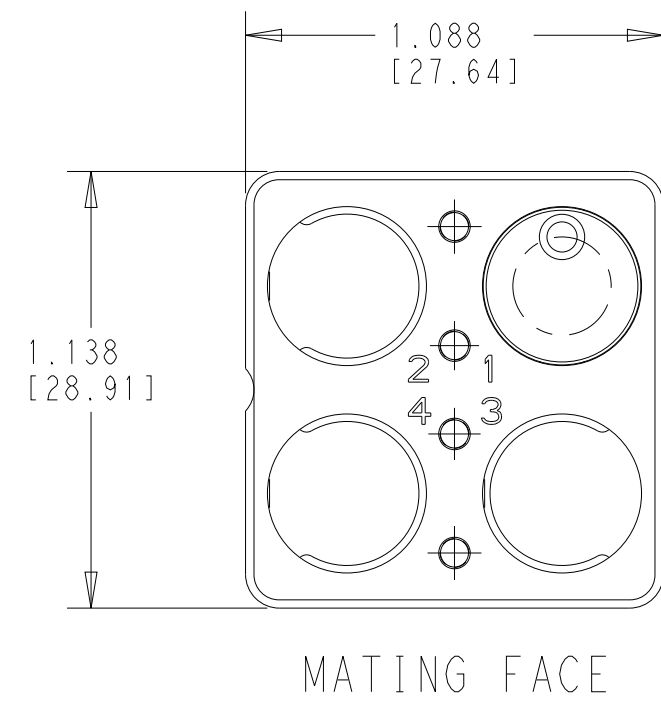
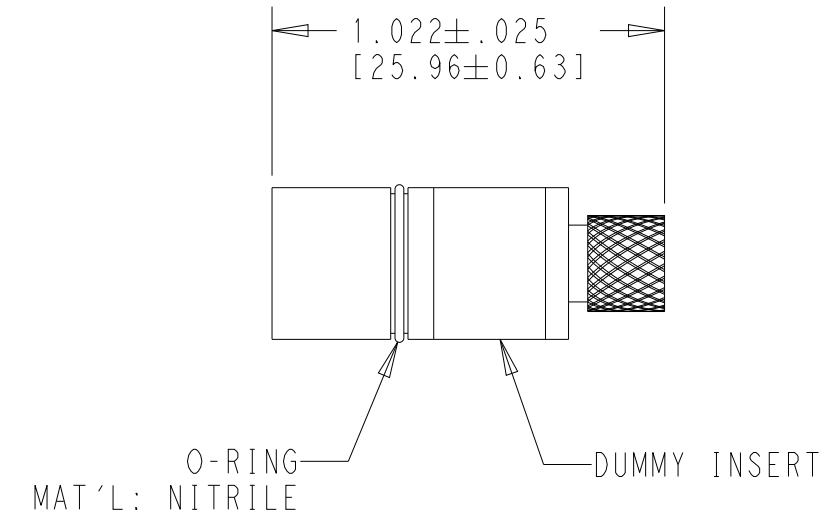

- 1 FOR 1484661-1 ONE DUMMY INSERT AND O-RING SUPPLIED TO PLUG UNUSED CAVITY. INSTALLATION AND LOCATION DETERMINED BY CUSTOMER.
- 2 FOR 1484661-3 FOUR DUMMY INSERTS AND O-RINGS SUPPLIED TO PLUG UNUSED CAVITIES. INSTALLATION TO BE DONE BY CUSTOMER.
- 3 CUSTOMER TO LUBRICATE O-RING WITH LUBRICANT COMPATIBLE WITH NITRILE RUBBER (RECOMMEND DOW CORNING 55 O-RING LUBRICANT)
- 4 OBSOLETE.
- 5 PRELIMINARY - NOT RELEASED FOR PRODUCTION.

2	5	1484661-4
2		1484661-3
1	4	1484661-2
1		1484661-1
REMARKS		PART NUMBER

DIMENSIONS:		TOLERANCES UNLESS OTHERWISE SPECIFIED:		DWN		CHK		APVD		NAME	
in		0 PLC	±	J. A. BAKER	31MAR2023	R. LACUESTA	03APR2023	R. LACUESTA	R. LACUESTA	INSERT KIT, PLUG, 4 POSN, MINI EB, ARINC 600	
		1 PLC	±								
		2 PLC	±								
		3 PLC	±.005 [0.13]								
		4 PLC	±								
		ANGLES	±								
		FINISH									
MATERIAL				PRODUCT SPEC		APPLICATION SPEC		WEIGHT		RESTRICTED TO	
				INTERFACE DRAWING		SCALE 2:1		SHEET 1 OF 1		REV F	