



NXP SMPS controller IC TEA1522 demonstration board

Cut costs and size for efficient low-power supplies

Discover how you can reduce costs, improve efficiency and shrink footprint for your low-power switched-mode power supply (SMPS) with our STARplug TEA1522 demonstration board. Designed for applications requiring universal mains input and 5 V output, it is particularly useful for USB charger applications. Numerous energy-saving and protection features enable efficient, robust and attractive slim-line power plugs.

TEA1522 key features

- ▶ Optimized for SMPS flyback operation
- ▶ Integrated 650 V MOSFET power switch
- ▶ Operates directly from rectified mains supply (80 to 276 V AC)
- ▶ Valley switching
- ▶ High voltage start-up
- ▶ Frequency reduction at low output power
- ▶ Switching can be stopped (0% duty cycle)
- ▶ Numerous built-in protections for robust design

Key benefits

- ▶ High efficiency
- ▶ Low standby power (< 100 mW)
- ▶ Low EMI
- ▶ Cost efficient
- ▶ Small footprint

Key applications

- ▶ USB charger
- ▶ Small power supplies
- ▶ White goods
- ▶ Small personal care equipment
- ▶ Chargers for portable equipment
- ▶ Coffee machines
- ▶ Security camera
- ▶ General domestic appliances

Our STARplug TEA1522 demo board is the perfect starting-point for creating compact, low-cost and highly efficient power supplies. Addressing applications that require universal mains input and 5 V output, the board is designed for outputs up to 1.2 A. It features secondary-side regulation with an opto coupler to ensure an extremely stable output.

For further space savings, it includes an integrated high-voltage power switch, start-up circuit and numerous protection features. These include cycle by cycle adjustable over current protection and under voltage lock-out along with over voltage, over temperature, short winding and demagnetization protection.

At the heart of the board is our low-power SMPS controller TEA1522, which operates directly from rectified universal mains. This IC is manufactured using a combination of our high-voltage EZ-HV and low-voltage BiCMOS processes, enabling a highly compact and cost-effective solution. In addition, 'green' features such as valley switching and frequency reduction ensure maximum efficiency in any operating conditions.

SMPS controller ICs for low-power systems

Type number	Package	R _{DS(on)} (Ω)	Max. output power	Application example
TEA1520T/N2	SO-14	48	2 – 5 W	Mobile adapter/standby supply
TEA1520P/N2	DIP-8	48	2 – 5 W	Mobile adapter/standby supply
TEA1521T/N2	SO-14	24	3 – 7 W	Mobile adapter/standby supply
TEA1521P/N2	DIP-8	24	3 – 7 W	Mobile adapter/standby supply
TEA1522T/N2	SO-14	12	7 – 9 W	Mobile adapter/standby supply
TEA1522P/N2	DIP-8	12	7 – 9 W	VCD
TEA1523P/N2	DIP-8	6.5	9 – 12 W	DVD
TEA1620P/N1	DIP-8	48	2 – 5 W	Standby supply
TEA1622P/N1	DIP-8	12	7 – 9 W	VCD
TEA1623P/N1	DIP-8	6.5	9 – 12 W	DVD
TEA1623PH/N1	HDIP-16	6.5	9 – 25 W	DVD-R/RW

Circuit diagram

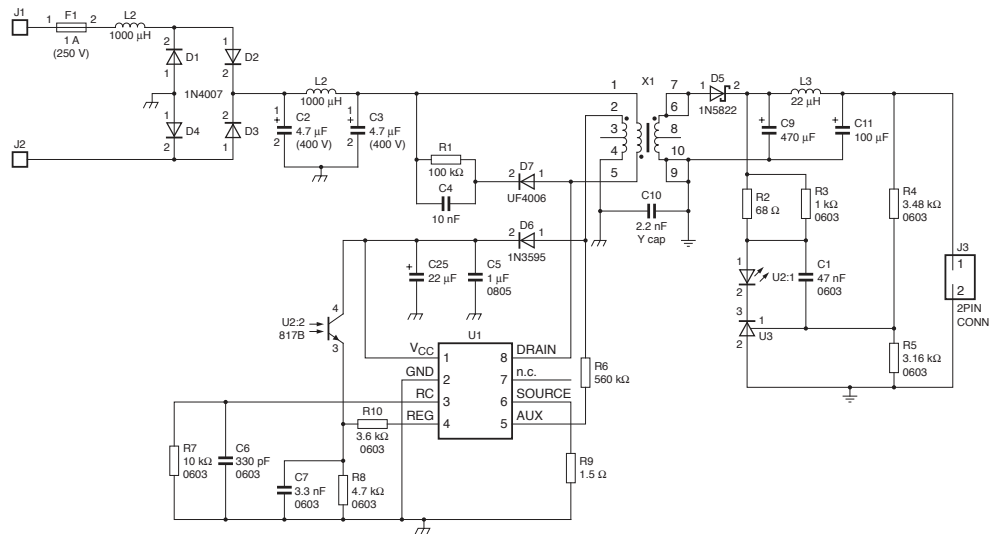

www.nxp.com



© 2007 NXP B.V.

All rights reserved. Reproduction in whole or in part is prohibited without the prior written consent of the copyright owner. The information presented in this document does not form part of any quotation or contract, is believed to be accurate and reliable and may be changed without notice. No liability will be accepted by the publisher for any consequence of its use. Publication thereof does not convey nor imply any license under patent- or other industrial or intellectual property rights.

Date of release: September 2007

Document order number: 9397 750 16160

Printed in the Netherlands