

FEATURES

HIGHLIGHTS

- Jitter generation <0.3 ps RMS (10 kHz to 20 MHz), meets jitter requirements of leading PHYs supporting 10GBASE-R, 10GBASE-W, 40GBASE-R, OC-192 and STM-64
- Supports ITU-T G.8261/G.8262 Synchronous Ethernet (SyncE) compliant equipment
- Supports clock generation for IEEE-1588 applications
- Generates SyncE interface clocks (1GE, 10GE, and 40GE)

MAIN FEATURES

- Provides an integrated solution for reference switching, frequency translation and jitter attenuation for SyncE and SONET/SDH interfaces
- Integrates 2 DPLLs, one for the transmit path and one for the receive path
- Selectable DPLL bandwidth: 18 Hz and 35 Hz
- Integrates 2 jitter attenuating APLLs to generate ultra-low jitter clocks
 - Supports 3 clock modes: SONET, Ethernet, and Ethernet LAN-PHY
 - Supports up to two crystal connections, allowing each APLL to support up to two modes of operation
- Supports input and output clocks covering a wide range of frequencies
 - Provides IN3, IN4, IN7, IN6 input CMOS clocks whose frequencies range from 2 kHz to 156.25 MHz
 - Provides IN1 and IN2 input differential clocks whose frequencies range from 2 kHz to 625 MHz
 - Provides OUT1 to OUT5 output CMOS clocks whose frequency range from 1PPS to 125 MHz
 - Provides OUT6~OUT9 output differential clocks whose frequency range from 25 MHz to 644.53125 MHz
- Provides a 1PPS, 2 kHz, 4 kHz, or 8 kHz frame sync input signal, and a 1PPS, 2 kHz or 8 kHz frame sync output signal
- Supports Forced or Automatic operating mode switch controlled by an internal state machine. Automatic mode switch supports Free-Run, Locked and Holdover modes
- Supports manual and automatic selected input clock switch
- Supports automatic hitless selected input clock switch on clock failure
- Supports three types of input clock sources: recovered clock from STM-N or OC-n, PDH network synchronization timing and external synchronization reference timing
- Supports LVPECL/LVDS and CMOS input/output technologies
- Supports master clock calibration
- Supports Telcordia GR-1244-CORE, Telcordia GR-253-CORE, ITU-T G.812, ITU-T G.8262, ITU-T G.813 and ITU-T G.783 Recommendations

OTHER FEATURES

- I2C Microprocessor interface
- IEEE 1149.1 JTAG Boundary Scan
- Single 3.3 V operation with 5 V tolerant CMOS I/Os
- 1mm ball pitch CABGA green package

APPLICATIONS

- Core and access IP switches / routers
- Gigabit and Terabit IP switches / routers
- Central Office Timing Source and Distribution
- DWDM cross-connect and transmission equipment
- IP core routers and access equipment
- Cellular and WLL base-station node clocks
- Broadband and multi-service access equipment

DESCRIPTION

The 82V3911 Synchronous Ethernet (SyncE) Two-channel PLL is a jitter attenuating device with rate conversion and reference switching capabilities; its ultra-low jitter output clocks are used to directly synchronize 10GBASE-R/10GBASE-W and OC-192/STM-64 PHYs and 40GBASE-R PHYs in Synchronous Ethernet and SONET/SDH equipment. When the 82V3911 is locked to a Synchronous Equipment Timing Source (SETS) that meets the requirements of ITU-T G.8262, G.813 or Telcordia GR-253-CORE Stratum 3 or SONET Minimum Clock the clocks generated by the 82V3911 will also meet those requirements.

The two 82V3911 timing channels are defined by independent Digital PLLs (DPLLs) with embedded clock synthesizers. The two independent timing channels allow the 82V3911 to synchronize transmit interfaces with the selected system backplane clock, and to simultaneously provide a recovered clock from a selected receive interface to the system backplane. DPLL1 is preferred for synchronizing transmit interfaces because it has the more sophisticated holdover mode.

Both DPLLs support three primary operating modes: Free-Run, Locked and Holdover. In Free-Run mode the DPLLs generate clocks based on the master clock alone. In Locked mode the DPLLs filter reference clock jitter with one of the following selectable bandwidths: 18 Hz or 35 Hz. In Locked mode the long-term DPLL frequency accuracy is the same as the long term frequency accuracy of the selected input reference. In Holdover mode the DPLL uses frequency data acquired while in Locked mode to generate accurate frequencies when input references are not available.

The 82V3911 requires a 12.8 MHz master clock for its reference monitors and other digital circuitry. The frequency accuracy of the master clock determines the frequency accuracy of the DPLLs in Free-Run mode. The frequency stability of the master clock determines the frequency stability of the DPLLs in Free-Run mode and in Holdover mode.

The 82V3911 provides four single ended reference inputs and two differential reference inputs that can operate at common Ethernet, SONET/SDH and PDH frequencies and other frequencies. The references are continually monitored for loss of signal and for frequency offset per user programmed thresholds. All of the references are available to both DPLLs. The active reference for each DPLL is determined by forced selection or by automatic selection based on user programmed priorities and locking allowances and based on the reference monitors.

The 82V3911 can accept a clock reference and a phase locked external sync signal as a pair. DPLL1 can lock to the reference clock input and align its frame sync and multi-frame sync outputs with the paired external sync input. The device provides two external sync inputs that can be associated with any of the six reference inputs to create up to two pairs. The external sync signals can have a frequency of 1 Hz, 2 kHz or 8 kHz. This feature enables DPLL1 to phase align its frame sync and multi-frame sync outputs with an external sync input without the need use a low bandwidth setting to lock directly to an external sync input.

The clocks synthesized by the 82V3911 DPLLs can be passed through either of the two independent voltage controlled crystal oscillator (VCXO) based jitter attenuating analog PLLs (APLLs). Both APLLs drive two independent dividers that have differential outputs. The APLLs use external crystal resonators with resonant frequencies equal to the APLL base frequency divided by 25. Both APLLs can be provisioned with one or two selectable crystal resonators to support up to two base frequencies per APLL. The output clocks generated by the APLLs exhibit jitter below 0.30ps RMS over the integration range 10 kHz to 20 MHz for most output frequencies.

FUNCTIONAL BLOCK DIAGRAM

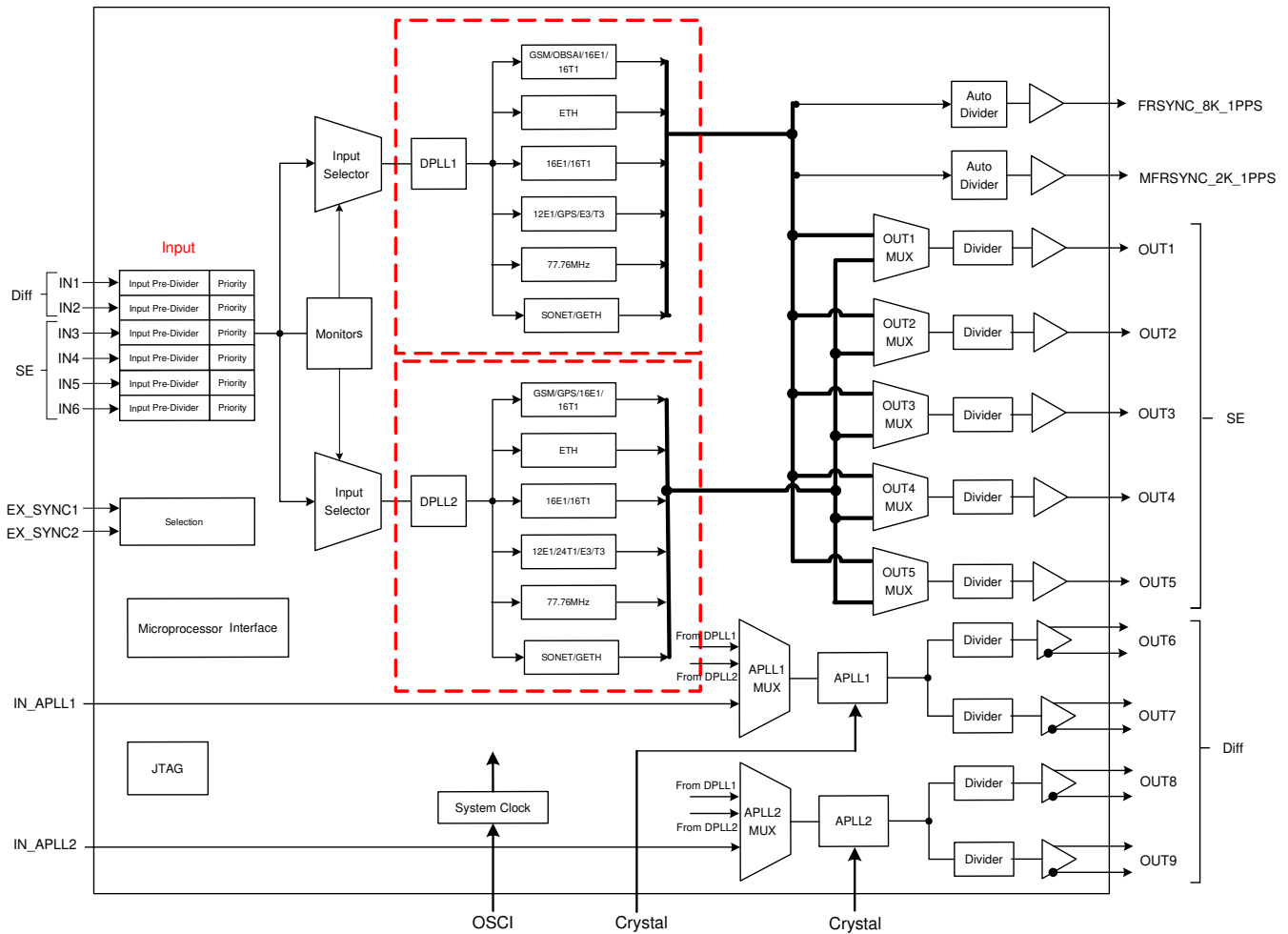

Figure 1. Functional Block Diagram

1 PIN ASSIGNMENT

	1	2	3	4	5	6	7	8	9	10	11	12	13	14	
A	IC10	VDDA	XTAL1_IN	CAP1	IN_APLL1_NEG	NC	NC	TDI	IC7	NC	OSCI	TMS	IC6	TRST	A
B	IC11	VSSA	XTAL1_OUT	VSSAO	IN_APLL1_POS	NC	NC	TDO/ DPLL1_ LOS_INT	VSSAO	TCK	VSSA	VSSA	VSSDO	VDDDO	B
C	IC4	VDDA	NC	CAP2	MFRSYNC_2 K_1PPS	FRSYNC_8K_ 1PPS	VDDDO	VSSDO	VDDA	VSSA	VDDA	VDDA	INT_REQ	NC	C
D	VSSA	VSSAO	CAP3	VSSA	VDDA	NC	VSSD	VDDD	IC2	VDDA	VSSA	VDDA	OUT4	OUT5	D
E	XTAL3_IN	XTAL3_OUT	VSSA	VSSAO	VSSA	SONET/SDH	VSSD	VDDD	IC1	VSSA	VDDA	VSSA	OUT2	OUT3	E
F	VDDD	VSSD	VSSAO	VSSA	VDDA	VSSAO	VSSD	VDDD	VSSD	VDDD	EX_SYNC1	VDDDO	OUT1	VSSDO	F
G	VSSD	VDDD	VSSAO	VSSAO	VSSAO	VSSD	VDDD	IC3	VDDD	VSSD	EX_SYNC2	NC	NC	NC	G
H	VDDAO	VSSAO	VDDAO	VSSAO	VSSAO	VSSAO	VSSD	VDDD	VSSD	VDDD	NC	NC	RST	IN3	H
J	OUT6_NEG	OUT6_POS	VDDAO	VSSAO	VDDAO	VSSAO	VDDAO	VSSAO	VSSA	VDDA	DPLL1_ LOCK	NC	IN4	IN5	J
K	VSSAO	VSSAO	VSSAO	VDDAO	VSSAO	VDDAO	VSSAO	VSSD	VDDD	VSSAO	DPLL2_ LOCK	IN6	I2C_SCL	I2C_SDA	K
L	OUT7_NEG	OUT7_POS	VDDAO	VSSAO	VSSAO	VSSAO	VSSAO	I2C_AD1	I2C_AD2	CAP4	VSSA	CAP5	VSSA	CAP6	L
M	VDDAO	VSSAO	VSSAO	VSSAO	VDDAO	VSSAO	VDDAO	VSSAO	VSSAO	VSSAO	VSSAO	NC	XTAL4_OUT	XTAL4_IN	M
N	VSSAO	OUT8_POS	VSSAO	OUT9_POS	VSSAO	IN_APLL2_ POS	IN1_POS	IN2_POS	VSSA	XTAL2_OUT	VSSA	IC9	VSSAO	VSSA	N
P	VDDAO	OUT8_NEG	VSSAO	OUT9_NEG	VDDAO	IN_APLL2_ NEG	IN1_NEG	IN2_NEG	VDDA	XTAL2_IN	VDDA	IC8	IC5	VDDA	P
	1	2	3	4	5	6	7	8	9	10	11	12	13	14	
Key:															
	Diff Outputs	Outputs	Inputs	Power	Ground										

Figure 2. Pin Assignment (Top View)

2 PIN DESCRIPTION

Table 1: Pin Description

Name	Pin No.	I/O	Type	Description ¹
Global Control Signal				
OSCI	A11	I	CMOS	OSCI: Crystal Oscillator Master Clock A nominal 12.8000 MHz clock provided by a crystal oscillator is input on this pin. It is the master clock for the device.
SONET/SDH	E6	I pull-down	CMOS	SONET/SDH: SONET / SDH Frequency Selection During reset, this pin determines the default value of the IN_SONET_SDH bit (b2, INPUT_MODE_CNFG): High: The default value of the IN_SONET_SDH bit is '1' (SONET); Low: The default value of the IN_SONET_SDH bit is '0' (SDH). After reset, the value on this pin takes no effect.
RST	H13	I pull-up	CMOS	RST: Reset A low pulse of at least 50 μ s on this pin resets the device. After this pin is high, the device will still be held in reset state for 500 ms (typical).
Frame Synchronization Input Signal				
EX_SYNC1	F11	I pull-down	CMOS	EX_SYNC1: External Sync Input 1 A 2 kHz, 4 kHz, 8 kHz, or 1PPS signal is input on this pin.
EX_SYNC2	G11	I pull-down	CMOS	EX_SYNC2: External Sync Input 1 A 2 kHz, 4 kHz, 8 kHz, or 1PPS signal is input on this pin.
Input Clock				
IN1_POS IN1_NEG	N7 P7	I	LVPECL/LVDS	IN1_POS / IN1_NEG: Positive / Negative Input Clock 1 A 2 kHz, 4 kHz, N x 8 kHz ³ , 1.544 MHz (SONET) / 2.048 MHz (SDH), 6.25 MHz, 6.48 MHz, 10MHz, 19.44 MHz, 25MHz, 25.92 MHz, 38.88 MHz, 51.84 MHz, 77.76 MHz, 125MHz, 155.52 MHz, 156.25 MHz, 311.04 MHz, 312.5 MHz, 622.08 MHz or 625 MHz clock is differentially input on this pair of pins. Whether the clock signal is LVPECL or LVDS is automatically detected. Single-ended input for differential input is also supported. Refer to Chapter 7.3.2.5 Single-Ended Input for Differential Input .
IN2_POS IN2_NEG	N8 P8	I	LVPECL/LVDS	IN2_POS / IN2_NEG: Positive / Negative Input Clock 2 A 2 kHz, 4 kHz, N x 8 kHz ³ , 1.544 MHz (SONET) / 2.048 MHz (SDH), 6.25 MHz, 6.48 MHz, 10MHz, 19.44 MHz, 25MHz, 25.92 MHz, 38.88 MHz, 51.84 MHz, 77.76 MHz, 125MHz, 155.52 MHz, 156.25 MHz, 311.04 MHz or 312.5 MHz, 622.08 MHz or 625 MHz clock is differentially input on this pair of pins. Whether the clock signal is LVPECL or LVDS is automatically detected. Single-ended input for differential input is also supported. Refer to Chapter 7.3.2.5 Single-Ended Input for Differential Input .
IN3	H14	I pull-down	CMOS	IN3: Input Clock 3 A 2 kHz, 4 kHz, N x 8 kHz ³ , 1.544 MHz (SONET) / 2.048 MHz (SDH), 6.25 MHz, 6.48 MHz, 10MHz, 19.44 MHz, 25MHz, 25.92 MHz, 38.88 MHz, 51.84 MHz, 77.76 MHz, 125MHz, 155.52 MHz or 156.25 MHz clock is input on this pin.
IN4	J13	I pull-down	CMOS	IN4: Input Clock 4 A 2 kHz, 4 kHz, N x 8 kHz ³ , 1.544 MHz (SONET) / 2.048 MHz (SDH), 6.25 MHz, 6.48 MHz, 10MHz, 19.44 MHz, 25MHz, 25.92 MHz, 38.88 MHz, 51.84 MHz, 77.76 MHz, 125MHz, 155.52 MHz or 156.25 MHz clock is input on this pin.
IN5	J14	I pull-down	CMOS	IN5: Input Clock 5 A 2 kHz, 4 kHz, N x 8 kHz ³ , 1.544 MHz (SONET) / 2.048 MHz (SDH), 6.25 MHz, 6.48 MHz, 10MHz, 19.44 MHz, 25MHz, 25.92 MHz, 38.88 MHz, 51.84 MHz, 77.76 MHz, 125MHz, 155.52 MHz or 156.25 MHz clock is input on this pin.

Table 1: Pin Description (Continued)

Name	Pin No.	I/O	Type	Description ¹
IN6	K12	I pull-down	CMOS	IN6: Input Clock 6 A 2 kHz, 4 kHz, N x 8 kHz ³ , 1.544 MHz (SONET) / 2.048 MHz (SDH), 6.25 MHz, 6.48 MHz, 10MHz, 19.44 MHz, 25MHz, 25.92 MHz, 38.88 MHz, 51.84 MHz, 77.76 MHz, 125MHz, 155.52 MHz or 156.25 MHz clock is input on this pin.
IN_APLL1_POS	B5	I pull-down	LVPECL/LVDS/ LVHSTL/SSTL/ HCSL	IN_APLL1_POS / IN_APLL1_NEG: Input Clock to APLL1 Direct input clock to APLL1. This pin is used for test. It can be left floating or a 1k Ω resistor can be tied from IN_APLL1_POS to ground.
IN_APLL1_NEG	A5	I pull-up/ pull-down		
IN_APLL2_POS	N6	I pull-down	LVPECL/LVDS/ LVHSTL/SSTL/ HCSL	IN_APLL2_POS / IN_APLL2_NEG: Input Clock APLL2 Direct input clock to APLL2. This pin is used for test. It can be left floating or a 1k Ω resistor can be tied from IN_APLL1_POS to ground.
IN_APLL2_NEG	P6	I pull-up/ pull-down		
Output Frame Synchronization Signal				
FRSYN- C_8K_1PPS	C6	O	CMOS	FRSYNC_8K_1PPS: 8 kHz Frame Sync Output An 8 kHz signal or a 1PPS Frame Pulse is output on this pin.
MFRSYN- C_2K_1PPS	C5	O	CMOS	MFRSYNC_2K_1PPS: 2 kHz Multiframe Sync Output A 2 kHz signal or a 1PPS Frame Pulse is output on this pin.
Output Clock				
OUT1 OUT2 OUT3 OUT4 OUT5	F13 E13 E14 D13 D14	O	CMOS	OUT1 ~ OUT5: Output Clock 1 ~ 5 A 1 pps, 400 Hz, 2 kHz, 8 kHz, 64 kHz, N x E1 ⁴ , N x T1 ⁵ , N x 13.0 MHz ⁶ , N x 3.84 MHz ⁷ , 5 MHz, 10 MHz, 20 MHz, E3, T3, 6.48 MHz, 19.44 MHz, 25.92 MHz, 38.88 MHz, 51.84 MHz, 77.76 MHz, 25MHz, or 125 MHz clock is output on these pins.
OUT6_POS OUT6_NEG	J2 J1	O	LVPECL/LVDS	OUT6_POS / OUT6_NEG: Positive / Negative Output Clock 6 A SONET based (77.76 MHz, 155.52 MHz, 311.04 MHz, 622.08 MHz), Ethernet based (25 MHz, 125 MHz, 156.25 MHz, 312.5 MHz, 625 MHz), or Ethernet LAN based (161.1328125 MHz, 322.265625 MHz, 644.53125 MHz) clock is differentially output on this pair of pins from APLL1.
OUT7_POS OUT7_NEG	L2 L1	O	LVPECL/LVDS	OUT7_POS / OUT7_NEG: Positive / Negative Output Clock 7 A SONET based (77.76 MHz, 155.52 MHz, 311.04 MHz, 622.08 MHz), Ethernet based (25 MHz, 125 MHz, 156.25 MHz, 312.5 MHz, 625 MHz), or Ethernet LAN based (161.1328125 MHz, 322.265625 MHz, 644.53125 MHz) clock is differentially output on this pair of pins from APLL1.
OUT8_POS OUT8_NEG	N2 P2	O	LVPECL/LVDS	OUT8_POS / OUT8_NEG: Positive / Negative Output Clock 8 A SONET based (77.76 MHz, 155.52 MHz, 311.04 MHz, 622.08 MHz), Ethernet based (25 MHz, 125 MHz, 156.25 MHz, 312.5 MHz, 625 MHz), or Ethernet LAN based (161.1328125 MHz, 322.265625 MHz, 644.53125 MHz) clock is differentially output on this pair of pins from APLL2.
OUT9_POS OUT9_NEG	N4 P4	O	LVPECL/LVDS	OUT9_POS / OUT9_NEG: Positive / Negative Output Clock 9 A SONET based (77.76 MHz, 155.52 MHz, 311.04 MHz, 622.08 MHz), Ethernet based (25 MHz, 125 MHz, 156.25 MHz, 312.5 MHz, 625 MHz), or Ethernet LAN based (161.1328125 MHz, 322.265625 MHz, 644.53125 MHz) clock is differentially output on this pair of pins from APLL2.
Miscellaneous				
CAP1, CAP2, CAP3	A4, C4, D3	O	Analog	CAP1, CAP2 and CAP3: Analog Power Filter Capacitor connection 1 to 3 Connect a 10uF capacitor in parallel with a low ESR 100nF capacitor between these pins and VSS1
CAP4, CAP5, CAP6	L10, L12, L14	O	Analog	CAP4, CAP5 and CAP6: Analog Power Filter Capacitor connection 4 to 6 Connect a 10uF capacitor in parallel with a low ESR 100nF capacitor between these pins and VSS2

Table 1: Pin Description (Continued)

Name	Pin No.	I/O	Type	Description ¹
XTAL1_IN	A3	I	Analog	Crystal oscillator 1 input. Determines first of two frequency families (Sonet/SDH, Ethernet or Ethernet*66/64) available for APLL1. Connect to ground if XTAL1 is not used.
XTAL1_OUT	B3	O	Analog	Crystal oscillator 1 output. Leave open if XTAL1 is not used.
XTAL2_IN	P10	I	Analog	Crystal oscillator 2 input. Determines first of two frequency families (chosen from Sonet/SDH, Ethernet or Ethernet*66/64) available for APLL2. Connect to ground if XTAL2 is not used
XTAL2_OUT	N10	O	Analog	Crystal oscillator 2 output. Leave open if XTAL2 is not used.
XTAL3_IN	E1	I	Analog	Crystal oscillator 3 input. Determines second of two frequency families (chosen from Sonet/SDH, Ethernet or Ethernet*66/64) available for APLL1. Connect to ground if XTAL3 is not used.
XTAL3_OUT	E2	O	Analog	Crystal oscillator 3 output. Leave open if XTAL3 is not used.
XTAL4_IN	M14	I	Analog	Crystal oscillator 4 input. Connect to ground if XTAL4 is not used. Determines second of two frequency families (chosen from Sonet/SDH, Ethernet or Ethernet*66/64) available for APLL2.
XTAL4_OUT	M13	O	Analog	Crystal oscillator 4 output. Leave open if XTAL4 is not used.
Lock Indication Signals				
DPLL2_LOCK	K11	O	CMOS	DPLL2 lock indicator. This pin goes high when DPLL2 is locked.
DPLL1_LOCK	J11	O	CMOS	DPLL1 lock indicator. This pin goes high when DPLL1 is locked.
Microprocessor Interface				
INT_REQ	C13	O	CMOS	INT_REQ: Interrupt Request This pin is used as an interrupt request. The output characteristics are determined by the HZ_EN bit (b1, INTERRUPT_CNFG) and the INT_POL bit (b0, INTERRUPT_CNFG).
I2C_SDA	K14	I/O pull-down	CMOS	I2C_SDA: Serial Data Input/Output This pin is used as the input/output for the I2C serial data.
I2C_AD1	L8	I pull-up	CMOS	I2C_AD1: Device Address Bit 1 I2C_AD2 and I2C_AD1 pins are the address bus of the microprocessor interface.
I2C_AD2	L9	I pull-up	CMOS	I2C_AD2: Device Address Bit 2 I2C_AD2 and I2C_AD1 pins are the address bus of the microprocessor interface.
I2C_SCL	K13	I pull-down	CMOS	I2C_SCL: Serial Clock Line The I2C serial clock is input on this pin.
JTAG (per IEEE 1149.1)				
TRST	A14	I pull-down	CMOS	TRST: JTAG Test Reset (Active Low) A low signal on this pin resets the JTAG test port. This pin should be connected to ground when JTAG is not used.
TMS	A12	I pull-up	CMOS	TMS: JTAG Test Mode Select The signal on this pin controls the JTAG test performance and is sampled on the rising edge of TCK.
TCK	B10	I pull-down	CMOS	TCK: JTAG Test Clock The clock for the JTAG test is input on this pin. TDI and TMS are sampled on the rising edge of TCK and TDO is updated on the falling edge of TCK. If TCK is idle at a low level, all stored-state devices contained in the test logic will indefinitely retain their state.
TDI	A8	I pull-up	CMOS	TDI: JTAG Test Data Input The test data is input on this pin. It is clocked into the device on the rising edge of TCK.

Table 1: Pin Description (Continued)

Name	Pin No.	I/O	Type	Description ¹
TDO/ DPLL1_LOS_INT	B8	O	CMOS	TDO: JTAG Test Data Output The test data is output on this pin. It is clocked out of the device on the falling edge of TCK. TDO pin outputs a high impedance signal except during the process of data scanning. DPLL1_LOS_INT: DPLL1 LOS Interrupt This pin can indicate the interrupt of DPLL1 selected input clock fail, as determined by the LOS_FLAG_ON_TDO bit (b6, MON_SW_HS_CNFG). Refer to Chapter 3.8.1 Input Clock Validity for details.
Power & Ground				
VDDD	D8, E8, F1, F8, F10, G2, G7, G9, H8, H10, K9	Power	-	Digital Core Power - +3.3V DC nominal
VDDDO	B14, C7, F12	Power	-	Digital Output Power - +3.3V DC nominal
VDDA	A2, C2, C9, C11, C12, D5, D10, D12, E11, F5, J10, P9, P11, P14	Power	-	Analog Core Power - +3.3V DC nominal
VDDAO	H1, H3, J3, J5, J7, K4, K6, L3, M1, M5, M7, P1, P5	Power	-	Analog Output Power - +3.3V DC nominal
VSSD	D7, E7, F2, F7, F9, G1, G6, G10, H7, H9, K8	Ground	-	Ground
VSSDO	B13, C8, F14	Ground	-	Ground
VSSA	B2, B11, B12, C10, D1, D4, D11, E3, E5, E10, E12, F4, J9, L11, L13, N9, N11, N14	Ground	-	Analog Ground
VSSAO	B4, B9, D2, E4, F3, F6, G3, G4, G5, H2, H4, H5, H6, J4, J6, J8, K1, K2, K3, K5, K7, K10, L4, L5, L6, L7, M2, M3, M4, M6, M8, M9, M10, M11, N1, N3, N5, N13, P3	Ground	-	Analog Output Ground

Table 1: Pin Description (Continued)

Name	Pin No.	I/O	Type	Description ¹
Others				
IC1	E9			IC: Internal Connected Internal Use. These pins should be left open for normal operation.
IC2	D9			
IC3	G8			
IC4	C1			
IC5	P13			
IC6	A13	-	-	
IC7	A9			
IC8	P12			
IC9	N12			
IC10	A1			
IC11	B1			
NC	A6, A7, A10, B6, B7, C3 C14, D6 G12, G13, G14, H11, H12, J12, M12	-	-	NC: Not Connected Not connected: There is no internal connection to these pins

Note:

1. All the unused input pins should be connected to ground; the output of all the unused output pins are don't-care.
2. The contents in the brackets indicate the position of the register bit/bits.
3. N x 8 kHz: $1 \leq N \leq 19440$.
4. N x E1: N = 1, 2, 3, 4, 6, 8, 12, 16
5. N x T1: N = 1, 2, 3, 4, 6, 8, 12, 16, 24
6. N x 13.0 MHz: N = 1, 2
7. N x 3.84 MHz: N = 1, 2, 4, 8

2.1 RECOMMENDATIONS FOR UNUSED INPUT AND OUTPUT PINS

2.1.1 INPUTS

Control Pins

All control pins have internal pull-ups or pull-downs; additional resistance is not required but can be added for additional protection. A 1k Ω resistor can be used.

Single-Ended Clock Inputs

For protection, unused single-ended clock inputs should be tied to ground.

Differential Clock Inputs

For applications not requiring the use of a differential input, both *_POS and *_NEG can be left floating. Though not required, but for additional protection, a 1k Ω resistor can be tied from _POS to ground.

XTAL Inputs

For applications not requiring the use of a crystal oscillator input, both _IN and _OUT can be left floating. Though not required, but for additional protection, a 1k Ω resistor can be tied from _IN to ground.

2.1.2 OUTPUTS

Status Pins

For applications not requiring the use of a status pin, we recommend bringing out to a test point for debugging purposes.

Single-Ended Clock Outputs

All unused single-ended clock outputs can be left floating, or can be brought out to a test point for debugging purposes.

Differential Clock Outputs

All unused differential outputs can be left floating. We recommend that there is no trace attached. Both sides of the differential output pair should either be left floating or terminated.

ORDERING INFORMATION

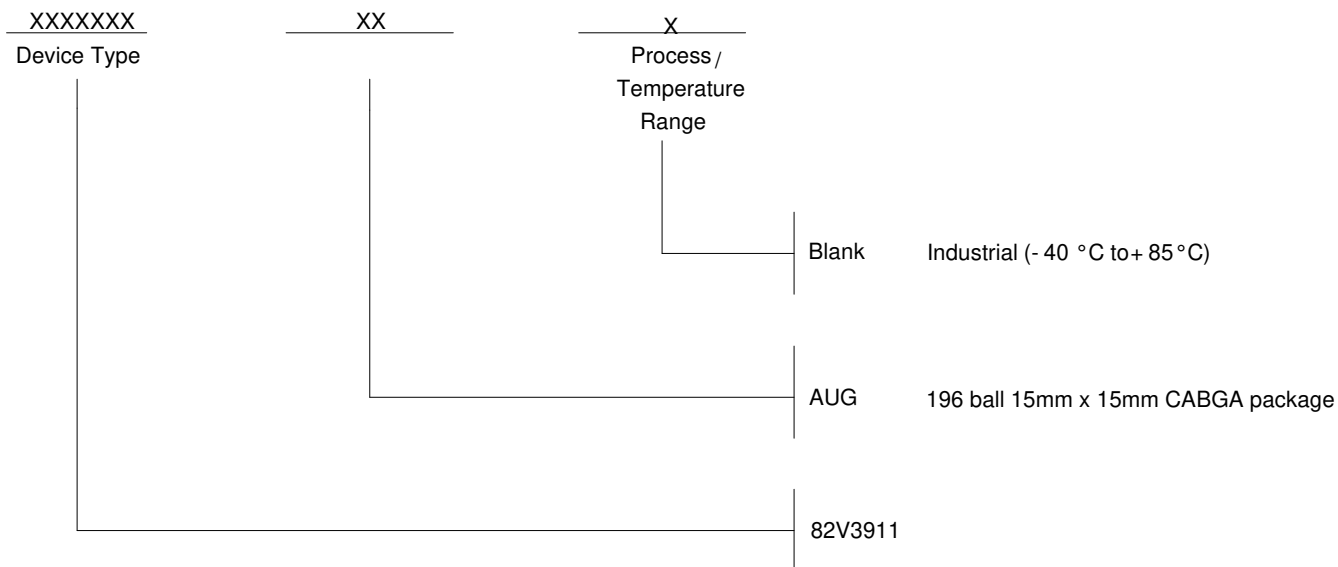

IMPORTANT NOTICE AND DISCLAIMER

RENESAS ELECTRONICS CORPORATION AND ITS SUBSIDIARIES (“RENESAS”) PROVIDES TECHNICAL SPECIFICATIONS AND RELIABILITY DATA (INCLUDING DATASHEETS), DESIGN RESOURCES (INCLUDING REFERENCE DESIGNS), APPLICATION OR OTHER DESIGN ADVICE, WEB TOOLS, SAFETY INFORMATION, AND OTHER RESOURCES “AS IS” AND WITH ALL FAULTS, AND DISCLAIMS ALL WARRANTIES, EXPRESS OR IMPLIED, INCLUDING, WITHOUT LIMITATION, ANY IMPLIED WARRANTIES OF MERCHANTABILITY, FITNESS FOR A PARTICULAR PURPOSE, OR NON-INFRINGEMENT OF THIRD PARTY INTELLECTUAL PROPERTY RIGHTS.

These resources are intended for developers skilled in the art designing with Renesas products. You are solely responsible for (1) selecting the appropriate products for your application, (2) designing, validating, and testing your application, and (3) ensuring your application meets applicable standards, and any other safety, security, or other requirements. These resources are subject to change without notice. Renesas grants you permission to use these resources only for development of an application that uses Renesas products. Other reproduction or use of these resources is strictly prohibited. No license is granted to any other Renesas intellectual property or to any third party intellectual property. Renesas disclaims responsibility for, and you will fully indemnify Renesas and its representatives against, any claims, damages, costs, losses, or liabilities arising out of your use of these resources. Renesas' products are provided only subject to Renesas' Terms and Conditions of Sale or other applicable terms agreed to in writing. No use of any Renesas resources expands or otherwise alters any applicable warranties or warranty disclaimers for these products.

(Disclaimer Rev.1.0 Mar 2020)

Corporate Headquarters

TOYOSU FORESIA, 3-2-24 Toyosu,
Koto-ku, Tokyo 135-0061, Japan
www.renesas.com

Contact Information

For further information on a product, technology, the most up-to-date version of a document, or your nearest sales office, please visit:
www.renesas.com/contact/

Trademarks

Renesas and the Renesas logo are trademarks of Renesas Electronics Corporation. All trademarks and registered trademarks are the property of their respective owners.