

THIS DRAWING IS UNPUBLISHED. RELEASED FOR PUBLICATION  
 © COPYRIGHT BY TYCO ELECTRONICS CORPORATION. ALL RIGHTS RESERVED.

LOC	DIST	REVISIONS			
P	LTR	DESCRIPTION	DATE	DWN	APVD
AD	00				
	A	REV PER EC 0512-0302-05	15DEC05	BC	GS
	A1	REVISED PER ECO-09-024927	10NOV09	KK	AEG
	B	ECR-10-019054	15SEP10	DP	MQW

- 1 POWER PIN BASE: BRASS.  
CONTACT SPRING: BERYLLIUM COPPER.  
RETENTION RING: BERYLLIUM COPPER.
- 2 GENERAL PLATING SPECIFICATION: UNDERPLATING  
(ENTIRE CONTACT): 1.27µm MIN NICKEL AND ACTION  
PIN: 0.5µm MIN TIN.  
FOR PLATING OF MATING SURFACES SEE APPLICABLE  
SPECIFICATION REFERENCE FOR EACH DASH NUMBER.
- 3 CONFORMS TO ALL TESTING ACCORDING TO IEC 61076-4-101  
PERFORMANCE LEVEL 2.
- 4 CONFORMS TO ALL TESTING ACCORDING TO IEC 61076-4-101  
PERFORMANCE LEVEL 1.
- 5. RECOMMENDED PLATED THROUGH HOLE DIMENSIONS: DRILLED HOLE IS  
ø3.19-3.25, COPPER THICKNESS 25µm MIN, TIN THICKNESS  
5µm MIN FOR A FINISHED HOLE SIZE OF ø3.02-3.20.
- 6 OBSOLETE PARTS: OBSOLETE CIS STREAMLINING PER D.RENAUD/D.SINISI

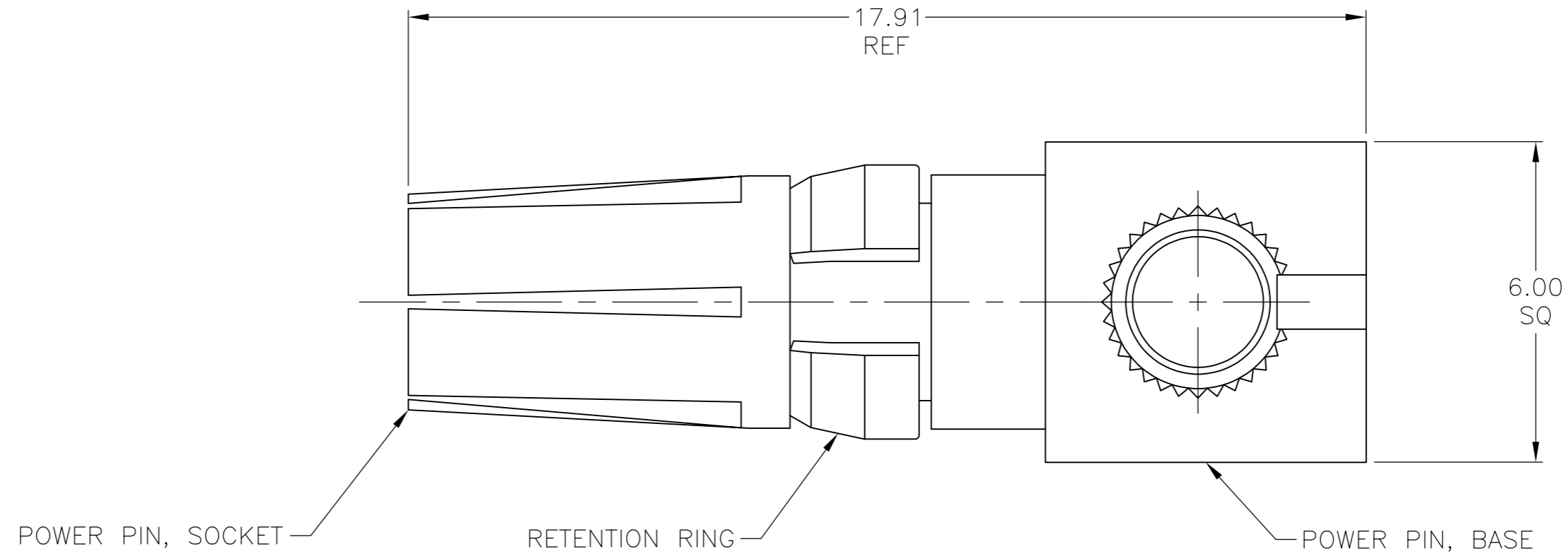
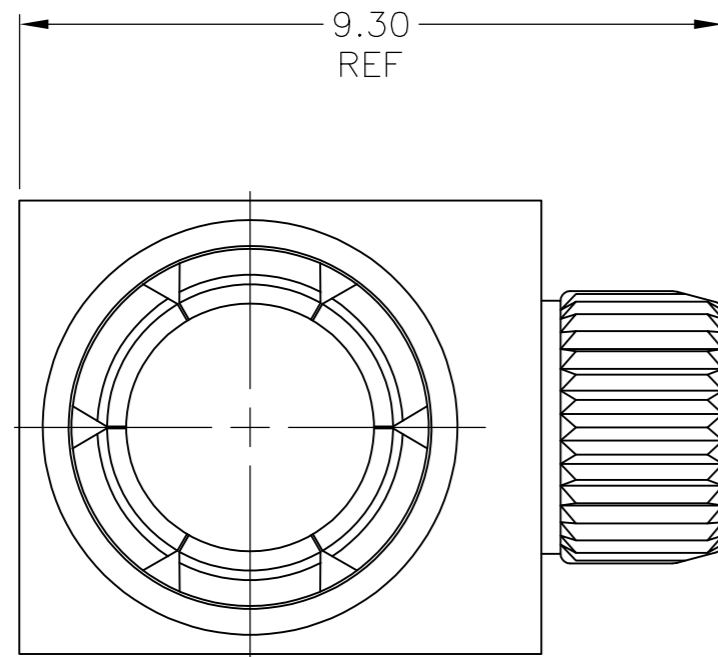

6	OBSOLETE	2 4	5646857-2
		2 3	5646857-1
	FINISH		PART NUMBER

THIS DRAWING IS A CONTROLLED DOCUMENT.		DWN B.CARBO 04AUG05	Tyco Electronics Corporation Harrisburg, PA 17105-3608	
DIMENSIONS: mm	TOLERANCES UNLESS OTHERWISE SPECIFIED:	CHK G.SKIPPER 04AUG05	NAME ASSEMBLY, POWER CONTACT, Z-PACK 2mm HM, TYPE M, FEMALE 90 DEG, PRINTED CIRCUIT BOARD MOUNT	
	0-PLG ± 1-PLG ± 2-PLG ± 0.13 ±0.2 3-PLG ± 4-PLG ± ANGLES ±	APVD G.SKIPPER 04AUG05	SIZE A2	CAGE CODE 00779
MATERIAL 1	FINISH SEE TABLE	PRODUCT SPEC APPLICATION SPEC	DRAWING NO C=5646857	RESTRICTED TO -
		WEIGHT -	SCALE 10:1	SHEET 1 of 1
		CUSTOMER DRAWING	REV B	

5646857