

- Designed for Complementary Use with the TIP2955 Series
- 90 W at 25°C Case Temperature
- 15 A Continuous Collector Current
- Customer-Specified Selections Available

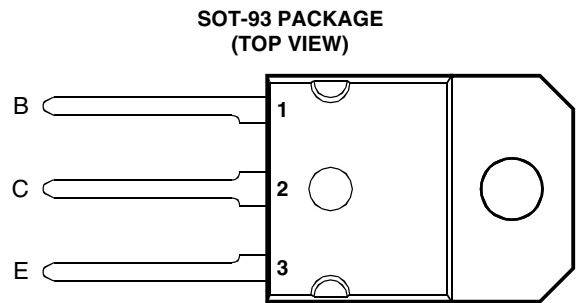

Pin 2 is in electrical contact with the mounting base.

MDTRAAA

absolute maximum ratings at 25°C case temperature (unless otherwise noted)

RATING	SYMBOL	VALUE	UNIT
Collector-base voltage ($I_E = 0$)	V_{CB0}	100	V
Collector-emitter voltage ($I_B = 0$) (see Note 1)	V_{CER}	70	V
Emitter-base voltage	V_{EBO}	7	V
Continuous collector current	I_C	15	A
Continuous base current	I_B	7	A
Continuous device dissipation at (or below) 25°C case temperature (see Note 2)	P_{tot}	90	W
Continuous device dissipation at (or below) 25°C free air temperature (see Note 3)	P_{tot}	3.5	W
Unclamped inductive load energy (see Note 4)	$\frac{1}{2}LI_C^2$	62.5	mJ
Operating junction temperature range	T_j	-65 to +150	°C
Storage temperature range	T_{stg}	-65 to +150	°C
Lead temperature 3.2 mm from case for 10 seconds	T_L	260	°C

- NOTES: 1. This value applies when the base-emitter resistance $R_{BE} = 100 \Omega$.
 2. Derate linearly to 150°C case temperature at the rate of 0.72 W/°C.
 3. Derate linearly to 150°C free air temperature at the rate of 28 mW/°C.
 4. This rating is based on the capability of the transistor to operate safely in a circuit of: $L = 20 \text{ mH}$, $I_{B(on)} = 0.4 \text{ A}$, $R_{BE} = 100 \Omega$, $V_{BE(off)} = 0$, $R_S = 0.1 \Omega$, $V_{CC} = 10 \text{ V}$.

PRODUCT INFORMATION

electrical characteristics at 25°C case temperature

PARAMETER	TEST CONDITIONS			MIN	TYP	MAX	UNIT
$V_{(BR)CEO}$ Collector-emitter breakdown voltage	$I_C = 30 \text{ mA}$	$I_B = 0$	(see Note 5)	60			V
I_{CER} Collector-emitter cut-off current	$V_{CE} = 70 \text{ V}$	$R_{BE} = 100 \Omega$				1	mA
I_{CEO} Collector cut-off current	$V_{CE} = 30 \text{ V}$	$I_B = 0$				0.7	mA
I_{CEV} Voltage between base and emitter	$V_{CE} = 100 \text{ V}$	$V_{BE} = -1.5 \text{ V}$				5	mA
I_{EBO} Emitter cut-off current	$V_{EB} = 7 \text{ V}$	$I_C = 0$				5	mA
h_{FE} Forward current transfer ratio	$V_{CE} = 4 \text{ V}$ $V_{CE} = 4 \text{ V}$	$I_C = 4 \text{ A}$ $I_C = 1.0 \text{ A}$	(see Notes 5 and 6)	20 5		70	
$V_{CE(sat)}$ Collector-emitter saturation voltage	$I_B = 0.4 \text{ A}$ $I_B = 3.3 \text{ A}$	$I_C = 4 \text{ A}$ $I_C = 1.0 \text{ A}$	(see Notes 5 and 6)			1.1 3	V
V_{BE} Base-emitter voltage	$V_{CE} = 4 \text{ V}$	$I_C = 4 \text{ A}$				1.8	V
h_{fe} Small signal forward current transfer ratio	$V_{CE} = 10 \text{ V}$	$I_C = 0.5 \text{ A}$	$f = 1 \text{ kHz}$	15			
$ h_{fe} $ Small signal forward current transfer ratio	$V_{CE} = 10 \text{ V}$	$I_C = 0.5 \text{ A}$	$f = 1 \text{ MHz}$	3			

NOTES: 5. These parameters must be measured using pulse techniques, $t_p = 300 \mu\text{s}$, duty cycle $\leq 2\%$.
6. These parameters must be measured using voltage-sensing contacts, separate from the current carrying contacts.

thermal characteristics

PARAMETER	MIN	TYP	MAX	UNIT
$R_{\theta JC}$ Junction to case thermal resistance			1.39	°C/W
$R_{\theta JA}$ Junction to free air thermal resistance			35.7	°C/W

resistive-load-switching characteristics at 25°C case temperature

PARAMETER	TEST CONDITIONS †			MIN	TYP	MAX	UNIT
t_{on} Turn-on time	$I_C = 6 \text{ A}$	$I_{B(on)} = 0.6 \text{ A}$	$I_{B(off)} = -0.6 \text{ A}$		0.6		μs
t_{off} Turn-off time	$V_{BE(off)} = -4 \text{ V}$	$R_L = 5 \Omega$	$t_p = 20 \mu\text{s}$, dc $\leq 2\%$		1		μs

† Voltage and current values shown are nominal; exact values vary slightly with transistor parameters.

TYPICAL CHARACTERISTICS

**TYPICAL DC CURRENT GAIN
vs
COLLECTOR CURRENT**

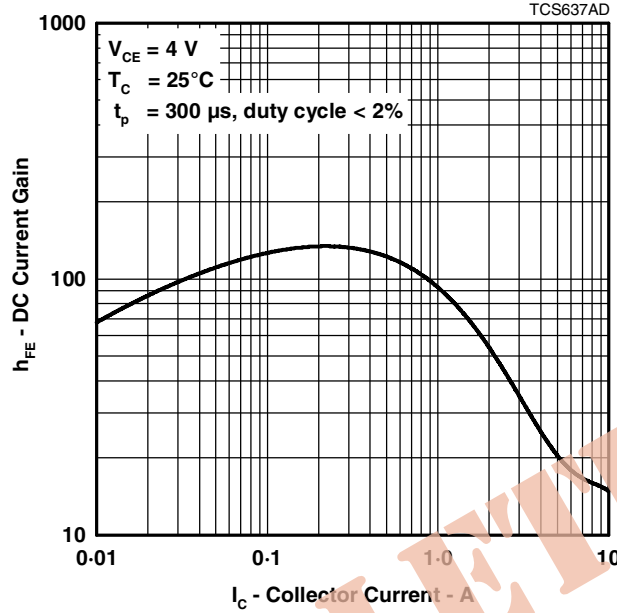

Figure 1.

MAXIMUM SAFE OPERATING REGIONS

**MAXIMUM FORWARD-BIAS
SAFE OPERATING AREA**

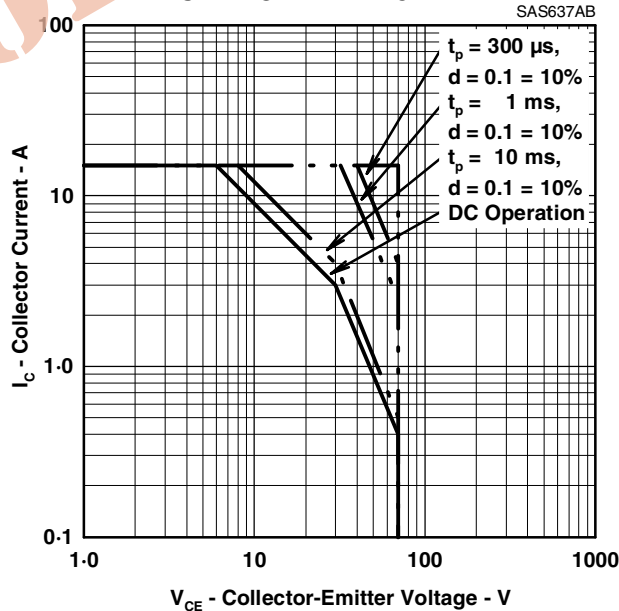

Figure 2.

PRODUCT INFORMATION

DECEMBER 1970 - REVISED SEPTEMBER 2002
Specifications are subject to change without notice.

THERMAL INFORMATION

**MAXIMUM POWER DISSIPATION
VS
CASE TEMPERATURE**

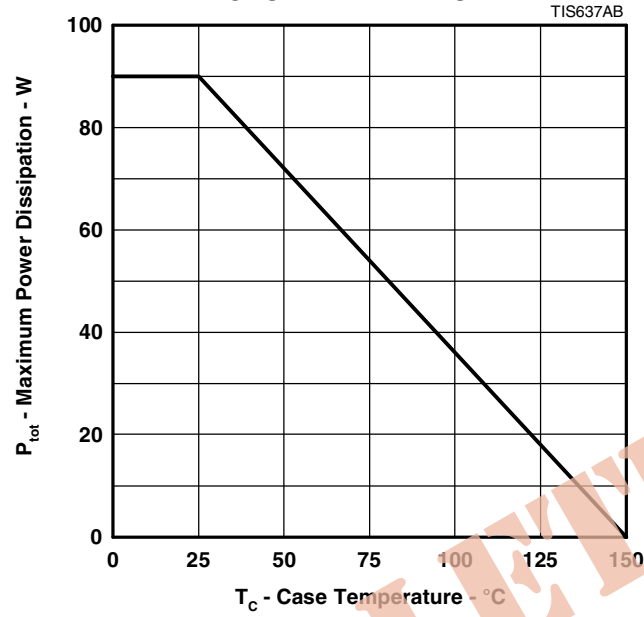

Figure 3.

OBSOLETE