



FSA3030 — High-Speed USB2.0/Mobile High-Definition Link (MHL™) with Negative Swing Audio

Features

- Low On Capacitance: 4.2 pF/5 pF MHL/USB (Typical)
- Low Power Consumption: 30 μ A Maximum
- Supports MHL Rev. 2.0
- MHL Data Rate: 4.0 Gbps
- Audio Swing: -1.5 V to +1.5 V (Typical)
- Packaged in 12-Lead UMLP (1.8 x 1.8 mm)
- Over-Voltage Tolerance (OVT) on all USB Ports Up to 5.25 V without External Components

Applications

- Cell Phones and Digital Cameras

Description

The FSA3030 is a bi-directional, low-power, high-speed, 3:1, USB2.0, MHL™ and audio switch. Configured as a double-pole, triple-throw (DP3T) switch, it is optimized for switching between high- or full-speed USB, Mobile High-Definition Link sources (per MHL Rev. 2.0 specification) and negative swing capable audio.

The FSA3030 contains special circuitry on the switch I/O pins, for applications where the V_{CC} supply is powered off ($V_{CC}=0$), that allows the device to withstand an over-voltage condition. This switch is designed to minimize current consumption even when the control voltage applied to the control pins is lower than the supply voltage (V_{CC}). This is especially valuable in mobile applications, such as cell phones, allowing direct interface with the general-purpose I/Os of the baseband processor. Other applications include switching and connector sharing in portable cell phones, digital cameras, and notebook computers.

Ordering Information

| Part Number | Top Mark | Operating Temperature Range | Package |
|-------------|----------|-----------------------------|--|
| FSA3030UMX | LU | -40 to +85°C | 12-Lead, Ultrathin Molded Leadless Package (UMLP), 1.8 mm x 1.8 mm |

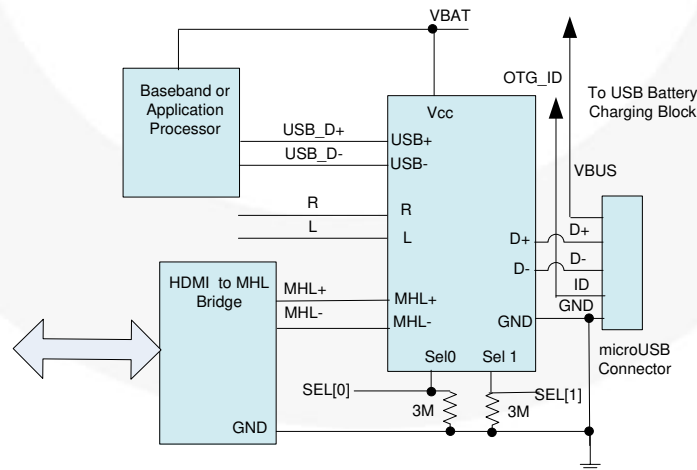

Figure 1. Typical Application

All trademarks are the property of their respective owners.

Analog Symbol

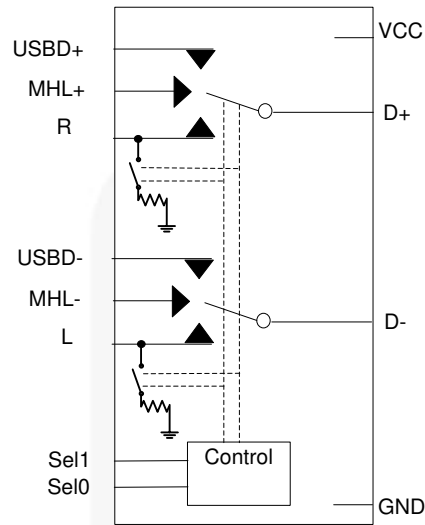

Figure 2. Analog Symbol

Table 1. Data Switch Select Truth Table

| SEL1 ⁽¹⁾ | SEL0 ⁽¹⁾ | Shunt | Function |
|---------------------|---------------------|---------|------------------------------|
| 0 | 0 | Enable | D+/D- connected to USB+/USB- |
| 0 | 1 | Disable | D+/D- connected to R/L |
| 1 | 0 | Enable | D+/D- connected to MHL+/MHL |
| 1 | 1 | Enable | D+/D- High Impedance |

Note:

- Control inputs should never be left floating or unconnected. To guarantee default switch closure to the USB position, the SEL[0:1] pins should be tied to GND with a weak pull-down resistor (3 MΩ) to minimize static current draw.

Pin Configuration

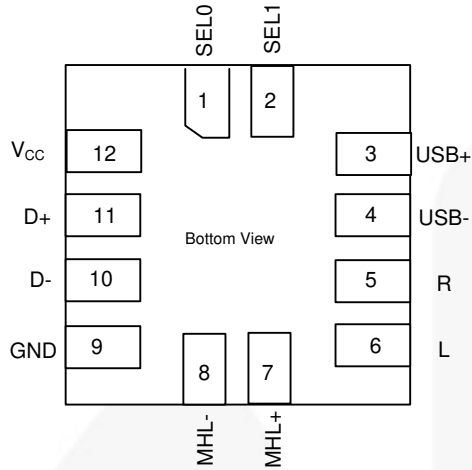

Figure 3. Pin Assignments

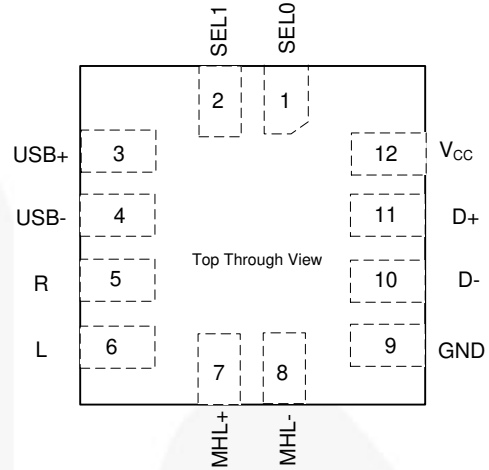

Figure 4. Top Through View

Pin Definitions

| Pin# | Name | Description |
|------|-----------------|----------------------------------|
| 1 | SEL0 | Data Switch Select |
| 2 | SEL1 | Data Switch Select |
| 3 | USB+ | USB Differential Data (Positive) |
| 4 | USB- | USB Differential Data (Negative) |
| 5 | R | Audio Right |
| 6 | L | Audio Left |
| 7 | MHL+ | MHL Differential Data (Positive) |
| 8 | MHL- | MHL Differential Data (Negative) |
| 9 | GND | Ground |
| 10 | D- | Data Switch Output (Positive) |
| 11 | D+ | Data Switch Output (Negative) |
| 12 | V _{CC} | Device Power from System |

Absolute Maximum Ratings

Stresses exceeding the absolute maximum ratings may damage the device. The device may not function or be operable above the recommended operating conditions and stressing the parts to these levels is not recommended. In addition, extended exposure to stresses above the recommended operating conditions may affect device reliability. The absolute maximum ratings are stress ratings only.

| Symbol | Parameter | Min. | Max. | Unit | |
|--------------------------------|---|----------|-----------------|-----------------|----|
| V _{CC} | Supply Voltage | -0.5 | 6.0 | V | |
| V _{CNTRL} | DC Input Voltage (SEL[1:0]) ⁽²⁾ | -0.5 | V _{CC} | V | |
| V _{SW} ⁽³⁾ | DC Switch I/O Voltage ⁽²⁾ | USB | -0.5 | V _{CC} | V |
| | | MHL | -0.5 | V _{CC} | |
| | | AUDIO | -2.0 | 3 | |
| I _{IK} | DC Input Diode Current | -50 | | mA | |
| I _{OUT} | Switch DC Output Current (Continuous) | USB | | 60 | mA |
| | | MHL | | 60 | mA |
| | | AUDIO | | 60 | mA |
| I _{OUTPEAK} | Switch DC Output Peak Current (Pulsed at 1 ms Duration, <10% Duty Cycle) | USB | | 150 | mA |
| | | MHL | | 150 | mA |
| | | AUDIO | | 150 | mA |
| T _{STG} | Storage Temperature | -65 | +150 | °C | |
| MSL | Moisture Sensitivity Level: JEDEC J-STD-020A | | 1 | | |
| ESD | IEC 61000-4-2, Level 4, for D+/D- and V _{CC} Pins ⁽⁴⁾ | Contact | | 15 | kV |
| | IEC 61000-4-2, Level 4, for D+/D- and V _{CC} Pins ⁽⁴⁾ | Air | | 8 | |
| | Human Body Model, JEDEC: JESD22-A114 | All Pins | | 3.5 | |
| | Charged Device Model, JESD22-C101 | | | 2 | |

Notes:

- The input and output negative ratings may be exceeded if the input and output diode current ratings are observed.
- V_{SW} refers to analog data switch paths (USB, MHL, and audio).
- Testing performed in a system environment using TVS diodes.

Recommended Operating Conditions

The Recommended Operating Conditions table defines the conditions for actual device operation. Recommended operating conditions are specified to ensure optimal performance to the datasheet specifications. Fairchild does not recommend exceeding them or designing to Absolute Maximum Ratings.

| Symbol | Parameter | Min. | Max. | Unit |
|------------------------|---|------|------|------|
| V _{CC} | Supply Voltage | 2.5 | 4.5 | V |
| t _{RAMP(VCC)} | Power Supply Slew Rate | 100 | 1000 | μs/V |
| θ _{JA} | Thermal Resistance | | 230 | °C/W |
| V _{CNTRL} | Control Input Voltage (SEL[1:0]) ⁽⁵⁾ | 0 | 4.5 | V |
| V _{SW(USB)} | Switch I/O Voltage (USB Switch Path) | -0.5 | 3.6 | V |
| V _{SW(MHL)} | Switch I/O Voltage (MHL Switch Path) | 1.65 | 3.45 | V |
| V _{SW(AUD)} | Switch I/O Voltage (Audio Switch Path) | -1.5 | 3.0 | V |
| T _A | Operating Temperature | -40 | +85 | °C |

Note:

- The control inputs must be held HIGH or LOW; they must not float.

DC Electrical Characteristics

All typical value are at $T_A=25^{\circ}\text{C}$ unless otherwise specified.

| Symbol | Parameter | Condition | V _{CC} (V) | T _A =- 40°C to +85°C | | | Unit |
|--------------------------|--|--|---------------------|---------------------------------|------|------------|------|
| | | | | Min. | Typ. | Max. | |
| V _{IK} | Clamp Diode Voltage | I _{IN} =-18 mA | 2.5 | | | -1.2 | V |
| V _{IH} | Control Input Voltage High SEL[1:0] | | 2.5 to 4.50 | 1.0 | | | V |
| V _{IL} | Control Input Voltage Low SEL[1:0] | | 2.5 to 4.50 | | | 0.5 | V |
| I _{IN} | Control Input Leakage SEL[1:0] | V _{SW} (USB/MHL)=0 to 3.6 V, V _{SW} (AUD)=0 to 3.0 V, V _{CNTRL} =0 to V _{CC} | 4.5 | -0.5 | | 0.5 | μA |
| I _{OZ(MHL)} | Off-State Leakage for Open MHL Data Paths | V _{SW} =1.65 ≤ MHL ≤ 3.45 V SEL[1:0]=V _{CC} | 4.5 | -1 | | 1 | μA |
| I _{OZ(USB)} | Off-State Leakage for Open USB Data Paths | V _{SW} =0 ≤ USB ≤ 3.6 V SEL[1:0]=V _{CC} | 4.5 | -0.5 | | 0.5 | μA |
| I _{CL(MHL)} | On-State Leakage for Closed MHL Data Paths ⁽⁶⁾ | V _{SW} =1.65 ≤ MHL ≤ 3.45 V, SEL0=GND, SEL1=V _{CC} , Other Side of Switch Float | 4.5 | -0.75 | | 0.75 | μA |
| I _{CL(USB)} | On-State Leakage for Closed USB Data Paths ⁽⁶⁾ | V _{SW} =0 ≤ USB ≤ 3.6 V SEL[1:0]=GND, Other Side of Switch Float | 4.5 | -0.75 | | 0.75 | μA |
| I _{CL(AUD)} | On-State Leakage for Closed ⁽⁶⁾ AUDIO Data Path | V _{SW} =-1.5 ≤ R/L ≤ 1.5 V SEL1=GND, SEL0=V _{CC} , Other Side of Switch Float | 4.5 | -1.0 | | 1.0 | μA |
| I _{OFF} | Power-Off Leakage Current (All I/O Ports) | V _{SW} (USB/MHL)=0 to 3.6 V, V _{SW} (AUD)=0 to 3.0 V, Figure 5 | 0 | -1 | | 1 | μA |
| R _{ON(USB)} | HS Switch On Resistance (USB to D Path) | V _{SW} =0.4 V, I _{ON} =-8 mA, SEL[1:0]=GND, Figure 6 | 2.5 | | | 4.5 | Ω |
| R _{ON(MHL)} | HS Switch On Resistance (MHL to D Path) | V _{SW} =V _{CC} -1050 mV, SEL0=GND, SEL1=V _{CC} I _{ON} =-8 mA, Figure 6 | 2.5 | | | 5 | Ω |
| R _{ON(Audio)} | Audio Switch On Resistance (R/L Path) | V _{SW} = -1.5 V to 1.5 V, SEL1=GND, SEL0=V _{CC} , I _{ON} =-24 mA, Figure 6 | 2.5 | | | 4 | Ω |
| ΔR _{ON(MHL)} | Difference in R _{ON} Between MHL Positive-Negative | V _{SW} =V _{CC} -1050 mV, SEL0=GND, SEL1=V _{CC} , I _{ON} =-8 mA, Figure 6, | 2.5 | | | 0.03 | Ω |
| ΔR _{ON(USB)} | Difference in R _{ON} Between USB Positive-Negative | V _{SW} =0.4 V, I _{ON} = -8 mA, SEL[1:0]=GND, Figure 6 | 2.5 | | | 0.18 | Ω |
| R _{ONF(MHL)} | Flatness for R _{ON} MHL Path | V _{SW} =1.65 to 3.45V, SEL0=GND, SEL1=V _{CC} , I _{ON} =-8 mA, Figure 6 | 2.5 | | | 1 | Ω |
| R _{ONFA(AUDIO)} | Flatness for R _{ON} Audio Path | V _{SW} =-1.5 V to 1.5 V, SEL1=GND, SEL0=V _{CC} , I _{ON} =-24 mA, Figure 6 | 2.5 | | | 0.1 | Ω |
| R _{SH} | Shunt Resistance | | 3.6 | | | 125 200 | Ω |
| I _{CC} | Quiescent Current | V _{CNTRL} =0 or 4.5 V, I _{OUT} =0 | 4.5 | | | 30 | μA |
| I _{CCCT} | Delta Increase in Quiescent Current per Control Pin | V _{CNTRL} =1.65 V, I _{OUT} =0 | 4.5 | | | 18 | μA |
| | | V _{CNTRL} =2.5 V, I _{OUT} =0 | 4.5 | | | 10 | |

Note:

6. For this test, the data switch is closed with the respective switch pin floating.

AC Electrical Characteristics

All typical values are for $V_{CC}=3.3$ V and $T_A=25^\circ\text{C}$ unless otherwise specified.

| Symbol | Parameter | Condition | V_{CC} (V) | $T_A=-40^\circ\text{C}$ to $+85^\circ\text{C}$ | | | Unit |
|----------------|--|--|--------------|--|------|------|------|
| | | | | Min. | Typ. | Max. | |
| t_{ONUSB} | USB Turn-On Time, SEL[1:0] to Output | $R_L=50\ \Omega$, $C_L=5\ \text{pF}$, $V_{SW(USB)}=0.8\ \text{V}$, $V_{SW(MHL)}=3.3\ \text{V}$, $V_{SW(AUD)}=1.5\ \text{V}$, Figure 7, Figure 8 | 2.5 to 3.6 | | 445 | 600 | ns |
| t_{OFFUSB} | USB Turn-Off Time, SEL[1:0] to Output | $R_L=50\ \Omega$, $C_L=5\ \text{pF}$, $V_{SW(USB)}=0.8\ \text{V}$, $V_{SW(MHL)}=3.3\ \text{V}$, $V_{SW(AUD)}=1.5\ \text{V}$, Figure 7, Figure 8 | 2.5 to 3.6 | | 445 | 600 | ns |
| t_{ONAUD} | AUDIO Turn-On Time, SEL[1:0] to Output | $R_L=50\ \Omega$, $C_L=5\ \text{pF}$, $V_{SW(USB)}=0.8\ \text{V}$, $V_{SW(MHL)}=3.3\ \text{V}$, $V_{SW(AUD)}=1.5\ \text{V}$, Figure 7, Figure 8 | 2.5 to 3.6 | | 445 | 600 | ns |
| t_{OFFAUD} | AUDIO Turn-Off Time, SEL[1:0] to Output | $R_L=50\ \Omega$, $C_L=5\ \text{pF}$, $V_{SW(USB)}=0.8\ \text{V}$, $V_{SW(MHL)}=3.3\ \text{V}$, $V_{SW(AUD)}=1.5\ \text{V}$, Figure 7, Figure 8 | 2.5 to 3.6 | | 445 | 600 | ns |
| t_{ONMHL} | MHL Turn-On Time, SEL[1:0] to Output | $R_L=50\ \Omega$, $C_L=5\ \text{pF}$, $V_{SW(USB)}=0.8\ \text{V}$, $V_{SW(MHL)}=3$, $V_{SW(AUD)}=1.5\ \text{V}$, Figure 7, Figure 8 | 2.5 to 3.6 | | 445 | 600 | ns |
| t_{OFFMHL} | MHL Turn-Off Time, SEL[1:0] to Output | $R_L=50\ \Omega$, $C_L=5\ \text{pF}$, $V_{SW(USB)}=0.8\ \text{V}$, $V_{SW(MHL)}=3.3\ \text{V}$, $V_{SW(AUD)}=1.5\ \text{V}$, Figure 7, Figure 8 | 2.5 to 3.6 | | 445 | 600 | ns |
| t_{PD} | Propagation Delay ⁽⁷⁾ | $C_L=5\ \text{pF}$, $R_L=50\ \Omega$, Figure 7, Figure 9 | 2.5 to 3.6 | | 0.25 | | ns |
| t_{BBM} | Break-Before-Make ⁽⁷⁾ | $R_L=50\ \Omega$, $C_L=5\ \text{pF}$, $V_{AUD}=1.5\ \text{V}$, $V_{MHL}=3.3\ \text{V}$, $V_{USB}=0.8\ \text{V}$, Figure 10 | 2.5 to 3.6 | | 350 | | ns |
| $O_{IRR(MHL)}$ | Off Isolation ⁽⁷⁾ | $V_S=1\ \text{V}_{pk-pk}$, $R_L=50\ \Omega$, $f=240\ \text{MHz}$, Figure 11 | 2.5 to 3.6 | | -33 | | dB |
| $O_{IRR(USB)}$ | | $V_S=400\ \text{mV}_{pk-pk}$, $R_L=50\ \Omega$, $f=240\ \text{MHz}$, Figure 11 | 2.5 to 3.6 | | -38 | | dB |
| $Xtalk_{MHL}$ | Non-Adjacent Channel ⁽⁷⁾ Crosstalk | $V_S=1\ \text{V}_{pk-pk}$, $R_L=50\ \Omega$, $f=240\ \text{MHz}$, Figure 12 | 2.5 to 3.6 | | -44 | | dB |
| $Xtalk_{USB}$ | | $V_S=400\ \text{mV}_{pk-pk}$, $R_L=50\ \Omega$, $f=240\ \text{MHz}$, Figure 12 | 2.5 to 3.6 | | -39 | | dB |
| $Xtalk_{AUD}$ | | $V_S=100\ \text{mV}_{RMS}$, $R_L=32\ \Omega$, $f=20\ \text{kHz}$, Figure 12 | 2.5 to 3.6 | | -70 | | dB |
| THD | Total Harmonic Distortion ⁽⁷⁾ | $R_T=32\ \Omega$, $V_{SW}=2\ \text{V}_{pk-pk}$, $f=20\ \text{Hz}$ to $20\ \text{kHz}$, $V_{BIAS}=0\ \text{V}$ | 2.5 | | 0.01 | | % |
| BW | S_{DD21} Differential -3 db Bandwidth ⁽⁷⁾ | $V_{IN}=1\ \text{V}_{pk-pk}$, Common Mode Voltage = $V_{CC} - 1.1\ \text{V}$, MHL Path, $R_L=50\ \Omega$, $C_L=0\ \text{pF}$, Figure 13 | 2.5 to 3.6 | | 2.0 | | GHz |
| | | $V_{IN}=400\ \text{mV}_{pk-pk}$, Common Mode Voltage = $0.2\ \text{V}$, USB Path, $R_L=50\ \Omega$, $C_L=0\ \text{pF}$, Figure 13 | | | 1.80 | | |
| | | AUDIO Path, $R_L=50\ \Omega$, $C_L=0\ \text{pF}$ | | | 50 | | MHz |

Note:

7. Guaranteed by characterization.

USB High-Speed AC Electrical Characteristics

All typical value are at $T_A=25^\circ\text{C}$ unless otherwise specified.

| Symbol | Parameter | Condition | V_{CC} (V) | Typ. | Unit |
|-------------|--|--|--------------|------|------|
| $t_{SK(P)}$ | Skew of Opposite Transitions of the Same Output ⁽⁸⁾ | $C_L=5\text{ pF}$, $R_L=50\ \Omega$, Figure 14 | 3.0 to 3.6 | 3 | ps |
| t_J | Total Jitter ⁽⁸⁾ | $R_L=50\ \Omega$, $C_L=5\text{ pf}$, $t_R=t_F=500\text{ ps}$ (10-90%) at 480 Mbps, PN7 | 3.0 to 3.6 | 15 | ps |

Note:

8. Guaranteed by characterization.

MHL AC Electrical Characteristics

All typical value are at $T_A=25^\circ\text{C}$ unless otherwise specified.

| Symbol | Parameter | Condition | V_{CC} (V) | Typ. | Unit |
|-------------|--|--|--------------|------|------|
| $t_{SK(P)}$ | Skew of Opposite Transitions of the Same Output ⁽⁹⁾ | $R_{PU}=50\ \Omega$ to V_{CC} , $C_L=0\text{ pF}$ | 3.0 to 3.6 | 3 | ps |
| t_J | Total Jitter ⁽⁹⁾ | $f=2.25\text{ Gbps}$, PN7, $R_{PU}=50\ \Omega$ to V_{CC} , $C_L=0\text{ pF}$ | 3.0 to 3.6 | 26 | ps |

Note:

9. Guaranteed by characterization.

Capacitance

All typical value are at $T_A=25^\circ\text{C}$ unless otherwise specified.

| Symbol | Parameter | Condition | Typ. | Unit |
|----------------|---|--|------|------|
| C_{IN} | Control Pin Input Capacitance ⁽¹⁰⁾ | $V_{CC}=0\text{ V}$, $f=1\text{ MHz}$ | 1.5 | pF |
| $C_{ON(USB)}$ | USB Path On Capacitance ⁽¹⁰⁾ | $V_{CC}=3.3\text{ V}$, $f=240\text{ MHz}$, Figure 15 | 6.5 | |
| $C_{OFF(USB)}$ | USB Path Off Capacitance ⁽¹⁰⁾ | $V_{CC}=3.3\text{ V}$, $f=240\text{ MHz}$, Figure 16 | 2.5 | |
| $C_{ON(MHL)}$ | MHL Path On Capacitance ⁽¹⁰⁾ | $V_{CC}=3.3\text{ V}$, $f=240\text{ MHz}$, Figure 15 | 6.5 | |
| $C_{OFF(MHL)}$ | MHL Path Off Capacitance ⁽¹⁰⁾ | $V_{CC}=3.3\text{ V}$, $f=240\text{ MHz}$, Figure 16 | 2.5 | |
| $C_{ON(AUD)}$ | Audio Path On Capacitance ⁽¹⁰⁾ | $V_{CC}=3.3\text{ V}$, $f=1\text{ MHz}$, Figure 15 | 8.0 | |
| $C_{OFF(AUD)}$ | Audio Path Off Capacitance ⁽¹⁰⁾ | $V_{CC}=3.3\text{ V}$, $f=1\text{ MHz}$, Figure 16 | 2.5 | |

Note:

10. Guaranteed by characterization.

Test Diagrams

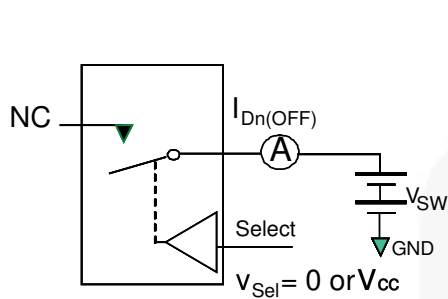

**Each switch port is tested separately

Figure 5. Off Leakage

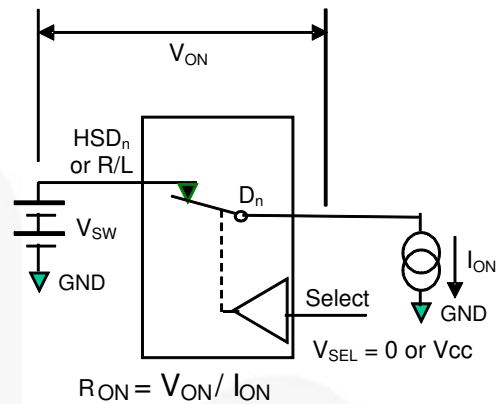

Figure 6. On Resistance

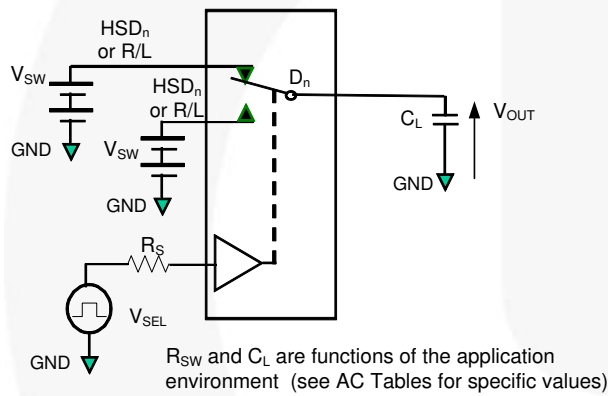

Figure 7. AC Test Circuit Load

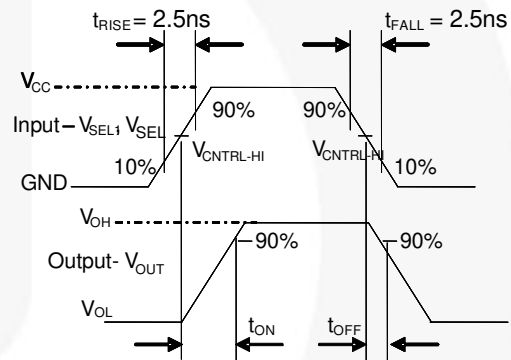

Figure 8. Turn-On / Turn-Off Waveforms

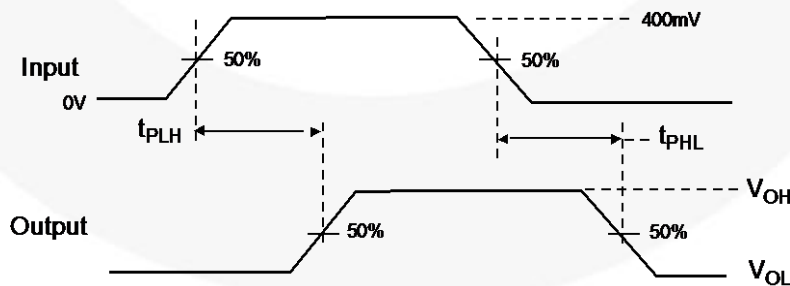

Figure 9. Propagation Delay ($t_{RtF} = 500ps$)

Note:

11. HSD_n refers to the high-speed data USB or MHL paths.

Test Diagrams

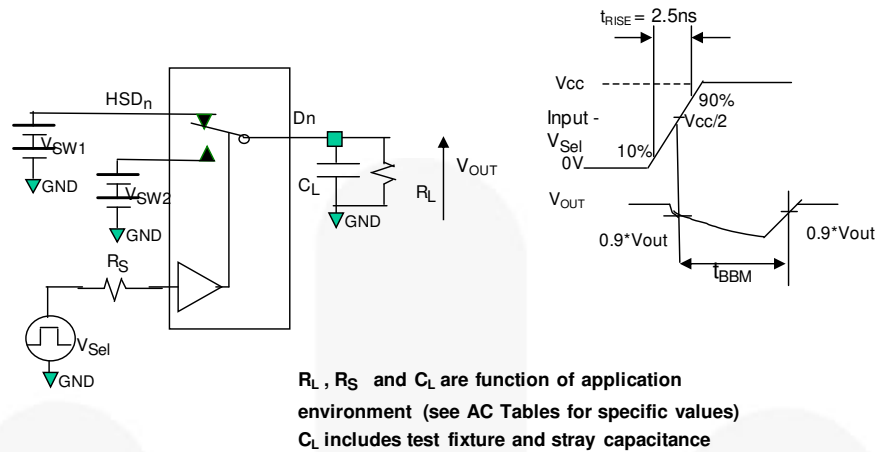

Figure 10. Break-Before-Make Interval Timing

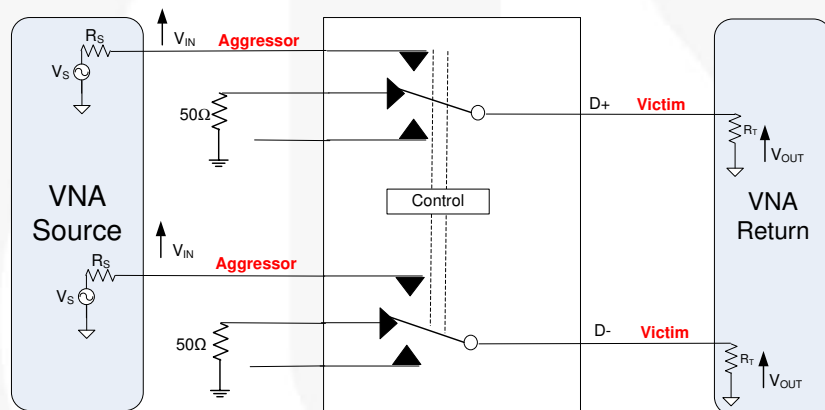

Figure 11. Channel Off Isolation (SDD21)

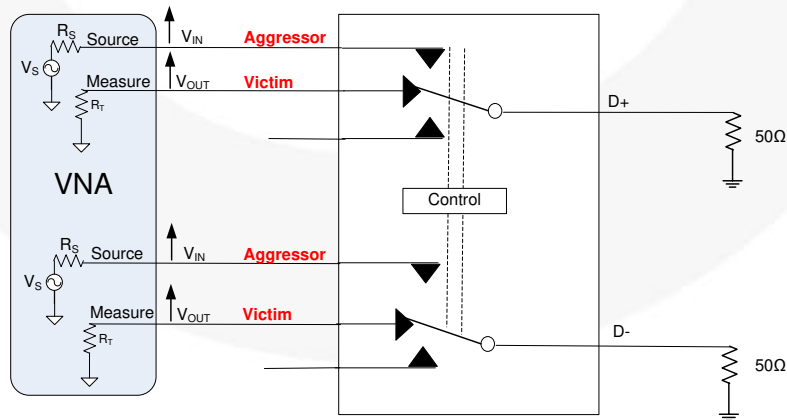
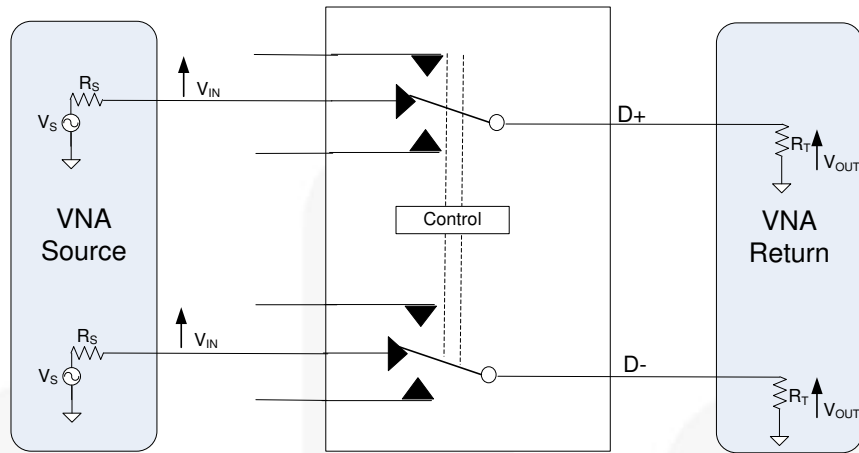

Figure 12. Non-Adjacent Channel-to-Channel Crosstalk (SDD21)

Test Diagrams



V_S , R_S and R_T are functions of the application environment (see AC/DC Tables for values).

Figure 13. Insertion Loss (SDD21)

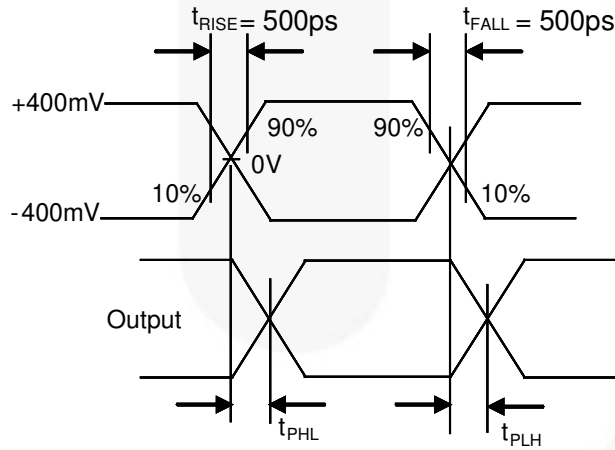

Figure 14. Intra-Pair Skew Test $t_{SK(P)}$

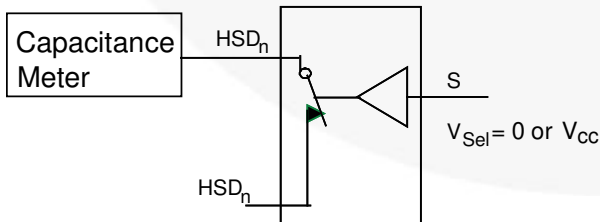

Figure 15. Channel On Capacitance

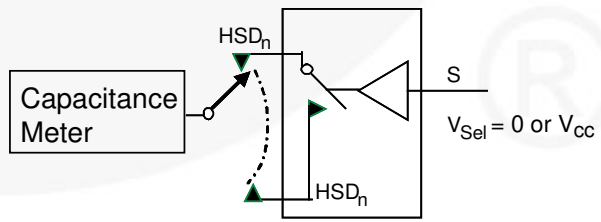

Figure 16. Channel Off Capacitance

Functional Description

Insertion Loss

One of the key factors for using the FSA3030 in mobile digital video applications is the small amount of insertion loss experienced by the received signal as it passes through the switch. This results in minimal degradation of the received eye. One of the ways to measure the quality of the high data rate channels is using balanced ports and four-port differential S-parameter analysis, particularly SDD21.

Bandwidth is measured using the S-parameter SDD21 methodology.



Figure 17. MHL Path SDD21 Insertion Loss Curve



Figure 18. USB Path SDD21 Insertion Loss Curve

Typical Applications

Figure 19 shows the FSA3030 utilizing the V_{BAT} connection. The 3M resistors are used to ensure, for manufacturing test via the micro-USB connector, that the FSA3030 configures for connectivity to the baseband or application processor.

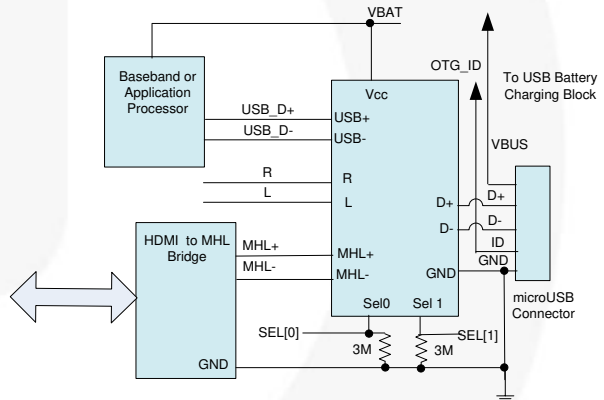
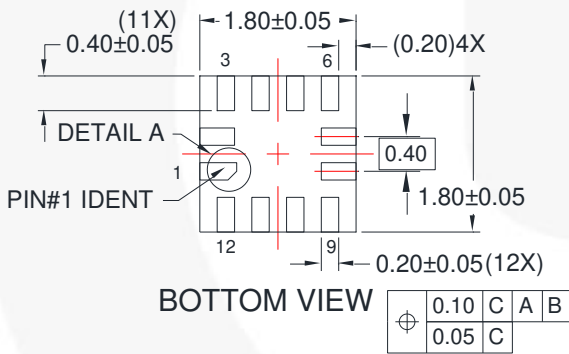
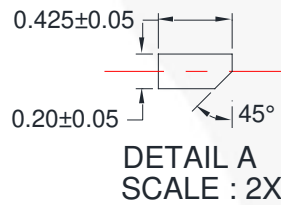
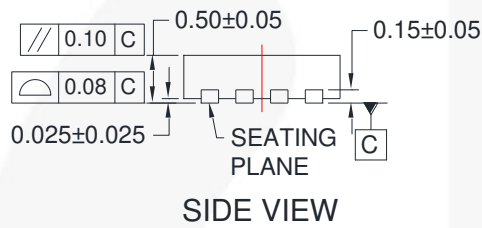
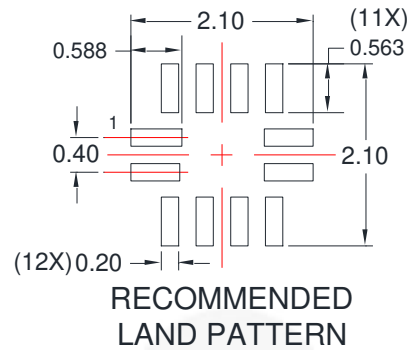
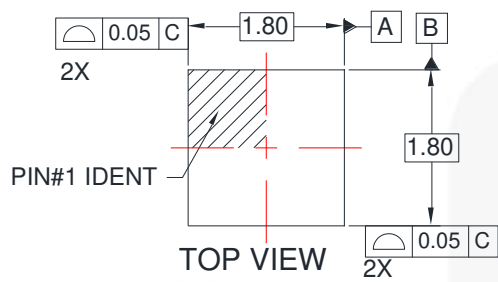

Figure 19. MHL Path SDD21 Insertion Loss Curve

Table 2. Product-Specific Package Dimensions

| Description | Nominal Values (mm) |
|--------------------------------------|---------------------------------|
| Overall Height | 0.50 |
| Package Standoff | 0.012 |
| Lead Thickness | 0.15 |
| Lead Width | 0.20 |
| Lead Length | 0.40 |
| Lead Pitch | 0.40 |
| Body Length (X) | Min: 1.70, Nom: 1.80, Max: 1.90 |
| Body Width (Y) | Min: 1.70, Nom: 1.80, Max: 1.90 |
| Lead One Nominal Length | 0.40 |
| Lead One Nominal Width | 0.20 |
| Lead One Nominal Bevel Length | 0.10 |
| Lead One Nominal Bevel Depth | 0.10 |
| Lead One Nominal Tip Non-Bevel Width | 0.10 |

Physical Dimensions



NOTES:

- A. PACKAGE DOES NOT CONFORM TO ANY JEDEC STANDARD.
- B. DIMENSIONS ARE IN MILLIMETERS.
- C. DIMENSIONS AND TOLERANCES PER ASME Y14.5M, 2009.
- D. LAND PATTERN RECOMMENDATION IS EXISTING INDUSTRY LAND PATTERN.
- E. DRAWING FILENAME: MKT-UMLP12Arev5.

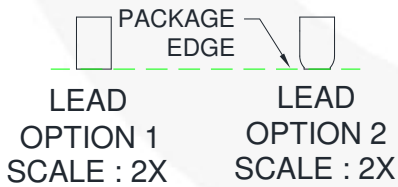

Figure 20. 12-Lead, Ultrathin Molded Leadless Package (UMLP)



TRADEMARKS

The following includes registered and unregistered trademarks and service marks, owned by Fairchild Semiconductor and/or its global subsidiaries, and is not intended to be an exhaustive list of all such trademarks.

| | | | |
|---|--|---|---|
| AccuPower™ | F-PFS™ |  |  |
| Awinda® | FRFET® | PowerTrench® | TinyBoost® |
| AX-CAP®* | Global Power Resource™ | PowerXS™ | TinyBuck® |
| BitSiC™ | GreenBridge™ | Programmable Active Droop™ | TinyCalc™ |
| Build it Now™ | Green FPS™ | QFET® | TinyLogic™ |
| CorePLUS™ | Green FPS™ e-Series™ | QS™ | TINYOPTO™ |
| CorePOWER™ | Gmax™ | Quiet Series™ | TinyPower™ |
| CROSSVOL™ | GTO™ | RapidConfigure™ | TinyPWM™ |
| CTL™ | IntelliMAX™ |  | TinyWire™ |
| Current Transfer Logic™ | ISOPLANAR™ | Saving our world, 1mW/kW at a time™ | TranSiC™ |
| DEUXPEED® | Making Small Speakers Sound Louder and Better™ | SignalWise™ | TriFault Detect™ |
| Dual Cool™ | MegaBuck™ | SmartMax™ | TRUECURRENT®* |
| EcoSPARK® | MICROCOUPLER™ | SMART START™ | µSerDes™ |
| EfficientMax™ | MicroFET™ | Solutions for Your Success™ |  |
| ESBC™ | MicroPak™ | SPM® | UHC® |
|  | MicroPak2™ | STEALTH™ | Ultra FRFET™ |
| Fairchild® | MillerDrive™ | SuperFET® | UniFET™ |
| Fairchild Semiconductor® | MotionMax™ | SuperSOT™-3 | VCX™ |
| FACT Quiet Series™ | MotionGrid® | SuperSOT™-6 | VisualMax™ |
| FACT® | MTi® | SuperSOT™-8 | VoltagePlus™ |
| FAST® | MTX® | SupreMOS® | XS™ |
| FastvCore™ | MVN® | SyncFET™ | Xsens™ |
| FETBench™ | mWSaver® | Sync-Lock™ | 仙童™ |
| FPS™ | OptoHIT™ | | |

* Trademarks of System General Corporation, used under license by Fairchild Semiconductor.

DISCLAIMER

FAIRCHILD SEMICONDUCTOR RESERVES THE RIGHT TO MAKE CHANGES WITHOUT FURTHER NOTICE TO ANY PRODUCTS HEREIN TO IMPROVE RELIABILITY, FUNCTION, OR DESIGN. TO OBTAIN THE LATEST, MOST UP-TO-DATE DATASHEET AND PRODUCT INFORMATION, VISIT OUR WEBSITE AT [HTTP://WWW.FAIRCHILDSEMI.COM](http://www.fairchildsemi.com). FAIRCHILD DOES NOT ASSUME ANY LIABILITY ARISING OUT OF THE APPLICATION OR USE OF ANY PRODUCT OR CIRCUIT DESCRIBED HEREIN; NEITHER DOES IT CONVEY ANY LICENSE UNDER ITS PATENT RIGHTS, NOR THE RIGHTS OF OTHERS. THESE SPECIFICATIONS DO NOT EXPAND THE TERMS OF FAIRCHILD'S WORLDWIDE TERMS AND CONDITIONS, SPECIFICALLY THE WARRANTY THEREIN, WHICH COVERS THESE PRODUCTS.

LIFE SUPPORT POLICY

FAIRCHILD'S PRODUCTS ARE NOT AUTHORIZED FOR USE AS CRITICAL COMPONENTS IN LIFE SUPPORT DEVICES OR SYSTEMS WITHOUT THE EXPRESS WRITTEN APPROVAL OF FAIRCHILD SEMICONDUCTOR CORPORATION.

As used herein:

- Life support devices or systems are devices or systems which, (a) are intended for surgical implant into the body or (b) support or sustain life, and (c) whose failure to perform when properly used in accordance with instructions for use provided in the labeling, can be reasonably expected to result in a significant injury of the user.
- A critical component in any component of a life support device, or system whose failure to perform can be reasonably expected to cause the failure of the life support device or system, or to affect its safety or effectiveness.

ANTI-COUNTERFEITING POLICY

Fairchild Semiconductor Corporation's Anti-Counterfeiting Policy. Fairchild's Anti-Counterfeiting Policy is also stated on our external website, www.fairchildsemi.com, under Sales Support.

Counterfeiting of semiconductor parts is a growing problem in the industry. All manufacturers of semiconductor products are experiencing counterfeiting of their parts. Customers who inadvertently purchase counterfeit parts experience many problems such as loss of brand reputation, substandard performance, failed applications, and increased cost of production and manufacturing delays. Fairchild is taking strong measures to protect ourselves and our customers from the proliferation of counterfeit parts. Fairchild strongly encourages customers to purchase Fairchild parts either directly from Fairchild or from Authorized Fairchild Distributors who are listed by country on our web page cited above. Products customers buy either from Fairchild directly or from Authorized Fairchild Distributors are genuine parts, have full traceability, meet Fairchild's quality standards for handling and storage and provide access to Fairchild's full range of up-to-date technical and product information. Fairchild and our Authorized Distributors will stand behind all warranties and will appropriately address any warranty issues that may arise. Fairchild will not provide any warranty coverage or other assistance for parts bought from Unauthorized Sources. Fairchild is committed to combat this global problem and encourage our customers to do their part in stopping this practice by buying direct or from authorized distributors.

PRODUCT STATUS DEFINITIONS

Definition of Terms

| Datasheet Identification | Product Status | Definition |
|--------------------------|-----------------------|---|
| Advance Information | Formative / In Design | Datasheet contains the design specifications for product development. Specifications may change in any manner without notice. |
| Preliminary | First Production | Datasheet contains preliminary data; supplementary data will be published at a later date. Fairchild Semiconductor reserves the right to make changes at any time without notice to improve design. |
| No Identification Needed | Full Production | Datasheet contains final specifications. Fairchild Semiconductor reserves the right to make changes at any time without notice to improve the design. |
| Obsolete | Not In Production | Datasheet contains specifications on a product that is discontinued by Fairchild Semiconductor. The datasheet is for reference information only. |

Rev. I71

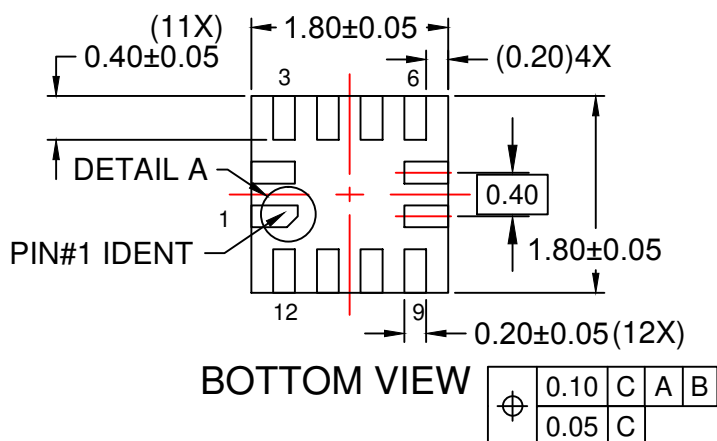
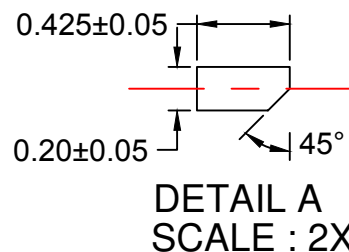
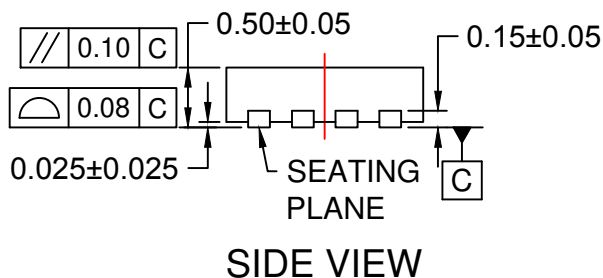
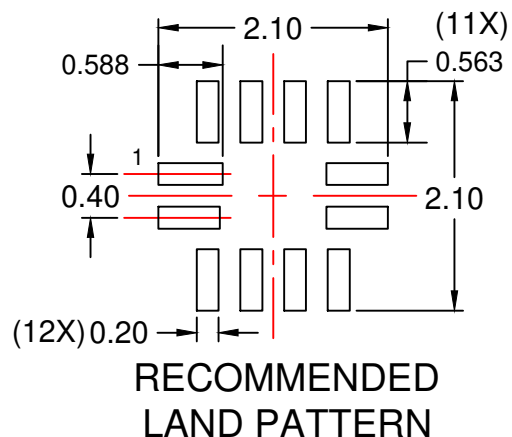
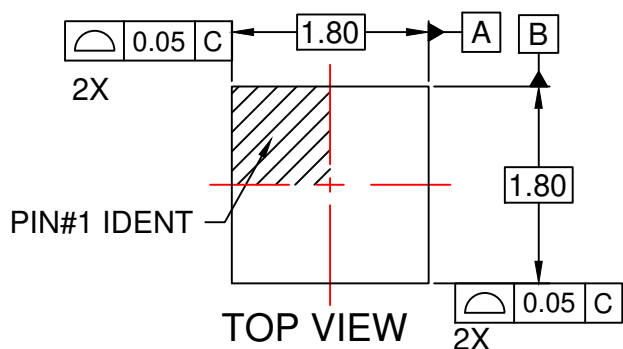

NOTES:

- A. PACKAGE DOES NOT CONFORM TO ANY JEDEC STANDARD.
- B. DIMENSIONS ARE IN MILLIMETERS.
- C. DIMENSIONS AND TOLERANCES PER ASME Y14.5M, 2009.
- D. LAND PATTERN RECOMMENDATION IS EXISTING INDUSTRY LAND PATTERN.
- E. DRAWING FILENAME: MKT-UMLP12Arev5.

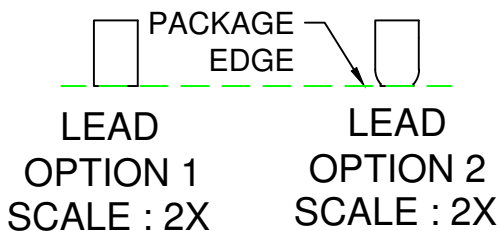



TRADEMARKS

The following includes registered and unregistered trademarks and service marks, owned by Fairchild Semiconductor and/or its global subsidiaries, and is not intended to be an exhaustive list of all such trademarks.

| | | | |
|--------------------------|--|---------------------------------------|------------------|
| AccuPower™ | F-PFS™ | OPTOPLANAR® | |
| AttitudeEngine™ | FRFET® | | TinyBoost® |
| Awinda® | Global Power Resource™ | PowerTrench® | TinyBuck® |
| AX-CAP®* | GreenBridge™ | PowerXS™ | TinyCalc™ |
| BitSiC™ | Green FPS™ | Programmable Active Droop™ | TinyLogic® |
| Build it Now™ | Green FPS™ e-Series™ | QFET® | TINYOPTO™ |
| CorePLUS™ | Gmax™ | QS™ | TinyPower™ |
| CorePOWER™ | GTO™ | Quiet Series™ | TinyPWM™ |
| CROSSVOLT™ | IntelliMAX™ | RapidConfigure™ | TinyWire™ |
| CTL™ | ISOPLANAR™ | | TranSiC™ |
| Current Transfer Logic™ | Making Small Speakers Sound Louder and Better™ | Saving our world, 1mW/W/kW at a time™ | TriFault Detect™ |
| DEUXPEED® | MegaBuck™ | SignalWise™ | TRUECURRENT®* |
| Dual Cool™ | MICROCOUPLER™ | SmartMax™ | SerDes™ |
| EcoSPARK® | MicroFET™ | SMART START™ | |
| EfficientMax™ | MicroPak™ | Solutions for Your Success™ | UHC® |
| ESBC™ | MicroPak2™ | SPM® | Ultra FRFET™ |
| | MillerDrive™ | STEALTH™ | UniFET™ |
| Fairchild® | MotionMax™ | SuperFET® | VCX™ |
| Fairchild Semiconductor® | MotionGrid® | SuperSOT™-3 | VisualMax™ |
| FACT Quiet Series™ | MTI® | SuperSOT™-6 | VoltagePlus™ |
| FACT® | MTX® | SuperSOT™-8 | XS™ |
| FAST® | MVN® | SupreMOS® | Xsens™ |
| FastvCore™ | mWSaver® | SyncFET™ | 仙童™ |
| FETBench™ | OptoHiT™ | Sync-Lock™ | |
| FPS™ | OPTOLOGIC® | | |

* Trademarks of System General Corporation, used under license by Fairchild Semiconductor.

DISCLAIMER

FAIRCHILD SEMICONDUCTOR RESERVES THE RIGHT TO MAKE CHANGES WITHOUT FURTHER NOTICE TO ANY PRODUCTS HEREIN TO IMPROVE RELIABILITY, FUNCTION, OR DESIGN. TO OBTAIN THE LATEST, MOST UP-TO-DATE DATASHEET AND PRODUCT INFORMATION, VISIT OUR WEBSITE AT [HTTP://WWW.FAIRCHILDSEMI.COM](http://www.fairchildsemi.com). FAIRCHILD DOES NOT ASSUME ANY LIABILITY ARISING OUT OF THE APPLICATION OR USE OF ANY PRODUCT OR CIRCUIT DESCRIBED HEREIN; NEITHER DOES IT CONVEY ANY LICENSE UNDER ITS PATENT RIGHTS, NOR THE RIGHTS OF OTHERS. THESE SPECIFICATIONS DO NOT EXPAND THE TERMS OF FAIRCHILD'S WORLDWIDE TERMS AND CONDITIONS, SPECIFICALLY THE WARRANTY THEREIN, WHICH COVERS THESE PRODUCTS.

LIFE SUPPORT POLICY

FAIRCHILD'S PRODUCTS ARE NOT AUTHORIZED FOR USE AS CRITICAL COMPONENTS IN LIFE SUPPORT DEVICES OR SYSTEMS WITHOUT THE EXPRESS WRITTEN APPROVAL OF FAIRCHILD SEMICONDUCTOR CORPORATION.

As used herein:

1. Life support devices or systems are devices or systems which, (a) are intended for surgical implant into the body or (b) support or sustain life, and (c) whose failure to perform when properly used in accordance with instructions for use provided in the labeling, can be reasonably expected to result in a significant injury of the user.
2. A critical component in any component of a life support, device, or system whose failure to perform can be reasonably expected to cause the failure of the life support device or system, or to affect its safety or effectiveness.

ANTI-COUNTERFEITING POLICY

Fairchild Semiconductor Corporation's Anti-Counterfeiting Policy. Fairchild's Anti-Counterfeiting Policy is also stated on our external website, www.fairchildsemi.com, under Sales Support.

Counterfeiting of semiconductor parts is a growing problem in the industry. All manufacturers of semiconductor products are experiencing counterfeiting of their parts. Customers who inadvertently purchase counterfeit parts experience many problems such as loss of brand reputation, substandard performance, failed applications, and increased cost of production and manufacturing delays. Fairchild is taking strong measures to protect ourselves and our customers from the proliferation of counterfeit parts. Fairchild strongly encourages customers to purchase Fairchild parts either directly from Fairchild or from Authorized Fairchild Distributors who are listed by country on our web page cited above. Products customers buy either from Fairchild directly or from Authorized Fairchild Distributors are genuine parts, have full traceability, meet Fairchild's quality standards for handling and storage and provide access to Fairchild's full range of up-to-date technical and product information. Fairchild and our Authorized Distributors will stand behind all warranties and will appropriately address any warranty issues that may arise. Fairchild will not provide any warranty coverage or other assistance for parts bought from Unauthorized Sources. Fairchild is committed to combat this global problem and encourage our customers to do their part in stopping this practice by buying direct or from authorized distributors.

PRODUCT STATUS DEFINITIONS

Definition of Terms

| Datasheet Identification | Product Status | Definition |
|--------------------------|-----------------------|---|
| Advance Information | Formative / In Design | Datasheet contains the design specifications for product development. Specifications may change in any manner without notice. |
| Preliminary | First Production | Datasheet contains preliminary data; supplementary data will be published at a later date. Fairchild Semiconductor reserves the right to make changes at any time without notice to improve design. |
| No Identification Needed | Full Production | Datasheet contains final specifications. Fairchild Semiconductor reserves the right to make changes at any time without notice to improve the design. |
| Obsolete | Not In Production | Datasheet contains specifications on a product that is discontinued by Fairchild Semiconductor. The datasheet is for reference information only. |

Rev. I73