

BWLM Series



BWLM Series is the newest in open type ferrite wire wound chip inductors. The wire wound ferrite construction supports higher SRF, lower DCR and superior Q values than other ferrite chip inductors.

Features

- RoHS compliant
- Very strong solderability by reflow soldering and soldering iron
- Highly accurate dimensions
- Can be mounted automatically
- Terminals are highly resistant to external forces
- Highly resistant to mechanical shocks and pressure
- Highly reliable in environments of sudden temperature change and humidity
- Low DCR & better Q value in ferrite series

Applications

- Telecom and datacom applications such as xDSL
- Cable modem
- Set-top box
- CATV filter/tuner
- Wireless LAN, etc

Product Identification

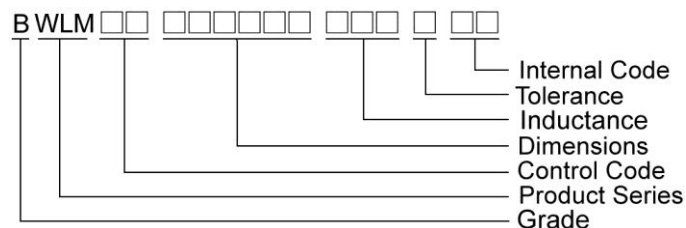

Shape and Dimensions / Recommended Pattern

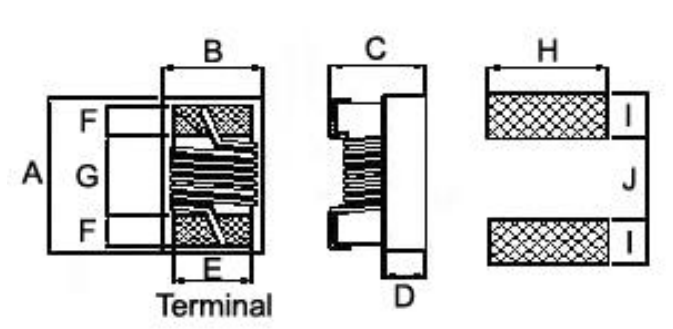

Dimensions in mm

TYPE	A	B	C	D	E	F	G	H	I	J
BWLM00110706	1.1±0.1	0.7±0.1	0.6±0.1	0.25	0.5	0.25	0.5	0.6	0.50	0.4
BWLM00181009	1.8±0.1	1.0±0.1	0.9±0.1	0.60	0.8	0.40	0.85	1.0	0.75	0.7

SMD Wire Wound Ferrite Chip Inductors – BWLM Series

Electrical Characteristics

Part Number	Inductance (nH)	Tolerance (±%)	Test Frequency (MHz)	SRF (MHz) Min	RDC (Ω) Max	I _{rms} (mA) Max
BWLM0011070618N□00	18	5	100	3000	0.046	1400
BWLM0011070633N□00	33	5	100	1800	0.065	1300
BWLM0011070648N□00	48	5	100	1400	0.078	1100
BWLM0011070670N□00	70	5	100	1300	0.12	820
BWLM0011070696N□00	96	5	100	1100	0.16	730
BWLM00110706R13□00	130	5	100	1000	0.23	640
BWLM00110706R16□00	160	5	100	900	0.33	480
BWLM00110706R20□00	200	5	100	800	0.47	390

Note: When ordering, please specify tolerance code. Tolerance : J=±5%

- Operating temperature range - 40°C ~ 125°C(Including self - temperature rise)
- I_{rms} for a 20°C temperature rise from 25°C ambient with current
- Measure Equipment :
 L & Q : Agilent E4991A+Agilent HP16197A
 SRF : Agilent E4991A
 RDC : HP4338B or Chroma 16502
 I_{rms} : HP4284A+HP42841A/HP4285A+HP42841A
- Offset value : -0.556nH

Test Instruments : Agilent E4991A Material/Impedance Analyzer

Typical L vs. Frequency

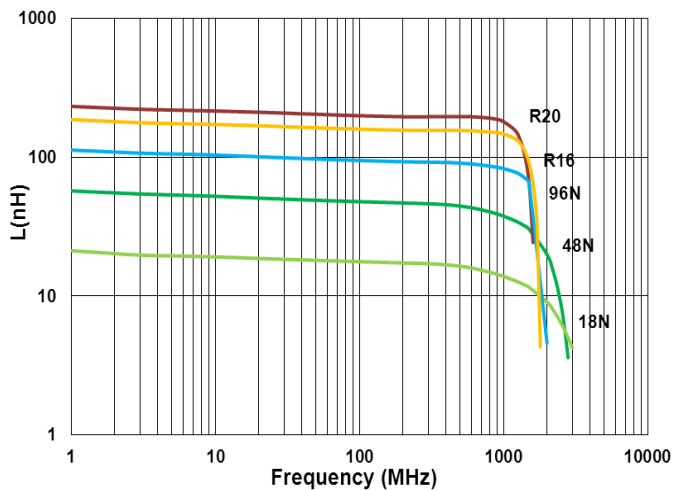

Typical Q vs. Frequency

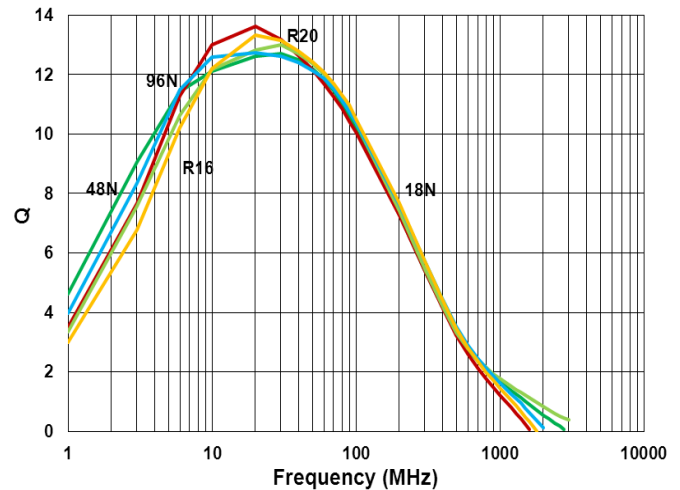

SMD Wire Wound Ferrite Chip Inductors – BWLM Series

Electrical Characteristics

Part Number	Inductance (nH)	Tolerance (±%)	Test Frequency (MHz)	SRF (MHz) Min	RDC (Ω) Max	I _{rms} (mA) Max
BWLM001810094N9□00	4.9	±0.5nH	10	2300	0.015	2600
BWLM0018100915N□00	15	5	10	2000	0.025	2200
BWLM0018100933N□00	33	5	10	1800	0.035	1700
BWLM0018100955N□00	55	5	10	1600	0.045	1500
BWLM0018100985N□00	85	5	10	1380	0.060	1400
BWLM00181009R10□00	100	10	10	1260	0.10	1000
BWLM00181009R12□00	120	5	10	1200	0.085	1100
BWLM00181009R16□00	160	5	10	900	0.10	1000
BWLM00181009R21□00	210	5	10	720	0.15	800
BWLM00181009R27□00	270	5	10	660	0.16	750
BWLM00181009R33□00	330	5	10	600	0.25	630
BWLM00181009R39□00	390	5	10	570	0.28	620
BWLM00181009R47□00	470	5	10	555	0.45	500
BWLM00181009R56□00	560	5	10	540	0.48	450
BWLM00181009R65□00	650	5	10	510	0.52	430

Note: When ordering, please specify tolerance code. Tolerance : D=±0.5nH , J=±5% , K=±10%

- Operating temperature range - 40°C ~ 125°C(Including self - temperature rise)
- I_{rms} for a 20°C temperature rise from 25°C ambient with current
- Measure Equipment :
L & Q : Agilent E4991A+Agilent HP16197A
SRF : Agilent E4991A
RDC : HP4338B or Chroma 16502
I_{rms} : HP4284A+HP42841A/HP4285A+HP42841A
- Offset value : -0.771nH

Test Instruments : Agilent E4991A Material/Impedance Analyzer

Typical L vs. Frequency

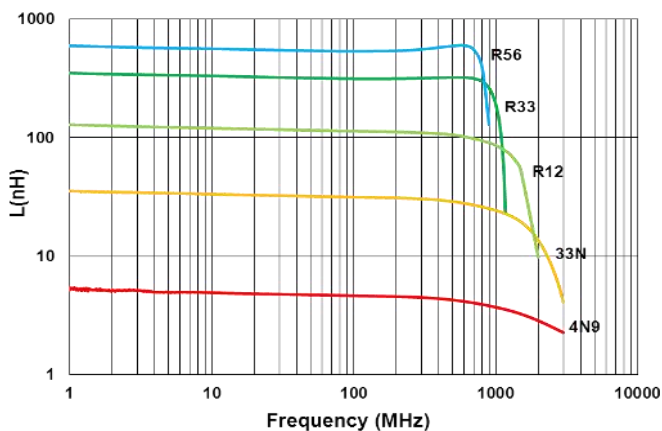

Typical Q vs. Frequency

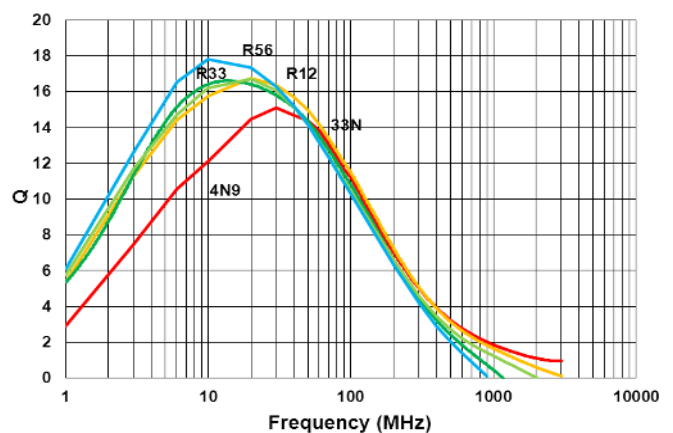

Please be sure to request approval specifications that provide further details of the products. Kindly note that the content of these specifications are subject to change or may be discontinued without prior notice. This product may not be designed/used in medical or high risk applications without Chilisin approval. Please contact our sales department before ordering.

SMD Wire Wound Ferrite Chip Inductors - BWLM Series

Packaging Specifications

Tape Dimensions

Figure 1

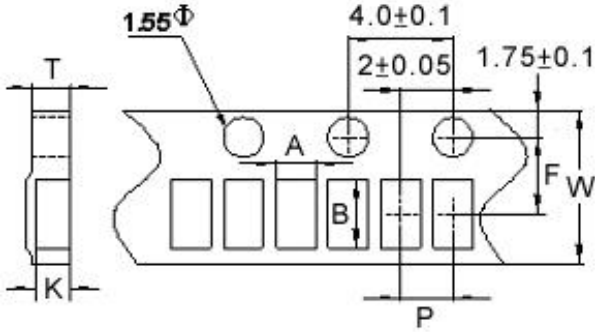
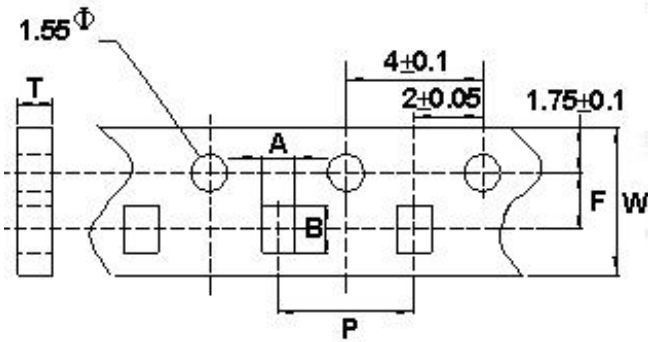
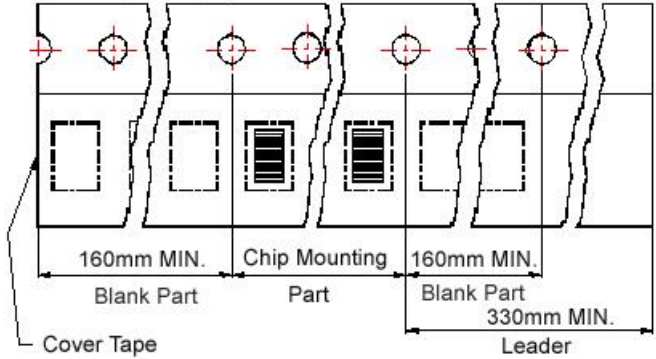

Figure 2



Tape Material

Carrier Tape: Paper
Cover Tape: Polystyrene



Carrier Tape: Paper
Cover Tape: Polystyrene

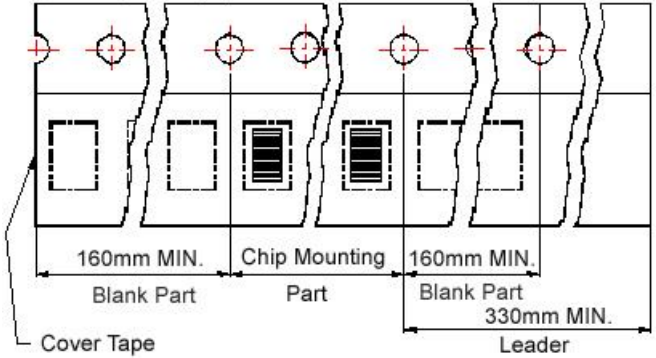

Reel Dimensions

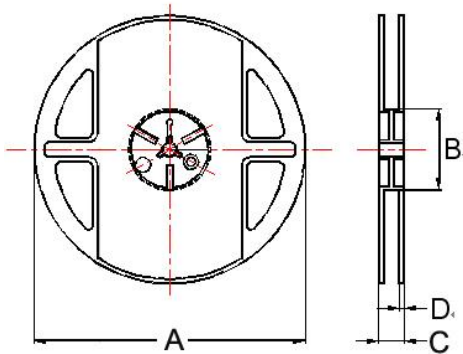

Dimensions in mm

TYPE	Fig.	Tape Dimensions							Reel Dimensions				Quantity PCS / REEL
		A	B	T	W	P	F	K	A	B	C	D	
BWLM00110706	1	0.8	1.2	0.75	8	2	3.5	0.62	178	60	12	1.5	4000
BWLM00181009	2	1.2	2.0	1.1	8	4	3.5	-	178	60	12	1.5	4000