



# MAX9926U Evaluation Kit

## General Description

The MAX9926U evaluation kit (EV kit) is a fully assembled and tested circuit board that contains a dual-channel differential variable-reluctance (VR or magnetic pickup) sensor interface circuit using a MAX9926U IC in a 16-pin QSOP package. The dual-channel interface circuit also features differential amplifiers for evaluating a pair of differential or single-ended VR sensor signals and provides a gain of 1. Input power to the EV kit circuit can be supplied by a 4.5V to 5.5V DC source. The MAX9926U IC temperature range is -40°C to +125°C. The EV kit uses automotive power-train safety-equipment-rated ceramic capacitors with a temperature range of -55°C to +125°C.

The MAX9926U EV kit circuit can be configured to demonstrate the MAX9926U IC's operation with internal adaptive peak threshold and zero-crossing detection modes, as well as to interface to a microcontroller pulse-width modulation (PWM) signal for evaluating external thresholds. It can interface to both differential as well as single-ended VR sensors. The EV kit can evaluate external VR signals from 5Hz to 25kHz.

## Features

- ◆ Demonstrates the Operation of MAX9926U Modes A1, A2, and B
- ◆ Evaluates Dual Differential and Single-Ended Variable-Reluctance (VR or Magnetic Pickup) Sensors
- ◆ Demonstrates Zero Crossing, Peak Detection, Adaptive Threshold Mechanism, and Rotation Direction
- ◆ Includes Lowpass Sensor Input Filters
- ◆ Evaluates 5Hz to 25kHz VR Sensors
- ◆ Fully Assembled and Tested

## Ordering Information

PART	TYPE
MAX9926UEVKIT+	EV Kit

+Denotes lead(Pb)-free and RoHS compliant.

## Component List

DESIGNATION	QTY	DESCRIPTION
C1, C7	0	Not installed, ceramic capacitors (0805)
C2	1	4.7μF ±20%, 25V X7R ceramic capacitor (1206) Murata GCM31CR71E475M
C3, C10, C11	3	0.1μF ±10%, 50V X7R ceramic capacitors (0805) Murata GCM21BR71H104K
C4, C6, C9	3	1μF ±10%, 16V X7R ceramic capacitors (0805) Murata GCM219R71C105K
C8	1	0.1μF ±10%, 16V X7R ceramic capacitor (0603) Murata GCM188R71C104K
R1-R4, R14-R17	8	4.99kΩ ±1% resistors (1206) Panasonic ERJ-8ENF4991V
R5, R6, R18, R19	0	Not installed, resistors (0805)

DESIGNATION	QTY	DESCRIPTION
R10, R11	2	1kΩ ±1% resistors (0805)
R23, R28	2	10kΩ ±1% resistors (0805)
R24, R27, R29	3	10kΩ ±5% resistors (0805)
JU1, JU4, JU7 JU10	4	2-pin headers
JU2, JU3, JU5, JU6, JU8, JU9	6	3-pin headers
TP1, TP2, TP5, TP6	4	Miniature PC test points, yellow
TP3, TP4	2	Miniature PC test points, red
TP7, TP8	2	PC test points, black
U1	1	VR sensor interface (16 QSOP) Maxim MAX9926UAEE+ (Top Mark: +YWW)
—	10	Shunts (JU1-JU10)
—	1	PCB: MAX9926U EVALUATION KIT+

Evaluates: MAX9926U

# MAX9926U Evaluation Kit

## Component Suppliers

SUPPLIER	PHONE	WEBSITE
Murata Electronics North America, Inc.	770-436-1300	www.murata-northamerica.com
Panasonic Corp.	800-344-2112	www.panasonic.com

**Note:** Indicate that you are using the MAX9926U when contacting these component suppliers.

### Quick Start

#### Required Equipment

- MAX9926U EV kit
- 5V, 100mA power supply
- Oscilloscope
- Function generator

#### Procedure

The MAX9926U EV kit is fully assembled and tested. Follow the steps below to verify board operation.

**Caution: Do not turn on the power supply until all connections are completed.**

- 1) Verify that shunts are installed on their respective jumper, as shown in Table 1.
- 2) Connect the 5V power supply to the VCC pad and the power supply's ground to the GND pad.
- 3) Turn on the power supply.
- 4) Using the oscilloscope, measure the signal at the COUT1 or COUT2 and GND pads, which should be a 2.5kHz square waveform with amplitude of 5V.
- 5) Connect the function generator to the SENSE1+ and SENSE1- PCB pads.

6) Turn on the function generator and set it for an output of a DC offset of 2.5V DC, triangle wave with a frequency of 2.5kHz, and a 50% duty cycle.

7) The EV kit circuit is ready for further evaluation using two VR or magnetic pickup sensors. See the *Jumper Selection* section for configuring the EV kit circuit.

### Detailed Description of Hardware

The MAX9926U EV kit features a dual-channel differential VR sensor interface circuit using a MAX9926U IC in a 16-pin QSOP surface-mount package. The EV kit's dual-channel interface circuit can evaluate signals from differential or single-ended sensors. The interface circuit provides a gain of 1 and can evaluate differential sensor signal amplitudes of 50mV<sub>P-P</sub> to 300V<sub>P-P</sub> with a 5Hz to 25kHz frequency range. Power for the EV kit circuit can be supplied by a 4.5V to 5.5V DC source, which provides at least 100mA.

The MAX9926U EV kit circuit can be configured to demonstrate the MAX9926U Modes A1, A2, or B operation. Resistor-capacitor networks R10, R11, C4 provide a VCC/2 source to the BIAS1 and BIAS2 inputs, respectively, for evaluating Mode B. Refer to the *Mode Selection* section in the MAX9926U IC data sheet for additional

**Table 1. Default Jumper Configuration (JU1–JU10)**

JUMPER	SHUNT POSITION	JUMPER CONFIGURATION
JU1	Installed	Channel 1, single-ended sensor
JU2	1-2	Channel 1, Mode A1 mode of operation
JU3	1-2	Channel 2, Mode A1 mode of operation
JU4	Installed	Channel 2, single-ended sensor
JU5	1-2	Channel 1, Mode A1 mode of operation
JU6	1-2	Channel 1, Mode A1 mode of operation
JU7	Not installed	Mode A1 mode of operation
JU8	1-2	Channel 2, Mode A1 mode of operation
JU9	1-2	Channel 2, Mode A1 mode of operation
JU10	Installed	V_PULL VCC powered

# MAX9926U Evaluation Kit

**Evaluates: MAX9926U**

information on the modes of operation. Lowpass sensor input filtering for channel 1 SENSE1± inputs is provided by resistors-capacitor network R1–R4, C1 and channel 2 SENSE2± inputs are provided by R14–R17, C7. PCB pads provide access to the MAX9926U square-wave open-drain output signals at COUT1 and COUT2 and the direction signals. These outputs are pulled up to the V\_PULL voltage and are configurable by jumper JU10.

Additionally, PCB pads FILTER1 and FILTER2 are provided for interfacing with user-supplied microcontroller PWM signals when evaluating Mode B of the MAX9926U, which enables the threshold voltage to be set externally. For FILTER1, resistor-capacitor network R23, C10 and for FILTER2, R28, C11 provide a lowpass filter for the PWM input signals, respectively. Refer to the *Adaptive Peak Threshold* section in the MAX9926U IC data sheet for additional information.

When fed a 5Hz signal, the EV kit circuit can be used to demonstrate the MAX9926U's internal watchdog timer's functionality.

The EV kit also features test points to ease evaluating the raw sensor input signals. Tests points TP1 and TP2 provide access to the SENSE1+/SENSE1- input signals

after passing through resistors R1–R4. TP5 and TP6 provide access to the SENSE2+/SENSE2- input signals after passing through resistors R14–R17. TP3 and TP4 provide access to the BIAS1 and BIAS2 reference, respectively, while TP7 and TP8 provide access to GND.

## Jumper Selection

The MAX9926U EV kit features several jumpers to reconfigure the sensor input type, pullup voltage, and the interface circuit's mode of operation.

## Sensor Signal Sources (SENSE1+/SENSE1-, SENSE2+/SENSE2-)

The sensor signals are applied to the EV kit's channel 1 SENSE1+/SENSE1- and channel 2 SENSE2+/SENSE2- PCB pads. For proper operation, the typical differential sensor signal should have 50mV<sub>P-P</sub> to 300V<sub>P-P</sub> and a 5Hz to 25kHz frequency range. When evaluating single-ended sensors, resistors R1–R4 and R14–R17 require replacement for operation at higher voltages and power. Table 2 lists SENSE1+/SENSE1- various jumper options for selecting the signal source and Table 3 lists SENSE2+/SENSE2- jumper options.

**Table 2. Channel 1 SENSE1+/SENSE1- Source (JU1 Configuration)**

SHUNT POSITION	IN1+ PIN	IN1- PIN	SENSE1+/SENSE1- SOURCE
Not installed	Connected to SENSE1+ PCB pad through resistors R1 and R2	Connected to SENSE1- PCB pad through resistors R3 and R4	External differential VR sensor
Installed	Connected to SENSE1+ PCB pad through resistors R1 and R2	Connects SENSE1- PCB pad to GND pad	External single-ended VR sensor

**Table 3. Channel 2 SENSE2+/SENSE2- Source (JU4 Configuration)**

SHUNT POSITION	IN2+ PIN	IN2- PIN	SENSE2+/SENSE2- SOURCE
Not installed	Connected to SENSE2+ PCB pad through resistors R14 and R15	Connected to SENSE2- PCB pad through resistors R16, R17	External differential VR sensor
Installed	Connected to SENSE2+ PCB pad through resistors R14 and R15	Connects SENSE2- PCB pad to GND pad	External single-ended VR sensor

# MAX9926U Evaluation Kit

## MAX9926U Mode A1, A2, and B Operation

The MAX9926U EV kit features jumpers to configure the respective channel 1 and channel 2 VR sensor interface circuit mode of operation. The circuit can be configured for Mode A1, A2, or B operation. For channel 1, Table 4 lists the various jumper options for configuring the circuit. Table 5 lists channel 2 options;

**Mode B Operation:** Supply a digital PWM signal to the respective channel FILTER\_ and GND pads. The signal must provide a 5V logic-high frequency in the 25kHz to 100kHz range.

Refer to the *Mode Selection* section in the MAX9926U IC data sheet for additional information on selecting a mode of operation.

## COUT1, COUT2, DIRN Outputs and V\_PULL

The MAX9926U open-drain comparator outputs are available at the COUT1, COUT2, and DIRN PCB pads. The V\_PULL PCB pad is provided to pull up the COUT1, COUT2, and DIRN signals (R24, R29, and R27, respectively) to the voltage connected to the V\_PULL PCB pad. V\_PULL can accept voltages up to 5.5V after removing jumper JU10. When installed, jumper JU10 pulls the V\_PULL pads up to VCC.

**Table 4. Channel 1 Mode A1, A2, and B (JU1, JU2, JU5, JU6, JU7 Configuration)**

MODE	SHUNT POSITION				
	JU1 SENSOR	JU2 BIAS1	JU5 INT_THRS1	JU6 EXT1	JU7 ZERO_EN
A1	See Table 2	1-2	1-2	1-2	Not installed
A2	See Table 2	2-3	2-3	1-2	Installed
B	See Table 2	1-2	2-3	1-3	Not installed

**Table 5. Channel 2 Mode A1, A2, and B (JU3, JU4, JU7, JU8, JU9 Configuration)**

MODE	SHUNT POSITION				
	JU4 SENSOR	JU3 BIAS2	JU8 INT_THRS2	JU9 EXT2	JU7 ZERO_EN
A1	See Table 3	1-2	1-2	1-2	Not installed
A2	See Table 3	2-3	2-3	1-2	Installed
B	See Table 3	1-2	2-3	1-3	Not installed

# MAX9926U Evaluation Kit

Evaluates: MAX9926U

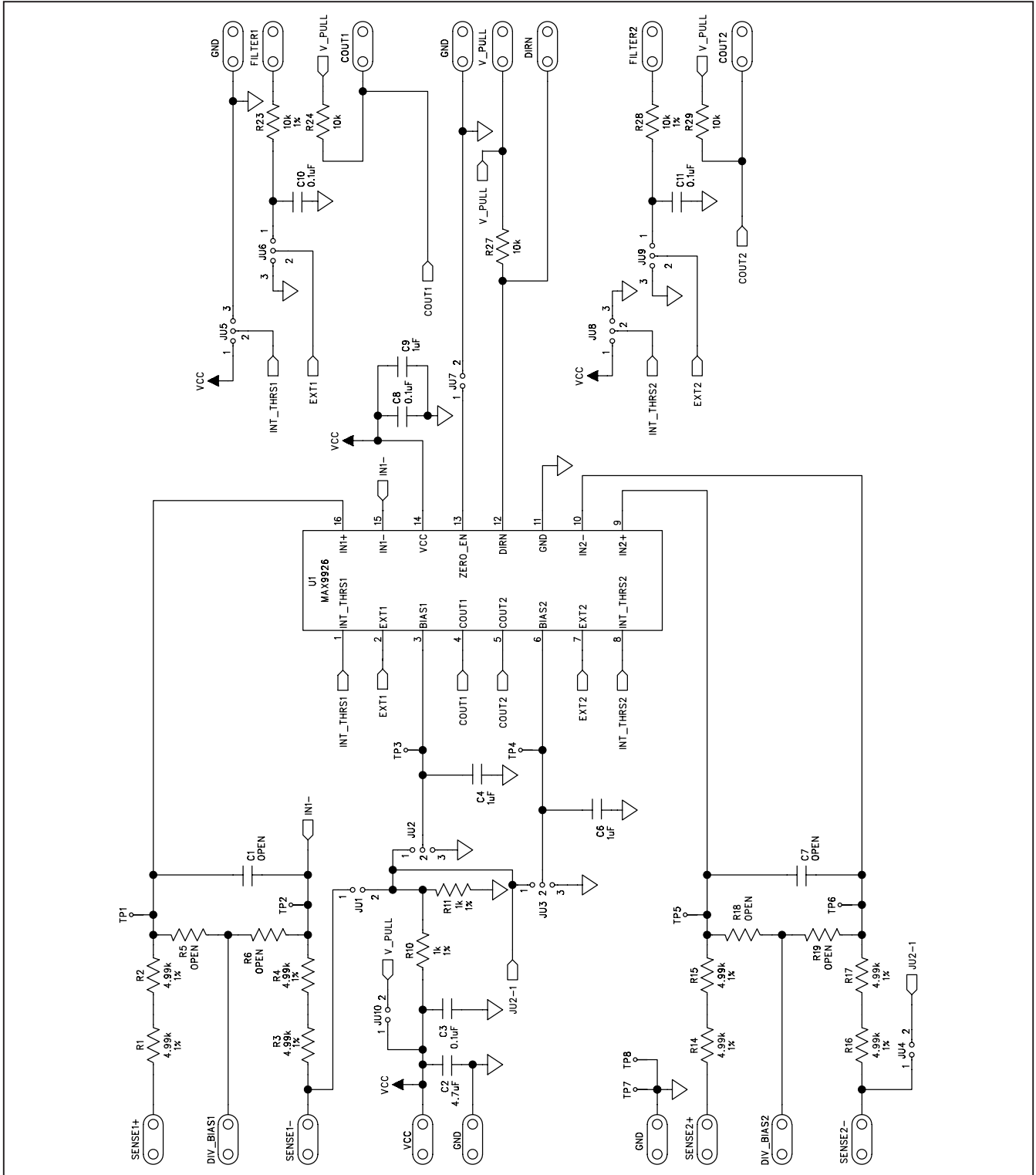

Figure 1. MAX9926U EV Kit Schematic

# MAX9926U Evaluation Kit

Evaluates: MAX9926U

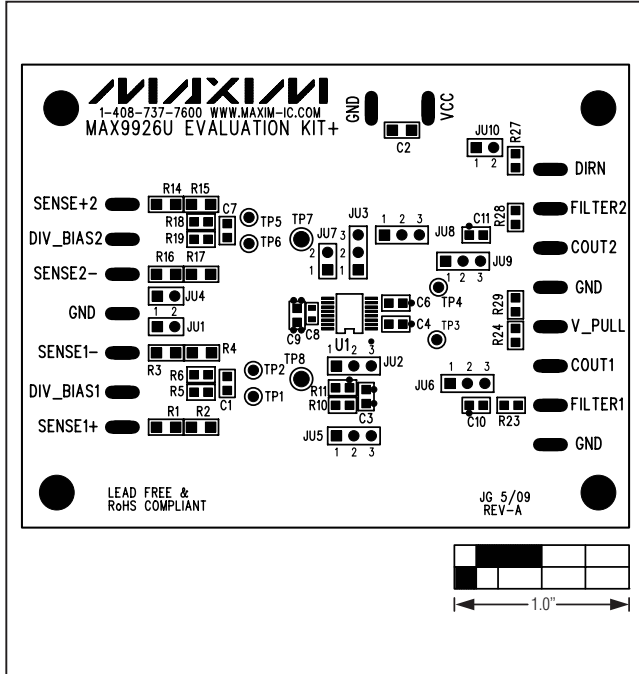

Figure 2. MAX9926U EV Kit Component Placement Guide—Component Side

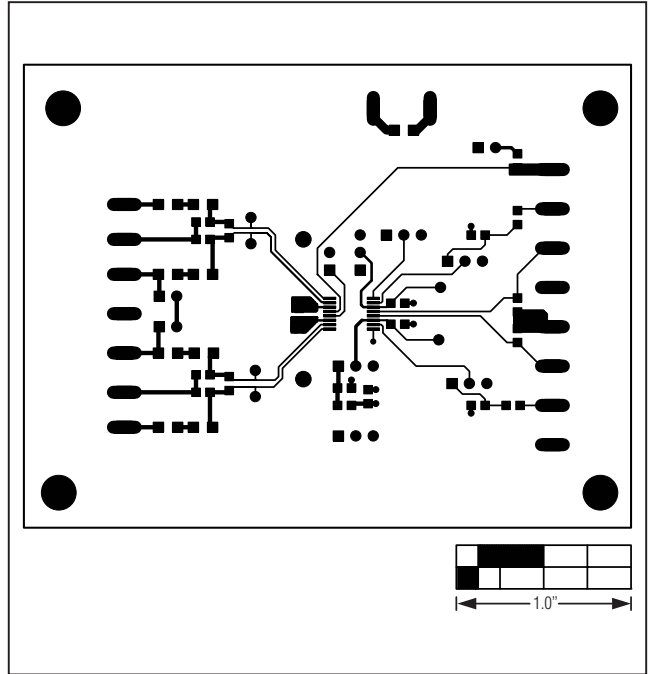

Figure 3. MAX9926U EV Kit PCB Layout—Component Side

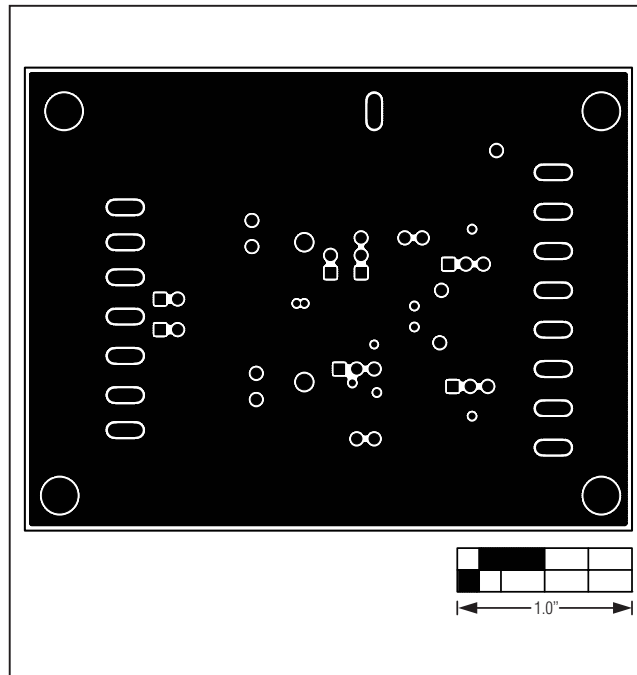

Figure 4. MAX9926U EV Kit PCB Layout—VCC Layer 2

# MAX9926U Evaluation Kit

Evaluates: MAX9926U

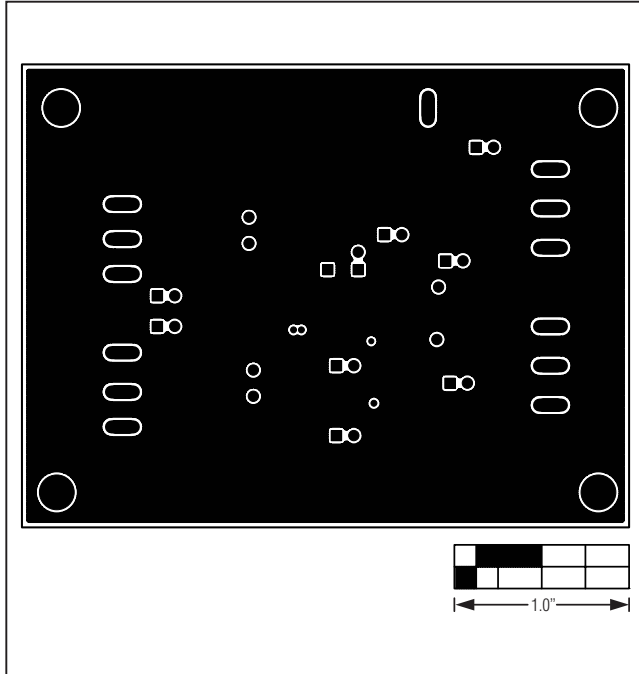

Figure 5. MAX9926U EV Kit PCB Layout—GND Layer 3

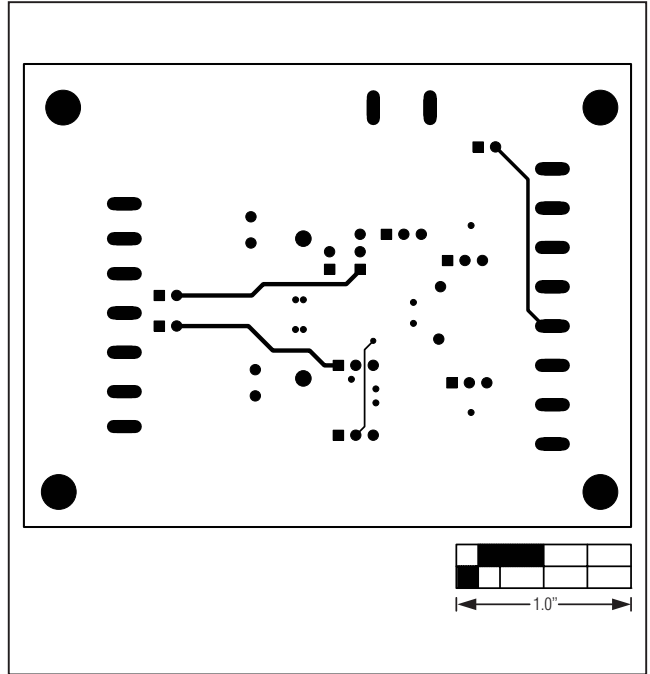

Figure 6. MAX9926U EV Kit PCB Layout—Solder Side

Maxim cannot assume responsibility for use of any circuitry other than circuitry entirely embodied in a Maxim product. No circuit patent licenses are implied. Maxim reserves the right to change the circuitry and specifications without notice at any time.

**Maxim Integrated Products, 120 San Gabriel Drive, Sunnyvale, CA 94086 408-737-7600** \_\_\_\_\_ 7