

PART NUMBER	REV	FIRST USED
567301-1	E	122500-1
567301-2	E	565435-5

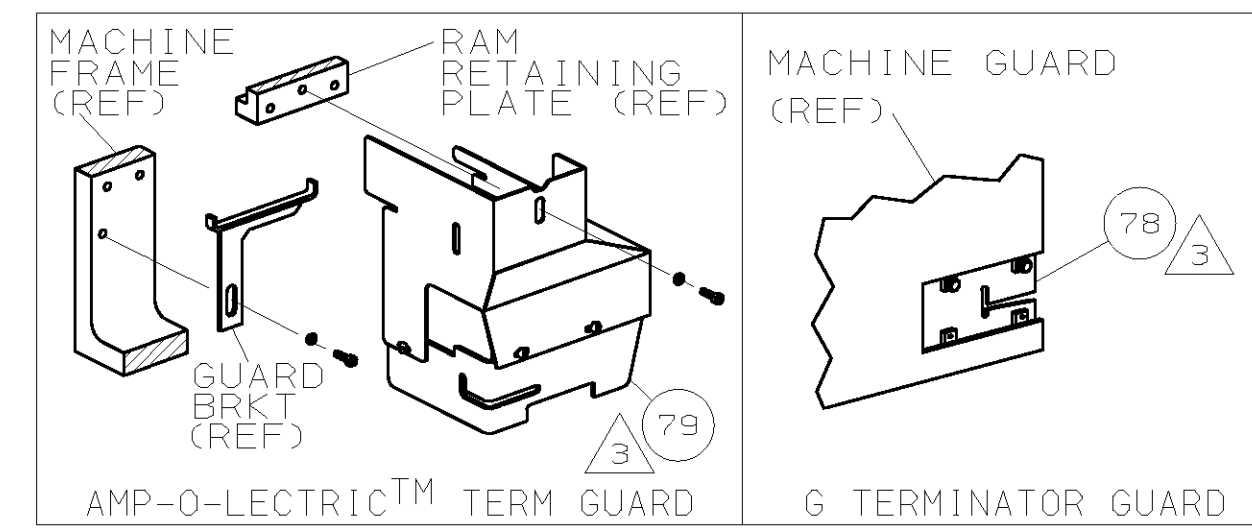

TERMINAL NAME: CLUSTER PIN RECEPTACLE		770430		CRIMPING DATA	
PAD LTR	CRIMP HEIGHT	WIRE SIZE			
A	.054 ±.002 [1.37 ±0.05mm]	18			
B	.050 ±.002 [1.27 ±0.05mm]	20			
C	.046 ±.002 [1.17 ±0.05mm]	22			
D	NOT	USED			
CRIMP	SIZE	TYPE	RANGE		
WIRE	.090 [2.29mm]	F	22-18		
INSUL	-	-	-		
WIRE STRIP LENGTH	TERM APPL SPEC	FEED	APPL INSTRUCTION	SET UP GAGE	LAYOUT
-	114-1025	.630		458638-1	L500

QTY	REV	U/M	DWG SIZE	PART NO	DESCRIPTION	ITEM NO
-1	-	-	-	LEADMAKER & BENCH MODEL G	AIRFEED	
-2	-	-	-	BENCH MODEL K	AIRFEED	
1	-	-	-	C	692655-5	AIR FEED VALVE ASSY
REF	-	-	-	A	24042-2	VALVE, SHUT OFF
REF	-	-	-	C	692655-6	AIR FEED VALVE ASSY
1	1	-	-	B	460277-1	AIR FEED ASSY (1 INCH)
2	2	-	-	A	3-21000-9	SCR, 5HC (10-32x1.00) AIR ASSY
-	1	-	-	A	983427-6	ELBOW, SWIVEL 1/8 NPT - 1/4 T
-	1	-	-	A	23238-1	QUICK DISCONNECT
-	12.00	IN	-	A	27319-4	TUBING, POLY-FLO Ø.25
1	1	-	-	C	454220-1	CAP, RAM
1	1	-	-	D	453736-1	HOUSING
1	1	-	-	B	460680-2	FEED FINGER ASSY
-	1	-	-	A	22374-7	VALVE, QUICK EXHAUST
-	1	-	-	A	22304-1	NIPPLE, HEX 1/8 NPT
1	1	-	-	A	690191-1	PLUG, NYLON
1	1	-	-	C	455674-1	RAM
1	1	-	-	A	690125-1	WASHER, LAMINATED
1	1	-	-	A	690124-1	WASHER, RAM
1	1	-	-	A	7-21002-9	BOLT, CRIMPER (5/16-24x1.00)
1	1	-	-	A	690223-2	SPACER, INSULATION DISC
1	1	-	-	D	354777-1	WIRE DISC, PLASTIC
1	1	-	-	A	22480-5	WASHER, SPRING
1	1	-	-	B	690212-1	POST, RAM
1	1	-	-	A	462505-1	STRIPPER
1	1	-	-	D	455676-1	PLATE, BASE
2	2	-	-	A	22354-8	DRAG, STUD
1	1	-	-	B	455678-1	PLATE, STRIP GUIDE
1	1	-	-	C	240825-2	PLATE, STRIP HOLD DOWN
2	2	-	-	A	4-22281-1	SPRING, DRAG
1	1	-	-	A	454177-1	DRAG, STOCK
2	2	-	-	C	454204-5	GUIDE, STRIP (FRONT)
1	1	-	-	C	690481-7	SPACER, HOLD DOWN
1	1	-	-	A	23846-1	SPRING, HOLD DOWN
1	1	-	-	B	240644-1	PLATE, REAR SHEAR
2	2	-	-	C	1-240645-5	SPACER, SHEAR PLATE
1	1	-	-	B	240642-4	PLATE, FRONT SHEAR
1	1	-	-	D	1-240654-2	ANVIL
1	1	-	-	B	5-240651-3	BLADE, SLUG
1	1	-	-	D	455892-5	HOLD DOWN, TERMINAL
1	1	-	-	C	3-240641-0	SPACER, SLUG BLADE
1	1	-	-	C	3-456406-3	CRIMPER, WIRE

THIS DRAWING IS A CONTROLLED DOCUMENT.

THIS DRAWING IS UNCLASSIFIED - RELEASED FOR PUBLICATION - OCT. 1999 - BY AMP INCORPORATED. ALL RIGHTS RESERVED.

LOC A  
DIST 66

- ① RECOMMENDED SPARE PARTS.
- ② GREASE LIGHTLY.
- ③ GUARD MUST BE IN PLACE WHEN OPERATING APPLICATOR IN A BENCH MACHINE.
- ④ SEE DRAWING FOR COMPONENTS
- ⑤ ITEM 78 IS USED ON BENCH MODEL G ONLY.

QTY	REV	U/M	DWG SIZE	PART NO	DESCRIPTION	ITEM NO
2	2	-	-	C	3-354779-0	PIN, WIRE DISC (.3140)C
2	2	-	-	C	2-354779-2	PIN, WIRE DISC (.3100)B
2	2	-	-	C	1-354779-4	PIN, WIRE DISC (.3060)A
1	1	-	-	A	986950-1	WASHER, FLAT PRECISION
						125
						124
						123
						122
						121
						120
						119
						118
						117
						116
						115
						114
2	2	-	-	A	21024-5	WASHER, LOCK (#10) AIR ASSY
						113
						112
						111
7	7	-	-	A	21024-4	WASHER, LOCK (NO.8) SHEAR BL
						110
						109
2	2	-	-	A	21018-4	NUT, HEX (4-40) DRAG
						108
						107
						106
2	2	-	-	A	21022-2	NUT, HEX SL (8-32) DRAG STUD
						105
						104
						103
2	2	-	-	A	2-21006-6	SCR, SKT SET (4-40x.62) DRAG
						102
1	1	-	-	A	21009-2	SCR, SKT SET (1/4-20x.25) RAM
						101
2	2	-	-	A	21017-2	SCR, DRIVE (#2x.19) ID PLATE
						100
						99
1	1	-	-	B	461264-1	PLATE, IDENTIFICATION
						98
						97
						96
2	2	-	-	A	2-21002-2	SCR, BHC (8-32x.50) STRIPPER
						95
4	4	-	-	A	2-21002-9	SCR, BHC (10-32x.75) CAP
						94
1	1	-	-	A	22733-8	SCR, BHC (8-32x.38 LW) ANVIL
						93
4	4	-	-	A	3-21002-3	SCR, BHC (1/4-20x.50) ST 6D PL
						92
3	3	-	-	A	2-22733-8	SCR, BHC (1/4-20x.62) H5G
						91
						90
						89
						88
2	2	-	-	A	2-21000-7	SCR, 5HC (8-32x.50) SLUG BLADE
						87
3	3	-	-	A	2-21000-6	SCR, 5HC (8-32x.38) STRIP GUIDE
						86
2	2	-	-	A	2-21000-9	SCR, 5HC (8-32x.75) R STRIP GUIDE
						85
						84
						83
						82
						81
2	2	-	-	A	3-21002-0	SCR, BHC (10-32x.88) SHEAR PL
						80
1	-	-	-	A	455750-8	GUARD ASSY
						79
-	REF	-	-	A	679532-1	INSERT, GUARD
						78
						77
						76
						75
						74
						73
						72
						71

QTY	REV	U/M	DWG SIZE	PART NO	DESCRIPTION	ITEM NO
-2	-1	-	-			

QTY RECD PER ASSY		PARTS LIST	

QTY	REV	U/M	DWG SIZE	PART NO	DESCRIPTION	ITEM NO
-2	-1	-	-			

QTY RECD PER ASSY		PARTS LIST	