

## **TLC5942EVM-248**

This user's guide describes the characteristics, setup, and use of the TLC5942EVM-248 evaluation module (EVM). This EVM demonstrates the Texas Instruments TLC5942, 16-channel, constant-current LED driver. Included are setup instructions, a schematic diagram, a bill of materials, and printed-circuit board layout drawings for the evaluation module.

### **Contents**

1	Introduction .....	2
	1.1 Requirements .....	2
	1.2 Related Documentation From Texas Instruments .....	3
	1.3 If You Need Assistance .....	3
2	Setup .....	3
	2.1 Input/Output Connector Descriptions.....	3
	2.2 Software Setup.....	4
	2.3 Hardware Setup.....	5
3	Operation .....	5
	3.1 Running the Software .....	5
	3.2 Software Features .....	6
4	Board Layout.....	12
	4.1 Layout.....	12
5	Schematic and Bill of Materials.....	19
	5.1 Schematic .....	19
	5.2 Bill of Materials .....	20

### **List of Figures**

1	TLC5942 EVM Software Startup Screen .....	6
2	Advanced Options .....	8
3	White and Black Frames .....	10
4	Advanced Window for White and Black Frames. ....	11
5	Displayed White and Black Frames.....	11
6	Assembly Layer.....	12
7	Top Layer.....	13
8	Layer 2.....	14
9	Layer 3.....	15
10	Bottom Layer.....	16
11	Assembly Layer .....	17
12	Top Layer .....	18
13	Bottom Layer .....	19

### **List of Tables**

1	HPA248A Bill of Materials.....	20
2	HPA249A Bill of Materials.....	21

## 1 Introduction

The Texas Instruments TLC5942 is a 16-channel, constant-current LED driver that can drive up to 50 mA per channel. The integrated circuit (IC) contains two separate input buses: one for 7-bit dot correction and one for 12-bit PWM dimming. The dot correction circuitry independently adjusts the dc current for each output channel to compensate for brightness differences between LEDs. Dot correction information is written into the TLC5942 internal registers. The 12-bit PWM dimming turns each output on and off within each frame refresh period. PWM dimming information is written into the TLC5942 internal registers. For more information on dot correction and PWM dimming, see the TLC5942 data sheet ([SBVS096](#)), a dot correction technical paper ([SLYT225](#)), and a PWM dimming technical paper ([SLYT238](#)) on the TI Web site. This EVM contains three TLC5942 ICs connected in series. The three ICs drive 16 light-emitting diodes (LEDs), each having a red, green, and blue LED in the same package.

### 1.1 Requirements

In order to operate this EVM, the following components must be connected and properly configured. All components, software, and connectors are supplied in the EVM except for the host computer and the DC power supply

#### 1.1.1 Software

Texas Instruments provides a compact disk (CD) in the EVM kit that contains the software necessary to evaluate the TLC5942. Check the TLC5942 product folder on the TI Web site ([www.ti.com](http://www.ti.com)) for updates to the software.

#### 1.1.2 Host Computer

A personal computer (PC) with a USB port is required to operate this EVM. The TLC5942 software runs on the PC and communicates with the EVM via the PC's USB port.

PC Requirements

- Windows™ 2000 or Windows™ XP operating system
- USB port
- Minimum of 30 MB of free hard disk space (100 MB recommended)
- Minimum of 256 MB of RAM

#### 1.1.3 Power Supply Requirements

A dc power supply capable of delivering 5 V at 1 A is required to power the EVM.

#### 1.1.4 Printed-Circuit Board Assemblies

The TLC5942EVM-248 EVM kit contains two printed-circuit boards (PCB): HPA248 (driver board) and HPA249 (LED board). The HPA248 PCB contains the TLC5942 ICs and their required external components. This board contains several jumpers and connectors that enable you to customize the board for specific operating conditions. The HPA249 contains 16 LEDs, each with three individual LED junctions in the same package: a red, a green, and a blue junction. The orderable part number for this PCB is RGBLEDEVM-249. Users can use the driver board to power the supplied LED board or to power their own custom LED board.

#### 1.1.5 USB-TO-GPIO Interface Board

The USB-TO-GPIO Interface Adapter (<http://focus.ti.com/docs/toolsw/folders/print/usb-to-gpio.html>) is the link that allows the PC and the EVM to communicate. One end of the USB-TO-GPIO box connects to the PC with the supplied USB cable, and the other end connects to the TLC5942 driver board. When the user programs the EVM from the PC, the PC communicates with the USB-TO-GPIO via the USB interface. The USB-TO-GPIO converts the USB signal to a format that the EVM can use.

---

## 1.2 Related Documentation From Texas Instruments

1. *TLC5942, 16-Channel, 12-Bit PWM LED Driver With 7-Bit Dot Correction* data sheet ([SBVS096](#))
2. *TPC5940 Dot Correction Compensates for Variations in LED Brightness* technical paper ([SLYT225](#))
3. *TLC5940 PWM Dimming Provides Superior Color Quality in LED Video Displays* technical paper ([SLYT238](#))

## 1.3 If You Need Assistance

Contact your local TI sales representative.

## 2 Setup

This section describes the jumpers and connectors on the EVM as well as how to properly connect, set up, and use the TLC5942EVM-248.

### 2.1 Input/Output Connector Descriptions

#### 2.1.1 J1 – Communications Input Connector

This connects to the USB-TO-GPIO interface box with the supplied 10-pin ribbon cable.

#### 2.1.2 J2 – LED Connector

This connector mates to the HPA249 LED board. The customer can also connect a custom board to this connector with a 30-pin ribbon cable. To minimize stray inductance and ringing on the output traces, make connections to this connector as short as possible.

#### 2.1.3 J3 – LED Connector

This connector mates to the HPA249 LED board. The customer can also connect a custom board to this connector with a 30-pin ribbon cable. To minimize stray inductance and ringing on the output traces, make connections to this connector as short as possible.

#### 2.1.4 J4 – JTAG Connector

This connector can be used for JTAG communications to help debug user-generated software. This connector is not used with the standard EVM configuration.

#### 2.1.5 J5 – Microprocessor RESET

Leave open. Short J5-1 and J5-2 together to manually reset the TMS320VC5509 microprocessor on the EVM.

#### 2.1.6 J6 –VLED

This is the positive input supply to the EVM. The input voltage should be between 5 V and 17 V. To minimize power dissipation, ensure that the input voltage is as low as possible. Twist the leads to the input supply, and keep them as short as possible to minimize EMI transmission.

#### 2.1.7 J7 –GND Connector

This is the return for the input supply to the EVM. Twist the leads to the input supply, and keep them as short as possible to minimize EMI transmission.

### 2.1.8 JP1 –Communications

This jumper connects the onboard TMS320VC5509 DSP to the TLC5942 LED drivers. This jumper comes preconfigured to connect the DSP control signals to the LED driver ICs. The GND pins on this jumper do not need shorting shunts because these pins are already grounded on the PCB. The user can remove all shorting shunts and connect their microprocessor control signals to this jumper to program the LED drivers.

**CAUTION**

Do not drive the outputs of the TMS320VC5509 DSP with external control signals.

### 2.1.9 JP2 – RED LED

This jumper must be shorted to connect the red LED driver's OUT15 pin to the red LED. This jumper can be opened to measure the current flowing into the OUT15 pin from the red LED.

### 2.1.10 JP3 –Green LED

This jumper must be shorted to connect the green LED driver's OUT15 pin to the green LED. This jumper can be opened to measure the current flowing into the OUT15 pin from the green LED.

### 2.1.11 JP4 – BLUE LED

This jumper must be shorted to connect the blue LED driver's OUT15 pin to the blue LED. This jumper can be opened to measure the current flowing into the OUT15 pin from the blue LED.

## 2.2 Software Setup

If installing from a CD, insert the CD and run Setup.exe. Follow all the prompts to allow the software to be installed.

If installing from the TI Web site, go to [www.ti.com](http://www.ti.com)

---

**Note:** This installation page is best viewed with Microsoft™ Internet Explorer™ browser (It may not work correctly with other browsers)

---

Click on the install button; your PC gives you a security warning and asks if you want to install this application. Select Install to proceed.

With both types of installation, the software attempts to install the Microsoft Dot Net Framework 2.0 (if it is not already installed). This framework is required for the software to run.

After installation, the software should automatically run.

During future use of the software, it may prompt you to install a new version if it becomes available on the TI Web site.

---

**Note:** VeriSign™ code signing is used to prevent any malicious code from changing this application. If at any time in the future the binaries are modified, the code will no longer attempt to run.

---

## 2.3 Hardware Setup

Ensure that the shorting shunts are installed on JP1, JP2, JP3, and JP4.

Connect the LED board (HPA249) to the LED driver board (HPA248).

Connect the USB-TO-GPIO interface board to the host computer using the supplied USB cable. Connect the TLC5942EVM board to the USB-TO-GPIO interface board using the supplied 10-pin ribbon cable. The connectors on the ribbon cable are keyed to prevent incorrect installation.

Quick Connection Diagram USB Interface Adapter

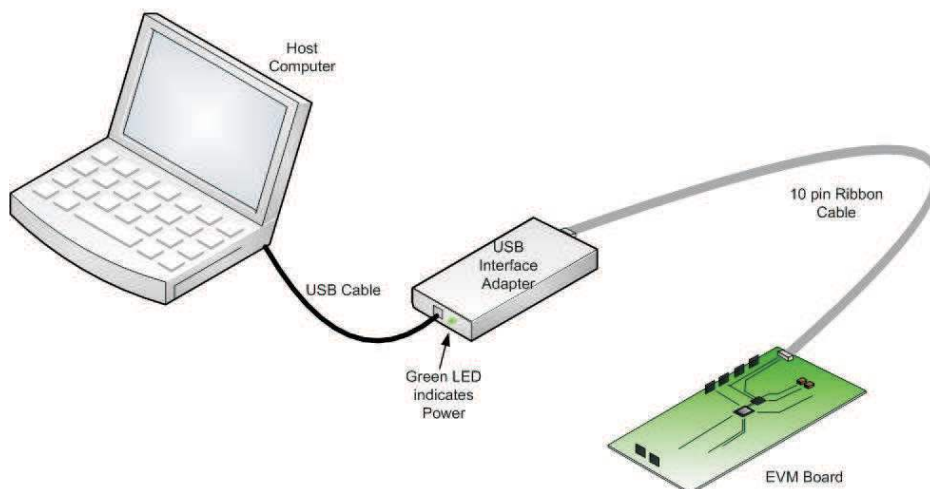

Connect an input voltage supply to the TLC5942EVM board. The TLC5942 uses an input voltage between 5 V and 17 V. Connect the positive input voltage to VLED on the LED driver board (J6), and connect the input voltage return (ground) connection to GND (J7).

### CAUTION

Hot plugging the input supply with long leads can generate transients on the input supply bus that exceed the maximum ratings of the EVM. Connect the input supply before it is turned on.

Turn on the input supply voltage.

## 3 Operation

This section provides instructions on how to turn on the TLC5942EVM and operate the software.

The user can now run the host computer software and change the LED programming with the easy-to-use graphical interface.

### 3.1 Running the Software

Click on the icon on the host computer to start the software. If the host computer has no icon, then use the *start* button in the lower left corner of the screen to browse the program folders to find the software. Once started, the software checks the firmware in the USB-TO-GPIO interface box to ensure that it is compatible with the software. If the firmware is not compatible, the software gives the user instructions on how to reprogram it. Once the software is started and the communication channel is connected, the user can now use the graphical interface to program the LEDs. If the EVM is properly connected, the software screen looks like [Figure 1](#) when first opened.

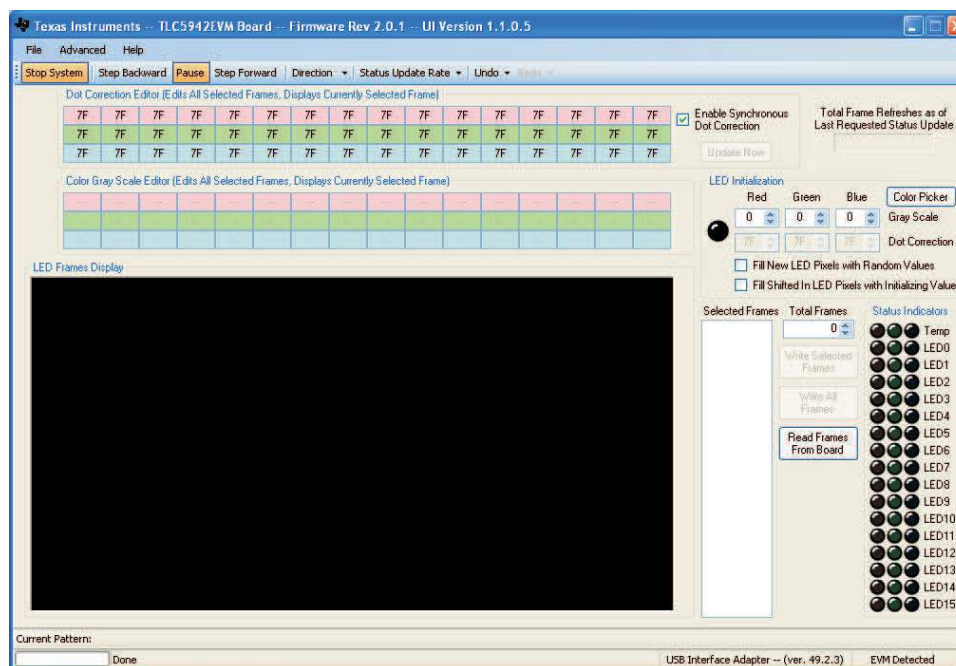

Figure 1. TLC5942 EVM Software Startup Screen

## 3.2 Software Features

### 3.2.1 Dot Correction Editor

This window displays the dot correction values of the frame that is currently selected in the *LED Frames Display*. The user can change the dot correction value between 00h and 7Fh.

The “Enable Synchronous Dot Correction” check box determines how often the dot correction values are updated. When this box is checked, each LED frame’s dot correction is updated at the beginning of its frame. When this box is not checked, all frames are initially displayed with frame 0’s dot correction. No additional dot correction values are programmed into the EVM. If the box is toggled from checked to unchecked, the LEDs are displayed with the last programmed dot correction values. When the box is unchecked, the dot correction values are not automatically updated. The user can change and then update dot correction values at any time by modifying the dot correction values in the Dot Correction Editor and clicking on the *Update Now* button.

### 3.2.2 Color Grayscale Editor

This window displays the PWM grayscale values of the frame that is currently selected in the *LED Frames Display*. The user can change the PWM grayscale to any value between 000h and FFFh.

### 3.2.3 LED Frames Display Window

This window displays the different *frames* to be programmed into the LED drivers. Add or remove frames from this window by increasing or decreasing the *Total Frames* counter just to the right of this window. Selecting and then right-clicking on any frame in this window brings up many useful options for manipulating the LED frames.

### 3.2.4 LED Initialization Window

This window allows the user to select the color (via the PWM grayscale and dot correction) of the LEDs that are added to the LED Frame Display Window. This window has several options. Clicking on the *Color Picker* button brings up a window that allows the user to select preset or custom colors. Note that the colors available in Windows™ have a 10-bit resolution whereas the TLC5942 is capable of 12-bit resolution. The TLC5942 software automatically converts the chosen color to the 12-bit resolution scale.

If the *Fill New LED Pixels with Random Values* button is not checked, the chosen LED color is shifted into the *Display Frames Window* when the *Total Frames* counter is increased. If this button is checked, the new LED frame contains random values. Note that the LED colors displayed in this window are only approximate to the actual LED color on the EVM.

### 3.2.5 Total Frames

This window allows the user to increase or decrease the number of frames in the LED Frames Display window. Frames are always added to and removed from the bottom of the LED Frames Display window.

### 3.2.6 Write Selected Frames

This button writes the PWM grayscale and dot correction values of the selected frame to the EVM.

### 3.2.7 Write All Frames

This button writes the PWM grayscale and dot correction values of every frame in the LED Frames Display window.

### 3.2.8 Read All Frames

This button reads the PWM grayscale and dot correction values from the EVM and displays them in the LED Frames Display window. All contents in the window are erased and then replaced with the frames that are read from the EVM.

### 3.2.9 Status Indicator Window

This window displays the TLC5942 LOD and overtemperature functions. It shows the status of each LED. The onboard DSP reads the GSOUT pin from U8 on the EVM and decodes the data. If all LEDs are properly connected, all indicators are turned off. If an LED becomes open during operation, its respective indicator light turns on. The *Status Update Rate* pulldown menu just above the *Dot Correction Editor* window allows the user to select the refresh rate of the Status Indicators.

### 3.2.10 Advanced Tab

This Advanced Tab contains several submenus.

*Reset the Board* resets the onboard DSP, causing the EVM to display the preprogrammed default frame sequence.

*Write Firmware to EEPROM* allows the user to manually rewrite the firmware to the onboard EEPROM in the event it becomes corrupted.

*Enable Tool Tips* enables and disables the popup dialog boxes that appear when you run your mouse over some of the software options.

*Advanced Options...* opens the window shown in [Figure 2](#).

*Run Test Pattern* loads a default test mode pattern used during assembly. It cycles through the red, green, and then blue LEDs.

*Copy as Comma-Separated Format* When checked, a frame copied from the LED Frames Display can be pasted into a document in the Comma-Separated Format. When not checked, a frame copied from the LED Frames Display can be pasted into a document in the standard text format.

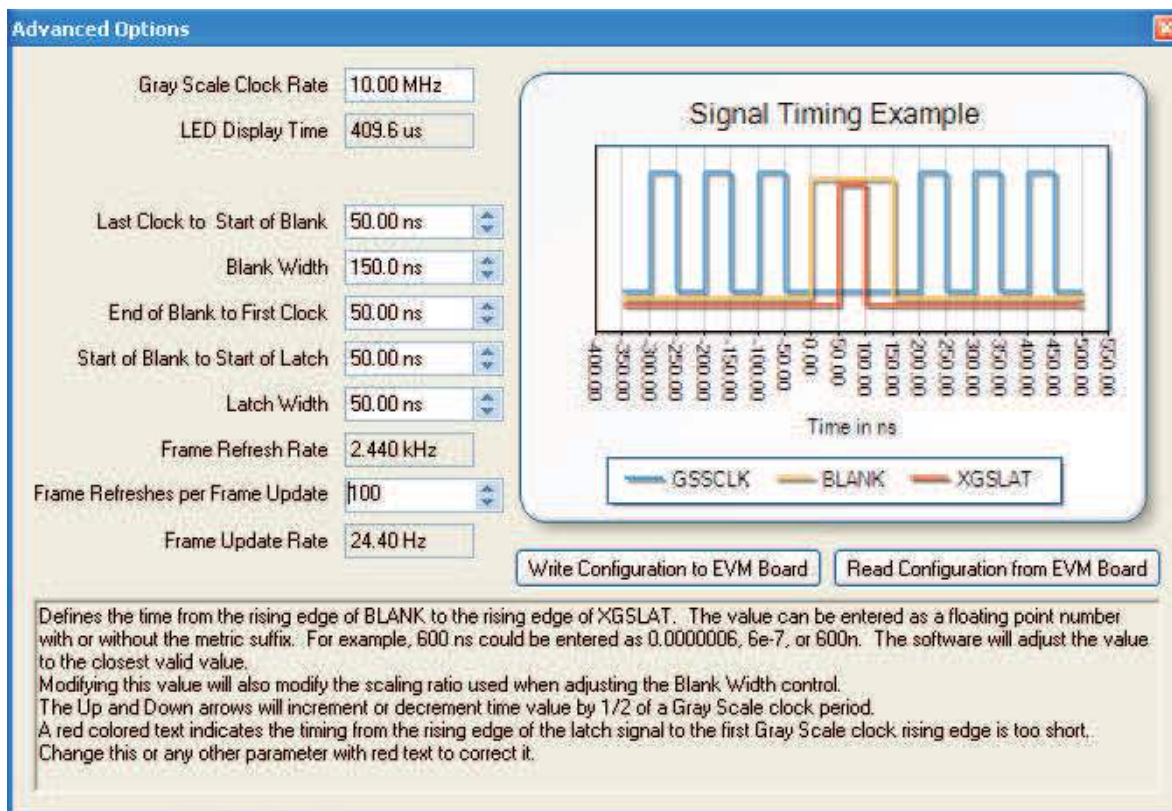

**Figure 2. Advanced Options**

The options in this window allow the user to modify the timing parameters of the signals written to the TLC5942 ICs. All options are explained in the lower portion of the window. Note that all times and frequencies are approximate.

### 3.2.11 System Controls

The system control tool bar, located just above the Dot Correction Editor, allows the user to start and stop the system, pause and play frames, change the direction of the frames being played, and modify the time delay between updates to the Status Indicators.

### 3.2.12 File – Save and Load

This tab allows the user to save and load custom frames. An example of the file format follows.

#### 3.2.12.1 Text File

The LED Frames Display data can be saved as a standard text file. The header in the text file should be `// TLC59xx Frame Data`. The frame information is broken up into pixels, with each pixel being broken up into a red, green, and blue LED. Each LED's information consists of its PWM value in hexadecimal and its dot correction value in hexadecimal. In the following sample text file, Frame 0 is a white pixel that is generated by programming each color of each LED with a PWM value of FFFh and a dot correction value of 7Fh. Frame 1 is a red pixel at half brightness that is generated by programming the red LEDs to their full PWM value of FFFh and to half of their dot correction value, 40h.



```

*****
// TLC59xx Frame Data

{
Pixel 0 { Red { FFF, 7F } Green { FFF, 7F } Blue { FFF, 7F } }
Pixel 1 { Red { FFF, 7F } Green { FFF, 7F } Blue { FFF, 7F } }
Pixel 2 { Red { FFF, 7F } Green { FFF, 7F } Blue { FFF, 7F } }
Pixel 3 { Red { FFF, 7F } Green { FFF, 7F } Blue { FFF, 7F } }
Pixel 4 { Red { FFF, 7F } Green { FFF, 7F } Blue { FFF, 7F } }
Pixel 5 { Red { FFF, 7F } Green { FFF, 7F } Blue { FFF, 7F } }
Pixel 6 { Red { FFF, 7F } Green { FFF, 7F } Blue { FFF, 7F } }
Pixel 7 { Red { FFF, 7F } Green { FFF, 7F } Blue { FFF, 7F } }
Pixel 8 { Red { FFF, 7F } Green { FFF, 7F } Blue { FFF, 7F } }
Pixel 9 { Red { FFF, 7F } Green { FFF, 7F } Blue { FFF, 7F } }
Pixel 10 { Red { FFF, 7F } Green { FFF, 7F } Blue { FFF, 7F } }
Pixel 11 { Red { FFF, 7F } Green { FFF, 7F } Blue { FFF, 7F } }
Pixel 12 { Red { FFF, 7F } Green { FFF, 7F } Blue { FFF, 7F } }
Pixel 13 { Red { FFF, 7F } Green { FFF, 7F } Blue { FFF, 7F } }
Pixel 14 { Red { FFF, 7F } Green { FFF, 7F } Blue { FFF, 7F } }
Pixel 15 { Red { FFF, 7F } Green { FFF, 7F } Blue { FFF, 7F } }
}

Frame 1
{
Pixel 0 { Red { FFF, 40 } Green { 000, 00 } Blue { 000, 00 } }
Pixel 1 { Red { FFF, 40 } Green { 000, 00 } Blue { 000, 00 } }
Pixel 2 { Red { FFF, 40 } Green { 000, 00 } Blue { 000, 00 } }
Pixel 3 { Red { FFF, 40 } Green { 000, 00 } Blue { 000, 00 } }
Pixel 4 { Red { FFF, 40 } Green { 000, 00 } Blue { 000, 00 } }
Pixel 5 { Red { FFF, 40 } Green { 000, 00 } Blue { 000, 00 } }
Pixel 6 { Red { FFF, 40 } Green { 000, 00 } Blue { 000, 00 } }
Pixel 7 { Red { FFF, 40 } Green { 000, 00 } Blue { 000, 00 } }
Pixel 8 { Red { FFF, 40 } Green { 000, 00 } Blue { 000, 00 } }
Pixel 9 { Red { FFF, 40 } Green { 000, 00 } Blue { 000, 00 } }
Pixel 10 { Red { FFF, 40 } Green { 000, 00 } Blue { 000, 00 } }
Pixel 11 { Red { FFF, 40 } Green { 000, 00 } Blue { 000, 00 } }
Pixel 12 { Red { FFF, 40 } Green { 000, 00 } Blue { 000, 00 } }
Pixel 13 { Red { FFF, 40 } Green { 000, 00 } Blue { 000, 00 } }
Pixel 14 { Red { FFF, 40 } Green { 000, 00 } Blue { 000, 00 } }
Pixel 15 { Red { FFF, 40 } Green { 000, 00 } Blue { 000, 00 } }
}

*****

```

### 3.2.12.2 CSV File

The program incorporates a comma-separated value file in order to facilitate ease of importing data generated by Excel™ and other programs into the software. The following file shows the same two frames saved in the .CSV format. Dot correction data is entered first. Dot correction information is preceded with a *D*. The dot correction data follows the following format: red pixel 0, red pixel 1, ..., red pixel 15, green pixel 0, green pixel 1, ..., green pixel 15, blue pixel 0, blue pixel 1, ..., blue pixel 15. All frames following a dot correction entry keep that dot correction entry until a new dot correction entry is read in.

Grayscale data is preceded with a *G*. The grayscale data follows the following format: red pixel 0, red pixel 1, ..., red pixel 15, green pixel 0, green pixel 1, ..., green pixel 15, blue pixel 0, blue pixel 1, ..., blue pixel 15.

## Operation

```

*****
// TLC59xx Frame Data

#CSF
// Data in Comma Separated Format (CSF), Format = 16xRed, 16xGreen, 16xBlue

D, 7F, 7F, 7F, 7F, 7F, 7F, 7F, 7F, 7F, 7F, 7F, 7F, 7F, 7F, 7F, 7F,
7F, 7F, 7F, 7F, 7F, 7F, 7F, 7F, 7F, 7F, 7F, 7F, 7F, 7F, 7F, 7F,
7F, 7F, 7F, 7F, 7F, 7F, 7F, 7F, 7F, 7F, 7F, 7F, 7F, 7F, 7F, 7F,

G, FFF, FFF, FFF, FFF, FFF, FFF, FFF, FFF, FFF, FFF, FFF, FFF, FFF,
FFF, FFF, FFF, FFF, FFF, FFF, FFF, FFF, FFF, FFF, FFF, FFF, FFF, FFF,
FFF, FFF, FFF, FFF, FFF, FFF, FFF, FFF, FFF, FFF, FFF, FFF, FFF, FFF,
FFF, FFF, FFF, FFF, FFF, FFF, FFF, FFF

D, 40, 40, 40, 40, 40, 40, 40, 40, 40, 40, 40, 40, 40, 40, 40, 00, 00, 00,
00, 00, 00, 00, 00, 00, 00, 00, 00, 00, 00, 00, 00, 00, 00, 00, 00, 00,
00, 00, 00, 00, 00, 00, 00, 00

G, FFF, FFF, FFF, FFF, FFF, FFF, FFF, FFF, FFF, FFF, FFF, FFF, FFF,
FFF, FFF, FFF, 000, 000, 000, 000, 000, 000, 000, 000, 000, 000, 000,
000, 000, 000, 000, 000, 000, 000, 000, 000, 000, 000, 000, 000,
000, 000, 000, 000, 000, 000, 000
*****
  
```

### 3.2.13 Measured Data

#### 3.2.13.1 Refresh Rate vs Update Rate

Figure 3 through Figure 5 help illustrate the difference between the frame refresh and the frame update rate. Figure 3 shows the EVM programmed with two frames, one white and one black.

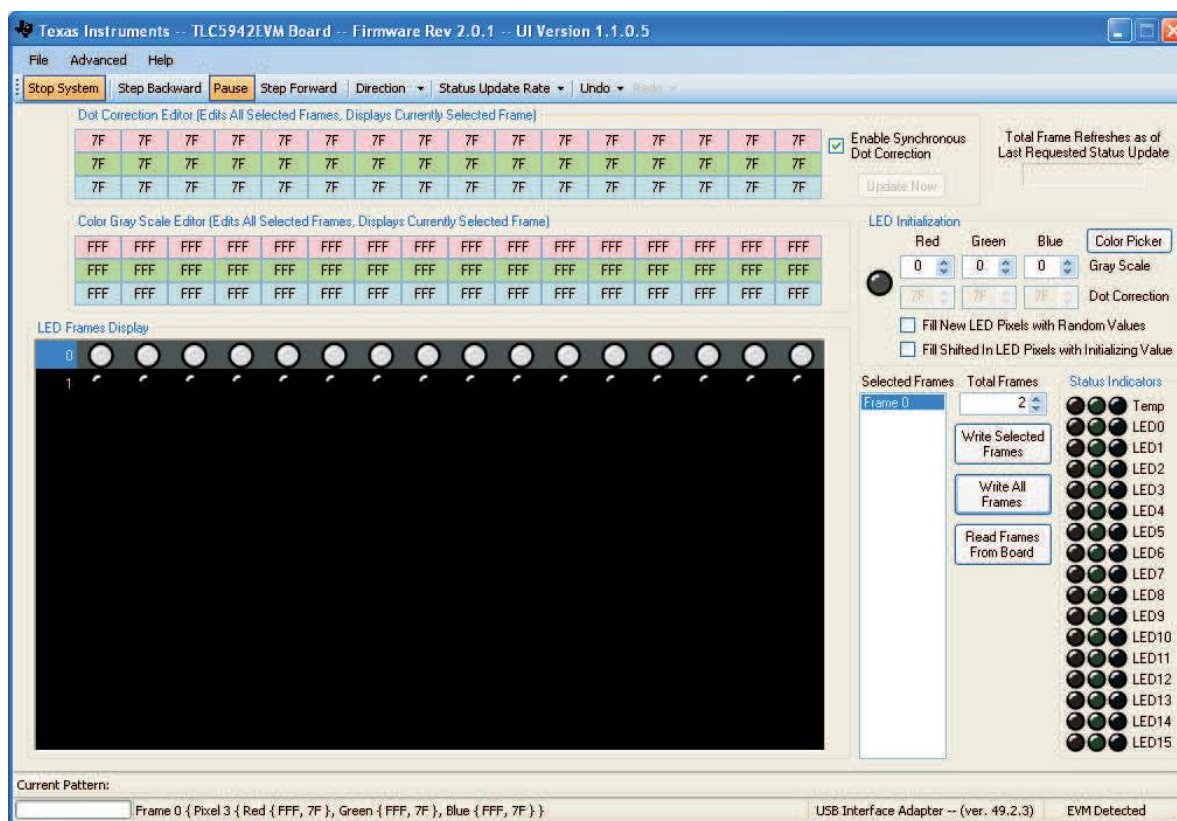
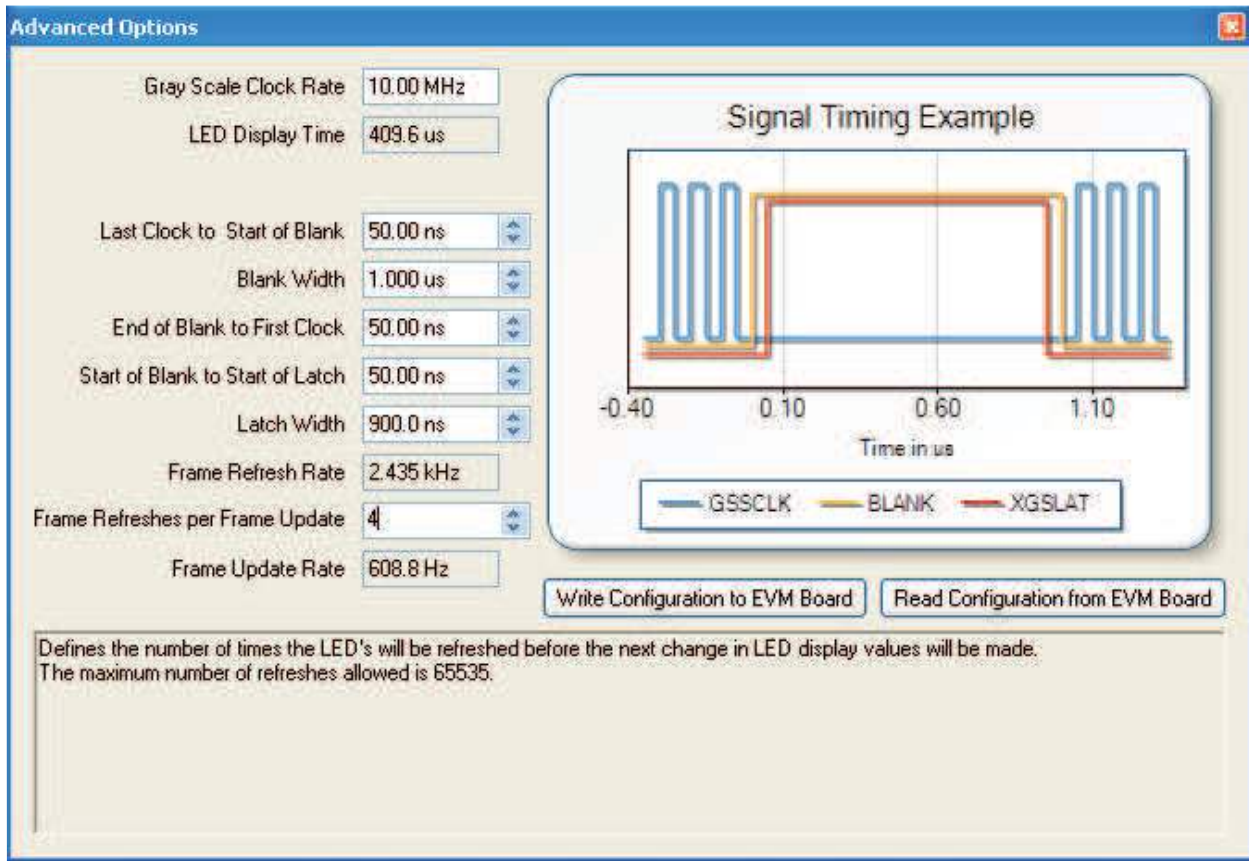

Figure 3. White and Black Frames

Figure 4 shows how the software is programmed to display these two frames



**Figure 4. Advanced Window for White and Black Frames.**

Figure 5 shows the resulting EVM waveforms. Trace 1 is the GSSIN data, trace 2 is BLANK, trace 3 is XLAT, and trace 4 is the current in an LED. When GSSIN goes high, the EVM is programming each LED with FFFh grayscale data (the white frame). This data is latched in when BLANK and XLAT both go high. Because the LED PWM grayscale register is programmed to FFFh, the LED turns on and remains on until the end of the PWM grayscale period. After the first grayscale period, BLANK goes high and then low to start another grayscale period. As programmed in the advanced window, the white frame is displayed, (or refreshed) four times. After four grayscale periods, the EVM programs and displays a black frame. The black frame is also displayed four times. As shown in both the oscilloscope plots and in the advanced window, the frame refresh rate is four times faster than the frame update rate.

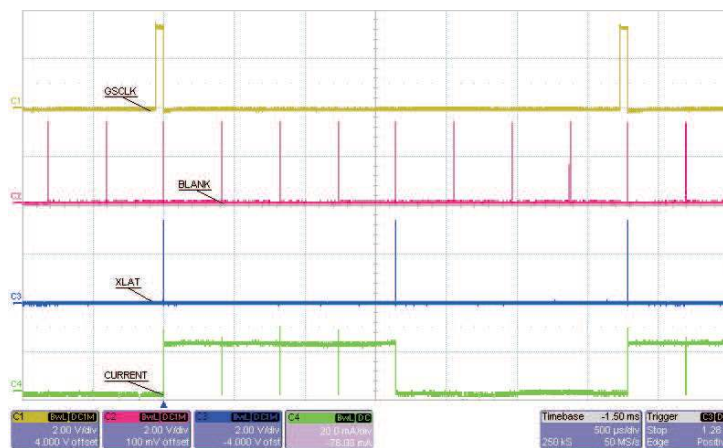

**Figure 5. Displayed White and Black Frames**

## 4 Board Layout

This section provides the TLC5942EVM-248 and RGBLEDEVM-249 board layouts and illustrations.

### 4.1 Layout

Figure 6 through Figure 10 show the board layout for the LED driver board, HPA248.

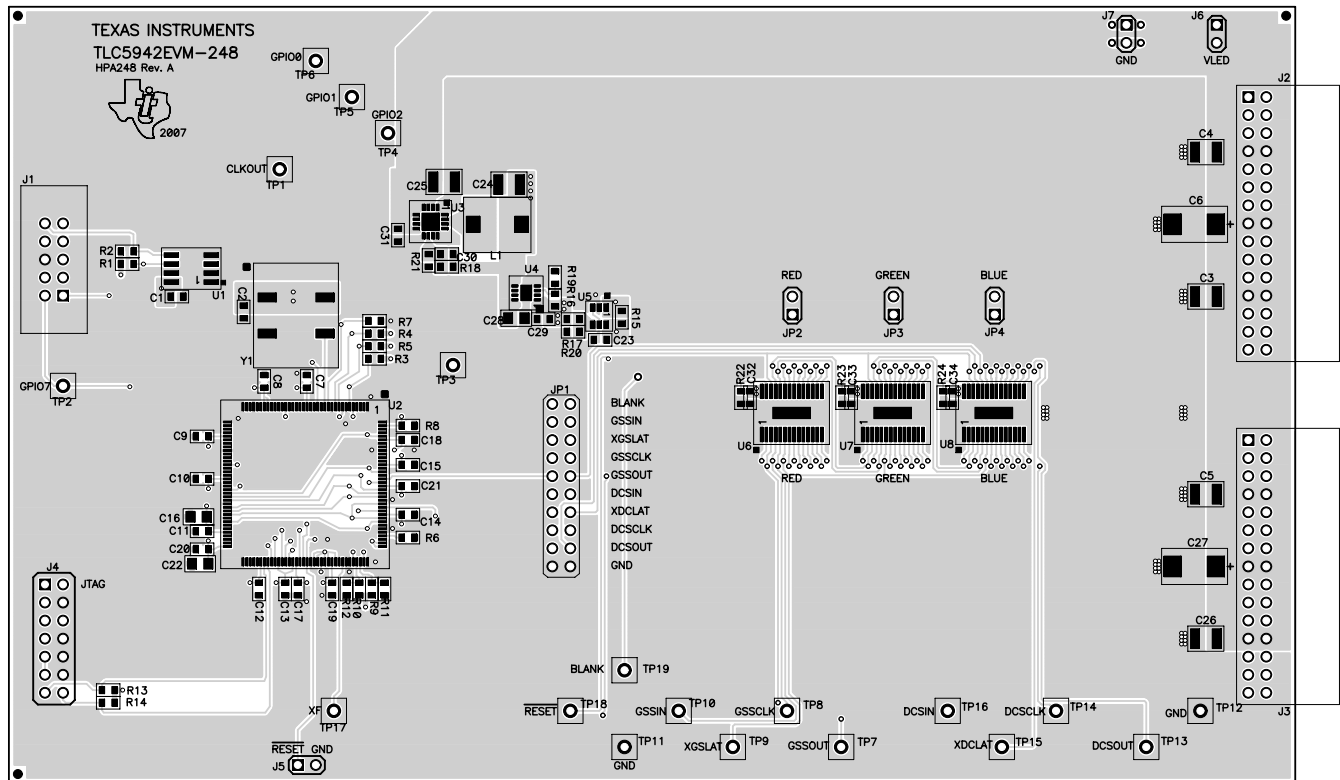
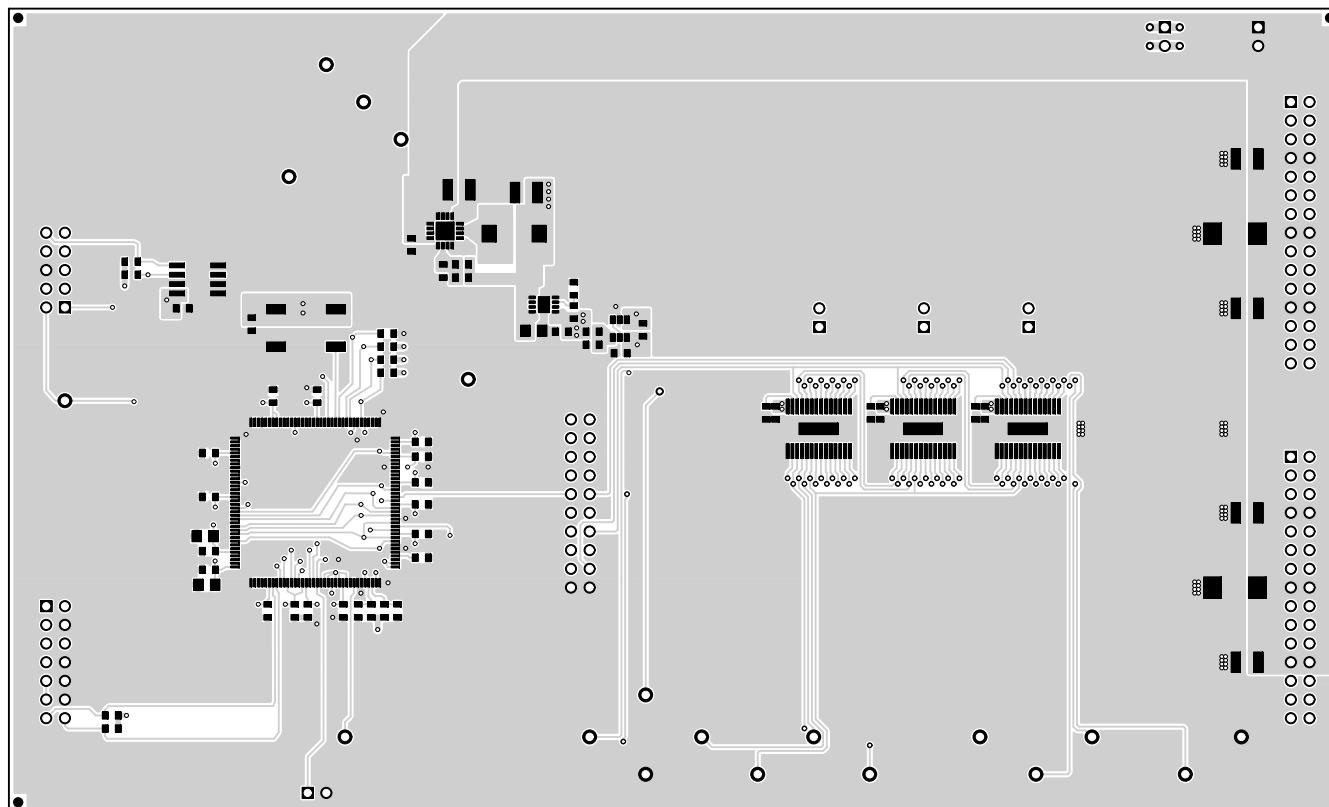
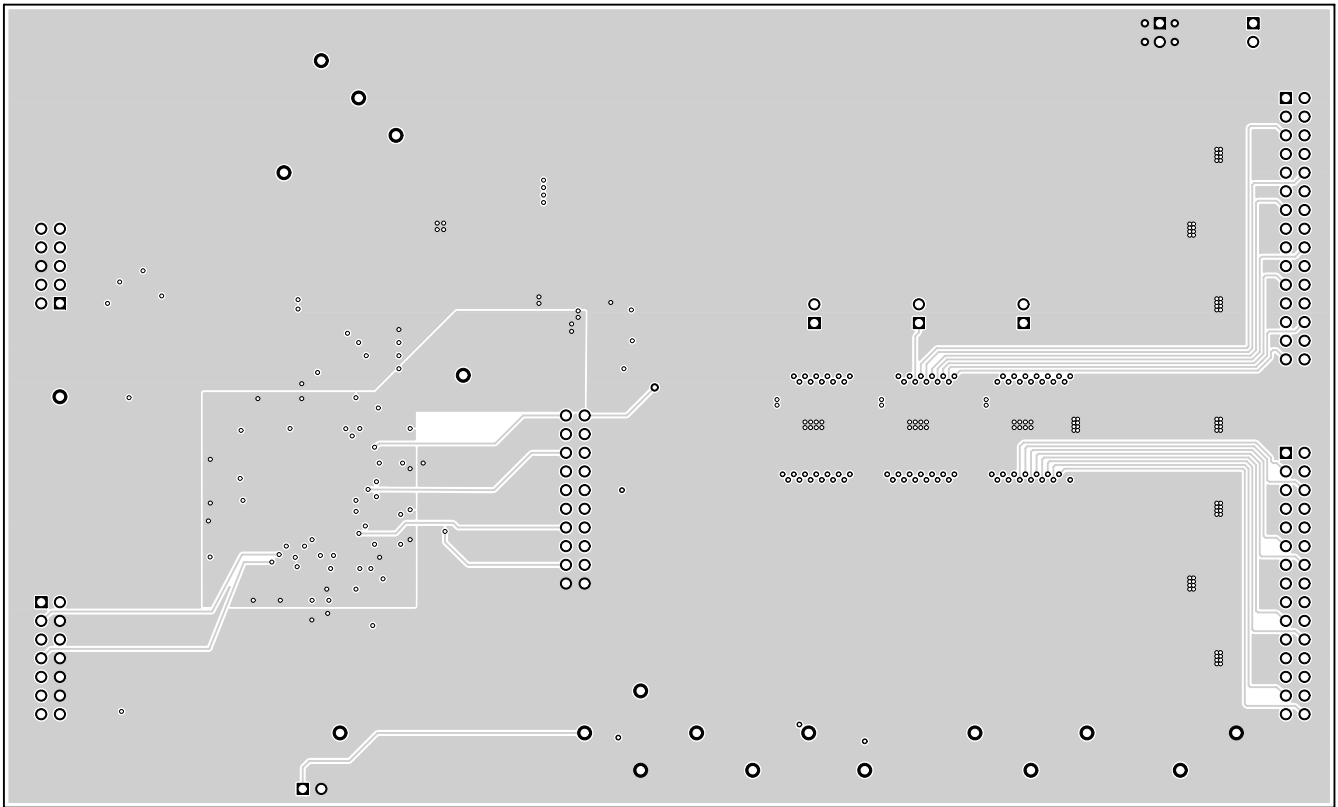

Figure 6. Assembly Layer



**Figure 7. Top Layer**



**Figure 8. Layer 2**

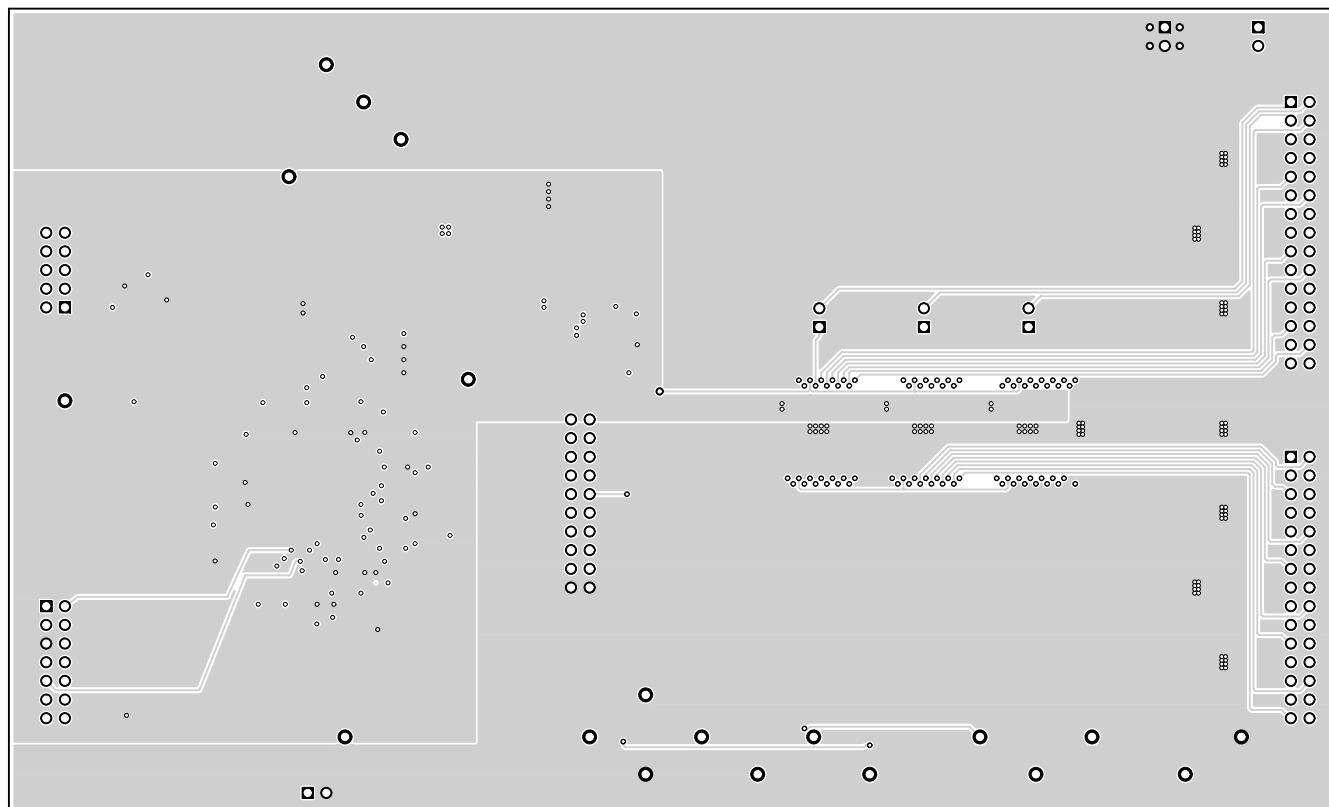
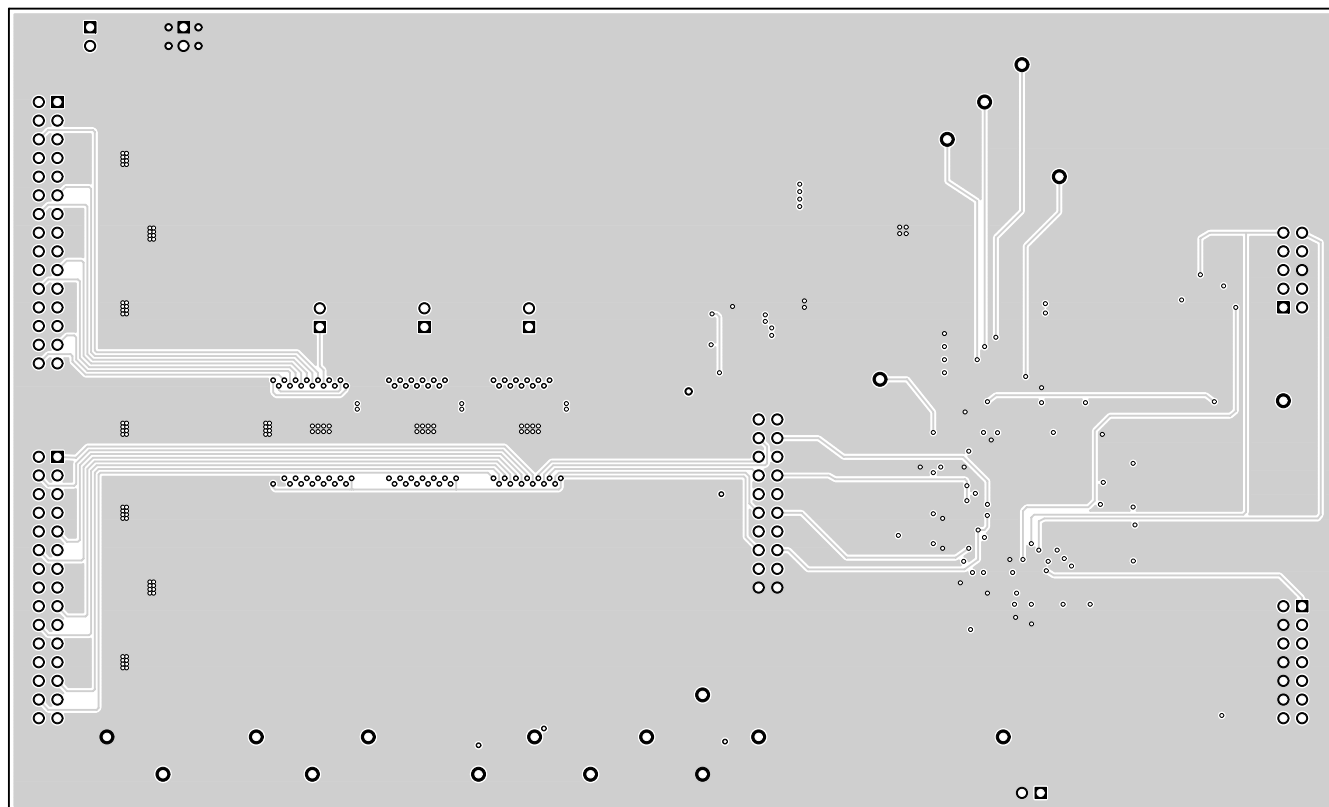

Figure 9. Layer 3



**Figure 10. Bottom Layer**

Figure 11 through Figure 13 show the board layout for the LED board, HPA249.



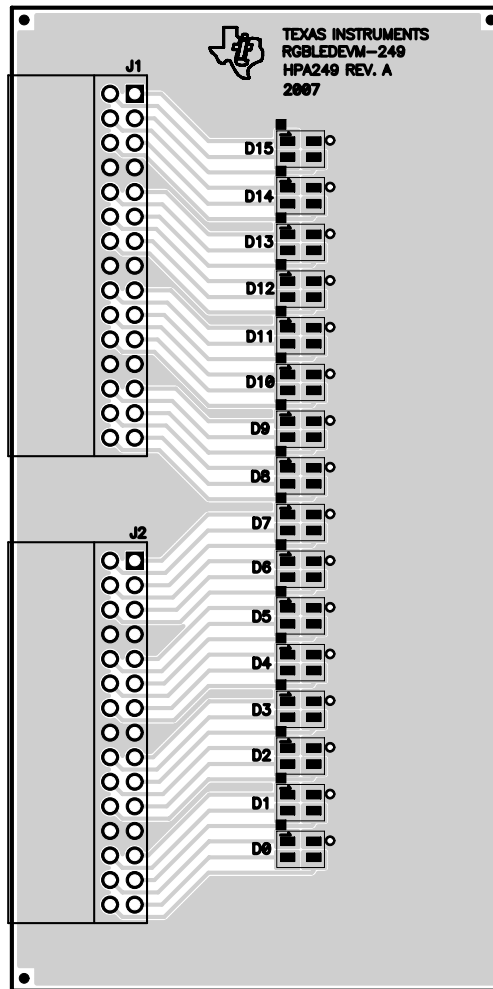

Figure 11. Assembly Layer

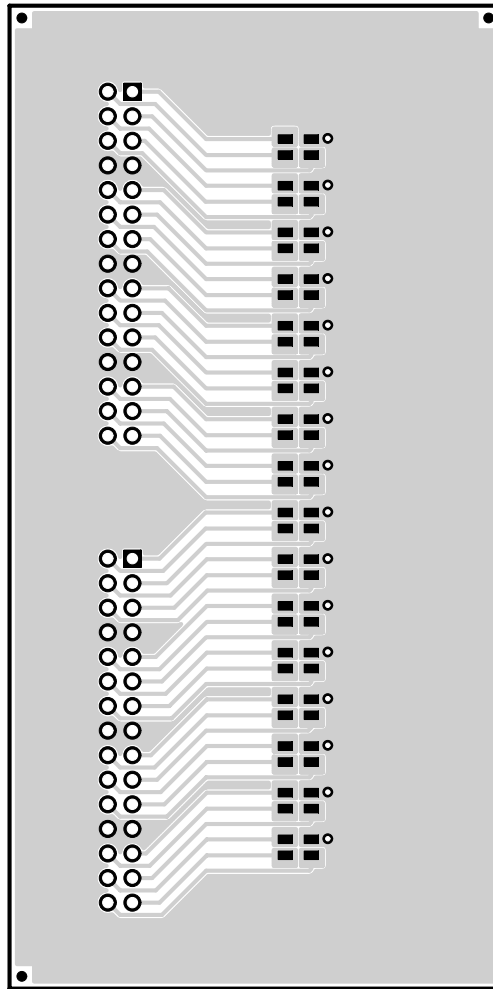

Figure 12. Top Layer

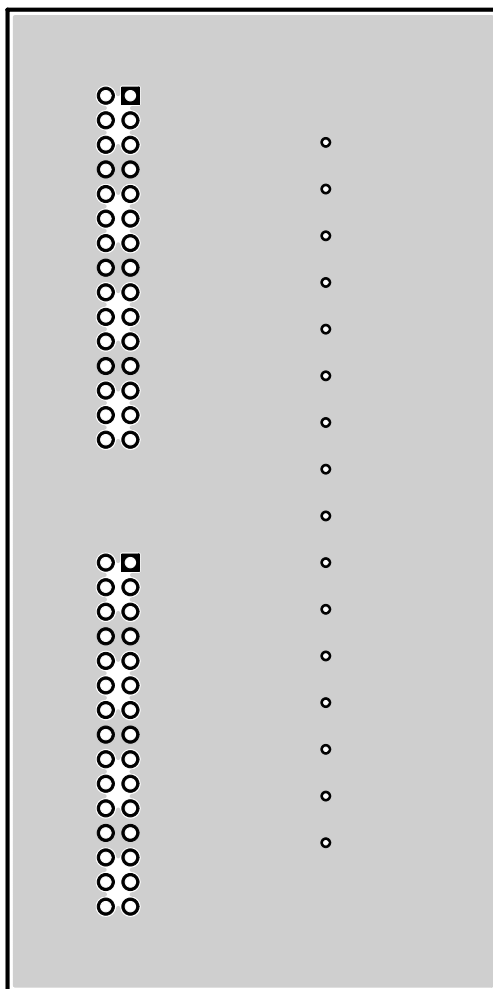

Figure 13. Bottom Layer

## 5 Schematic and Bill of Materials

This section provides the TLC5942EVM-248 and RGBLEDEVM-249 schematics and bill of materials.

### 5.1 Schematic

The schematics for the TLC5942EVM-248 and RGBLEDEVM-249 are affixed to this page.

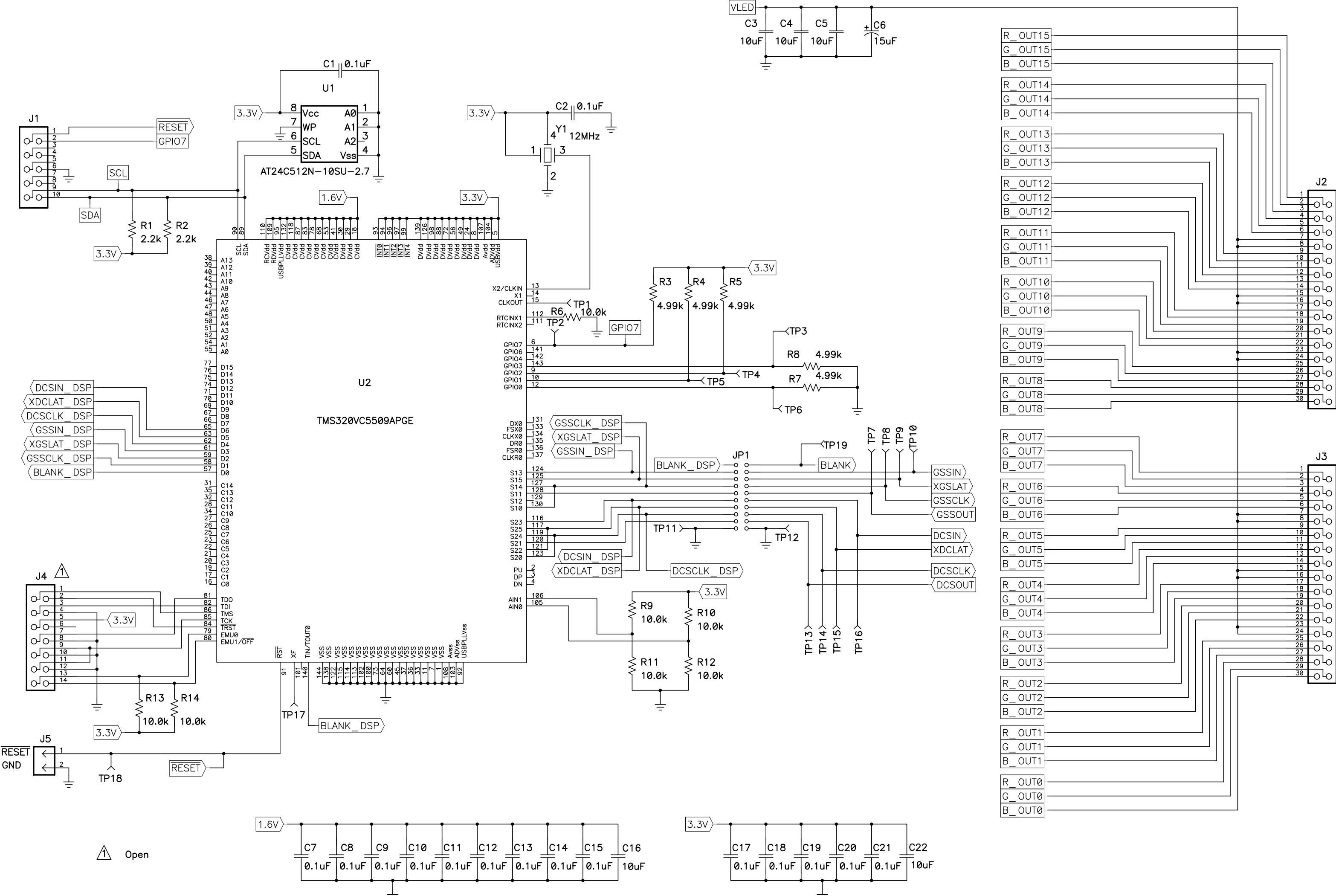

⚠ Open

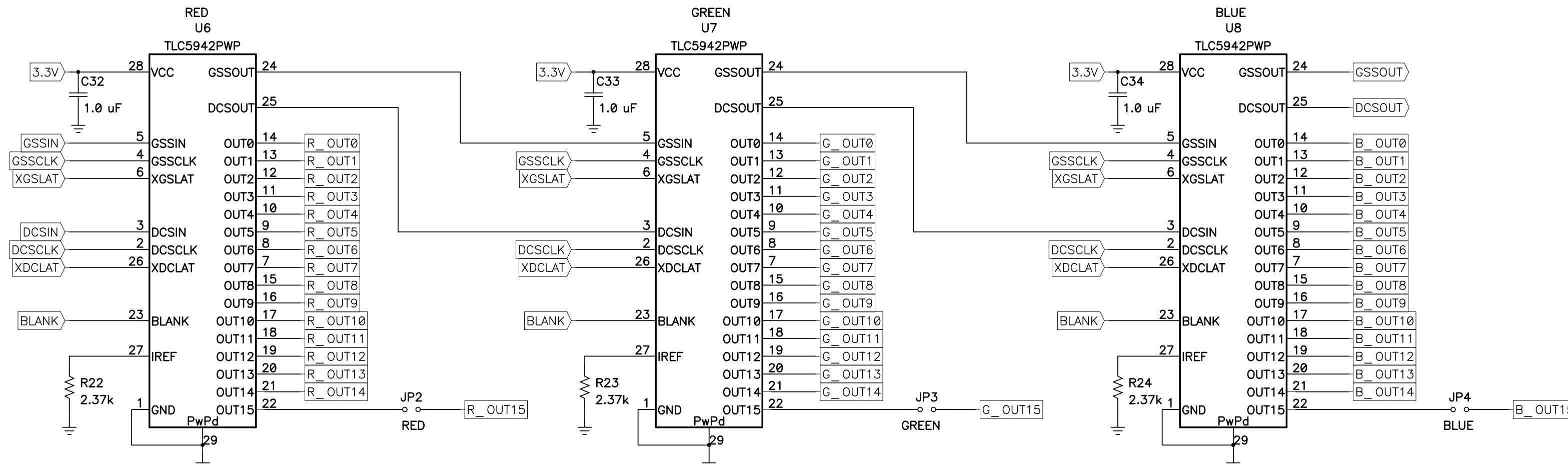
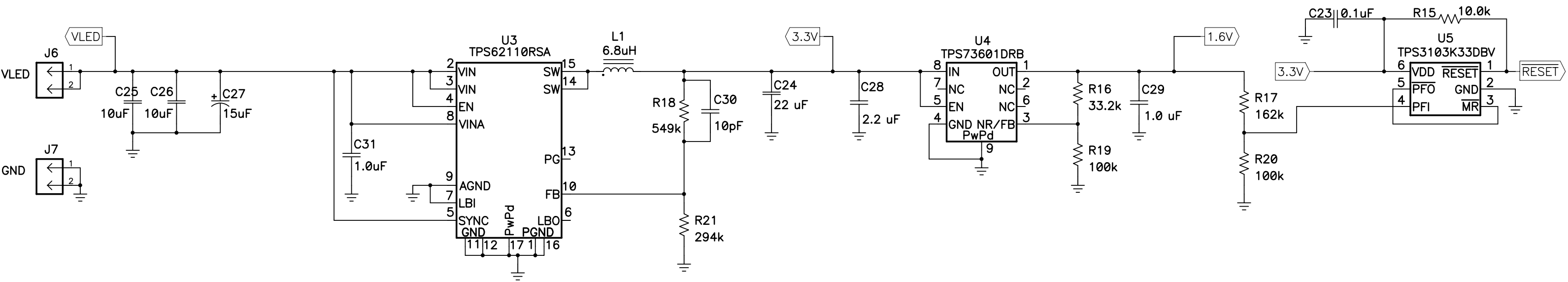

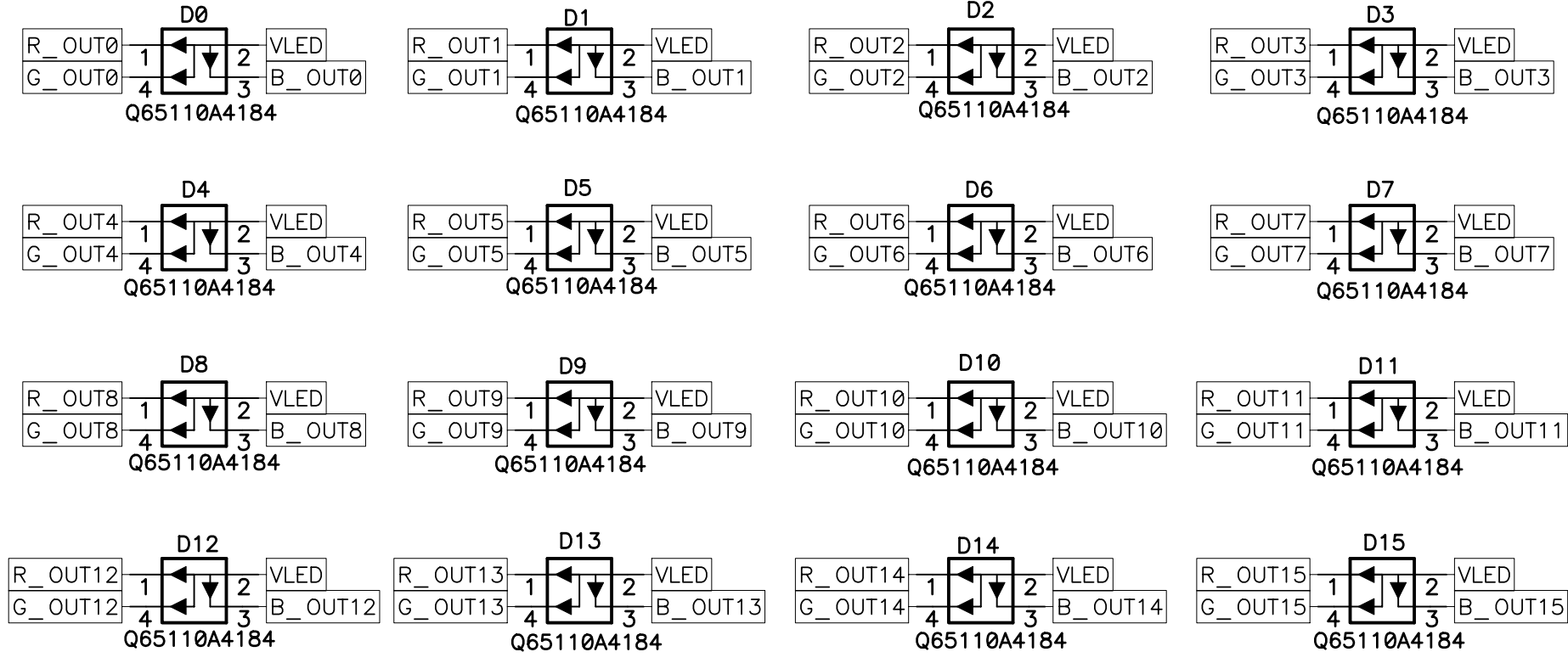
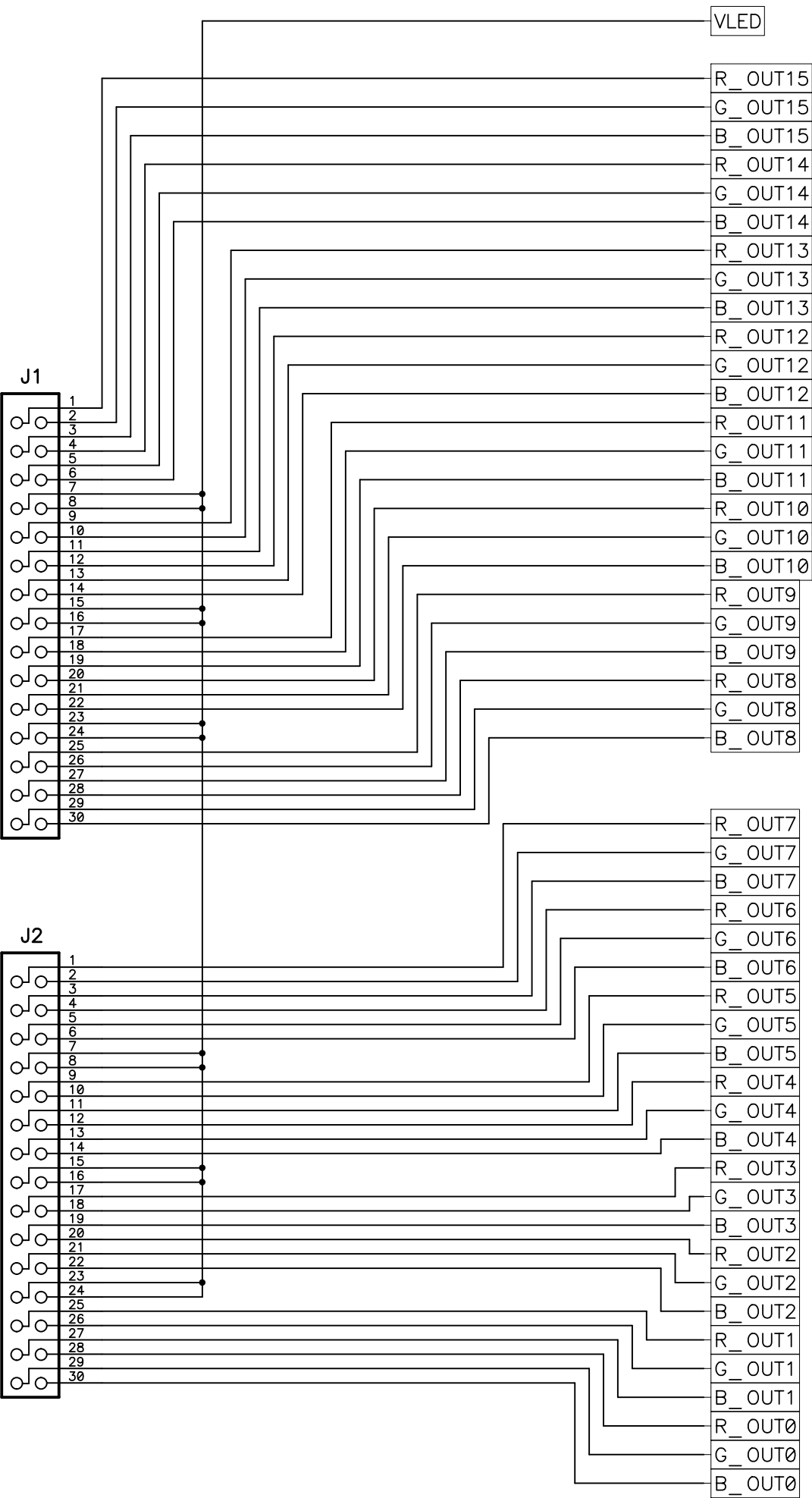

## 5.2 Bill of Materials

**Table 1. HPA248A Bill of Materials**

Count	RefDes	Value	Description	Size	Part Number	MFR
17	C1, C2, C7–C21, C23	0.1 $\mu$ F	Capacitor, Ceramic, 50V, X7R, 10%	0603	C1608X7R1H104K	TDK
2	C16, C22	10 $\mu$ F	Capacitor, Ceramic, 6.3V, X5R, 10%	0805	GRM219R60J106KE19D	Murata
1	C24	22 $\mu$ F	Capacitor, Ceramic, 16V, X7R, 20%	1210	C3225X7R1C226M	TDK
1	C28	2.2 $\mu$ F	Capacitor, Ceramic, 6.3V, X5R, 10%	0805	C2012X5R0J225KT	TDK
4	C29, C32–C34	1.0 $\mu$ F	Capacitor, Ceramic, 6.3V, X5R, 10%	0603	C3216X5R0J105KT	TDK
5	C3–C5, C25, C26	10 $\mu$ F	Capacitor, Ceramic, 25V, X5R, 10%	1210	GRM31CR61E106KA12L	Murata
1	C30	10 pF	Capacitor, Ceramic, 50V, C0G, 5%	0603	C1608C0G1H100DB	TDK
1	C31	1.0 $\mu$ F	Capacitor, Ceramic, 25V, X7R, 10%	0603	C1608X7R1E105K	TDK
2	C6, C27	15 $\mu$ F	Capacitor, POSCAP, 25V, 90m $\Omega$ , [temp], 20%	7343(D)	25TQC15MV	Sanyo
1	J1	2510-6002UB	Connector, Male Straight 2x5 pin, 100mil spacing, 4 Wall	0.338 $\times$ 0.788 in	2510-6002UB	3M
2	J2, J3	PTC30DBAN	Header, Male 2x15-pin, 100mil spacing (36-pin strip), Right-Angle	0.100 in $\times$ 15 $\times$ 2	PEC30DBAN	Sullins
1	J4		Header, 2x7 pin, 100mil spacing (36 pin strip)	0.100 in $\times$ 2X7		
3	J5–J7	PTC36SAAN	Header, 2-pin, 100mil spacing, (36-pin strip)	0.100 in $\times$ 2	PTC36SAAN	Sullins
1	JP1	PTC36SAAN	Header, 10 pin, 100mil spacing, (36-pin strip)	0.100 in $\times$ 2 $\times$ 10	PTC36SAAN	Sullins
3	JP2–JP4	PTC36SAAN	Header, 2-pin, 100mil spacing, (36-pin strip)	0.100 in $\times$ 2	PTC36SAAN	Sullins
1	L1	6.8 $\mu$ H	Inductor, SMT, 1.6A, 49.2m $\Omega$	0.276 sq	SLF7032T-6R8M1R6	TDK
2	R1, R2	2.2k	Resistor, Chip, 1/16W, 1%	0603	Std	Std
1	R16	33.2k	Resistor, Chip, 1/16W, 1%	0603	Std	Std
1	R17	162k	Resistor, Chip, 1/16W, 1%	0603	Std	Std
1	R18	549k	Resistor, Chip, 1/16W, 1%	0603	Std	Std
2	R19, R20	100k	Resistor, Chip, 1/16W, 1%	0603	Std	Std
1	R21	294k	Resistor, Chip, 1/16W, 1%	0603	Std	Std
3	R22–R24	2.37k	Resistor, Chip, 1/16W, 1%	0603	Std	Std
5	R3–R5, R7, R8	4.99k	Resistor, Chip, 1/16W, 1%	0603	Std	Std
8	R6, R9–R15	10.0k	Resistor, Chip, 1/16W, 1%	0603	Std	Std
17	TP1–TP10, TP13–TP19		Test Point, Red, Thru hole color keyed	0.100 $\times$ 0.100 in	5000	Keystone
2	TP11, TP12		Test Point, Black, Thru hole color keyed	0.100 $\times$ 0.100 in	5001	Keystone
1	U1	AT24C512N-10SU-2.7	IC, 512K, Serial EEPROM	SO-8	AT24C512N-10SU-2.7	Atmel
1	U2	TMS320VC5509APGE	IC, Digital Signal Processor	LQFP-144	TMS320VC5509APGE	TI
1	U3	TPS62110RSA	IC, Synchronous Step-Down Converter, 17V, 1.5A	QFN-16	TPS62110RSA	TI
1	U4	TPS73601DRB	IC, Cap-Free, NMOS, 400mA LDO regulator with reverse current protection	QFN-8	TPS73601DRB	TI
1	U5	TPS3103K33DBV	IC, Ultra Low Current/Supply, Voltage Supervisor	SOT23-6	TPS3103K33DBV	TI
3	U6–U8	TLC5942PWP	IC, 16 Chan LED Driver With Dot Correction/Grayscale PWM Control	TSSOP-28	TLC5942PWP	TI
1	Y1	12MHz	Clock Oscillator, SMD	0.386 $\times$ 0.547 inch	CMX-309FBC12.000M-UT	Citizen
1	--		PCB, 7.125 In $\times$ 4.3 In $\times$ 0.062 In		HPA248	Any
12	—		Shunt, 100-mil, Black	0.100	929950-00	3M
1			PCB Assembly		HPA249	TI

**Table 2. HPA249A Bill of Materials**

Count	RefDes	Value	Description	Size	Part Number	MFR
16	D0-D15	Q65110A4184	Diode, LED, 20mA, Common Anode (LATBT66B)	0.118 × 0.134	Q65110A4184	Osram
2	J1, J2	PPTC152LJBN-RC	Header, female, 2x5-pin, .100 inch, RA	0.500 × 1.520 inch	PPTC152LJBN-RC	Sullins
1	—		PCB, 2 In × 4 In × 0.062 In		HPA248	Any



## EVALUATION BOARD/KIT IMPORTANT NOTICE

Texas Instruments (TI) provides the enclosed product(s) under the following conditions:

This evaluation board/kit is intended for use for **ENGINEERING DEVELOPMENT, DEMONSTRATION, OR EVALUATION PURPOSES ONLY** and is not considered by TI to be a finished end-product fit for general consumer use. Persons handling the product(s) must have electronics training and observe good engineering practice standards. As such, the goods being provided are not intended to be complete in terms of required design-, marketing-, and/or manufacturing-related protective considerations, including product safety and environmental measures typically found in end products that incorporate such semiconductor components or circuit boards. This evaluation board/kit does not fall within the scope of the European Union directives regarding electromagnetic compatibility, restricted substances (RoHS), recycling (WEEE), FCC, CE or UL, and therefore may not meet the technical requirements of these directives or other related directives.

Should this evaluation board/kit not meet the specifications indicated in the User's Guide, the board/kit may be returned within 30 days from the date of delivery for a full refund. **THE FOREGOING WARRANTY IS THE EXCLUSIVE WARRANTY MADE BY SELLER TO BUYER AND IS IN LIEU OF ALL OTHER WARRANTIES, EXPRESSED, IMPLIED, OR STATUTORY, INCLUDING ANY WARRANTY OF MERCHANTABILITY OR FITNESS FOR ANY PARTICULAR PURPOSE.**

The user assumes all responsibility and liability for proper and safe handling of the goods. Further, the user indemnifies TI from all claims arising from the handling or use of the goods. Due to the open construction of the product, it is the user's responsibility to take any and all appropriate precautions with regard to electrostatic discharge.

**EXCEPT TO THE EXTENT OF THE INDEMNITY SET FORTH ABOVE, NEITHER PARTY SHALL BE LIABLE TO THE OTHER FOR ANY INDIRECT, SPECIAL, INCIDENTAL, OR CONSEQUENTIAL DAMAGES.**

TI currently deals with a variety of customers for products, and therefore our arrangement with the user **is not exclusive.**

TI assumes **no liability for applications assistance, customer product design, software performance, or infringement of patents or services described herein.**

Please read the User's Guide and, specifically, the Warnings and Restrictions notice in the User's Guide prior to handling the product. This notice contains important safety information about temperatures and voltages. For additional information on TI's environmental and/or safety programs, please contact the TI application engineer or visit [www.ti.com/esh](http://www.ti.com/esh).

No license is granted under any patent right or other intellectual property right of TI covering or relating to any machine, process, or combination in which such TI products or services might be or are used.

### FCC Warning

This evaluation board/kit is intended for use for **ENGINEERING DEVELOPMENT, DEMONSTRATION, OR EVALUATION PURPOSES ONLY** and is not considered by TI to be a finished end-product fit for general consumer use. It generates, uses, and can radiate radio frequency energy and has not been tested for compliance with the limits of computing devices pursuant to part 15 of FCC rules, which are designed to provide reasonable protection against radio frequency interference. Operation of this equipment in other environments may cause interference with radio communications, in which case the user at his own expense will be required to take whatever measures may be required to correct this interference.

### EVM WARNINGS AND RESTRICTIONS

It is important to operate this EVM within the input voltage range of 3.6 V to 17 V.

Exceeding the specified input range may cause unexpected operation and/or irreversible damage to the EVM. If there are questions concerning the input range, please contact a TI field representative prior to connecting the input power.

Applying loads outside of the specified output range may result in unintended operation and/or possible permanent damage to the EVM. Please consult the EVM User's Guide prior to connecting any load to the EVM output. If there is uncertainty as to the load specification, please contact a TI field representative.

During normal operation, some circuit components may have case temperatures greater than 60°C. The EVM is designed to operate properly with certain components above 60° C as long as the input and output ranges are maintained. These components include but are not limited to linear regulators, switching transistors, pass transistors, and current sense resistors. These types of devices can be identified using the EVM schematic located in the EVM User's Guide. When placing measurement probes near these devices during operation, please be aware that these devices may be very warm to the touch.

Mailing Address: Texas Instruments, Post Office Box 655303, Dallas, Texas 75265  
Copyright 2007, Texas Instruments Incorporated

## IMPORTANT NOTICE

Texas Instruments Incorporated and its subsidiaries (TI) reserve the right to make corrections, modifications, enhancements, improvements, and other changes to its products and services at any time and to discontinue any product or service without notice. Customers should obtain the latest relevant information before placing orders and should verify that such information is current and complete. All products are sold subject to TI's terms and conditions of sale supplied at the time of order acknowledgment.

TI warrants performance of its hardware products to the specifications applicable at the time of sale in accordance with TI's standard warranty. Testing and other quality control techniques are used to the extent TI deems necessary to support this warranty. Except where mandated by government requirements, testing of all parameters of each product is not necessarily performed.

TI assumes no liability for applications assistance or customer product design. Customers are responsible for their products and applications using TI components. To minimize the risks associated with customer products and applications, customers should provide adequate design and operating safeguards.

TI does not warrant or represent that any license, either express or implied, is granted under any TI patent right, copyright, mask work right, or other TI intellectual property right relating to any combination, machine, or process in which TI products or services are used. Information published by TI regarding third-party products or services does not constitute a license from TI to use such products or services or a warranty or endorsement thereof. Use of such information may require a license from a third party under the patents or other intellectual property of the third party, or a license from TI under the patents or other intellectual property of TI.

Reproduction of TI information in TI data books or data sheets is permissible only if reproduction is without alteration and is accompanied by all associated warranties, conditions, limitations, and notices. Reproduction of this information with alteration is an unfair and deceptive business practice. TI is not responsible or liable for such altered documentation. Information of third parties may be subject to additional restrictions.

Resale of TI products or services with statements different from or beyond the parameters stated by TI for that product or service voids all express and any implied warranties for the associated TI product or service and is an unfair and deceptive business practice. TI is not responsible or liable for any such statements.

TI products are not authorized for use in safety-critical applications (such as life support) where a failure of the TI product would reasonably be expected to cause severe personal injury or death, unless officers of the parties have executed an agreement specifically governing such use. Buyers represent that they have all necessary expertise in the safety and regulatory ramifications of their applications, and acknowledge and agree that they are solely responsible for all legal, regulatory and safety-related requirements concerning their products and any use of TI products in such safety-critical applications, notwithstanding any applications-related information or support that may be provided by TI. Further, Buyers must fully indemnify TI and its representatives against any damages arising out of the use of TI products in such safety-critical applications.

TI products are neither designed nor intended for use in military/aerospace applications or environments unless the TI products are specifically designated by TI as military-grade or "enhanced plastic." Only products designated by TI as military-grade meet military specifications. Buyers acknowledge and agree that any such use of TI products which TI has not designated as military-grade is solely at the Buyer's risk, and that they are solely responsible for compliance with all legal and regulatory requirements in connection with such use.

TI products are neither designed nor intended for use in automotive applications or environments unless the specific TI products are designated by TI as compliant with ISO/TS 16949 requirements. Buyers acknowledge and agree that, if they use any non-designated products in automotive applications, TI will not be responsible for any failure to meet such requirements.

Following are URLs where you can obtain information on other Texas Instruments products and application solutions:

<b>Products</b>		<b>Applications</b>	
Amplifiers	<a href="http://amplifier.ti.com">amplifier.ti.com</a>	Audio	<a href="http://www.ti.com/audio">www.ti.com/audio</a>
Data Converters	<a href="http://dataconverter.ti.com">dataconverter.ti.com</a>	Automotive	<a href="http://www.ti.com/automotive">www.ti.com/automotive</a>
DSP	<a href="http://dsp.ti.com">dsp.ti.com</a>	Broadband	<a href="http://www.ti.com/broadband">www.ti.com/broadband</a>
Interface	<a href="http://interface.ti.com">interface.ti.com</a>	Digital Control	<a href="http://www.ti.com/digitalcontrol">www.ti.com/digitalcontrol</a>
Logic	<a href="http://logic.ti.com">logic.ti.com</a>	Military	<a href="http://www.ti.com/military">www.ti.com/military</a>
Power Mgmt	<a href="http://power.ti.com">power.ti.com</a>	Optical Networking	<a href="http://www.ti.com/opticalnetwork">www.ti.com/opticalnetwork</a>
Microcontrollers	<a href="http://microcontroller.ti.com">microcontroller.ti.com</a>	Security	<a href="http://www.ti.com/security">www.ti.com/security</a>
RFID	<a href="http://www.ti-rfid.com">www.ti-rfid.com</a>	Telephony	<a href="http://www.ti.com/telephony">www.ti.com/telephony</a>
Low Power Wireless	<a href="http://www.ti.com/lpw">www.ti.com/lpw</a>	Video & Imaging	<a href="http://www.ti.com/video">www.ti.com/video</a>
		Wireless	<a href="http://www.ti.com/wireless">www.ti.com/wireless</a>

Mailing Address: Texas Instruments, Post Office Box 655303, Dallas, Texas 75265  
Copyright © 2007, Texas Instruments Incorporated