

LOC		DIST		REVISIONS			
P	LTR	DESCRIPTION	DATE	DMN	APVD		
H		REV PER ECO 15-005909	5-19-15	CT	DM		

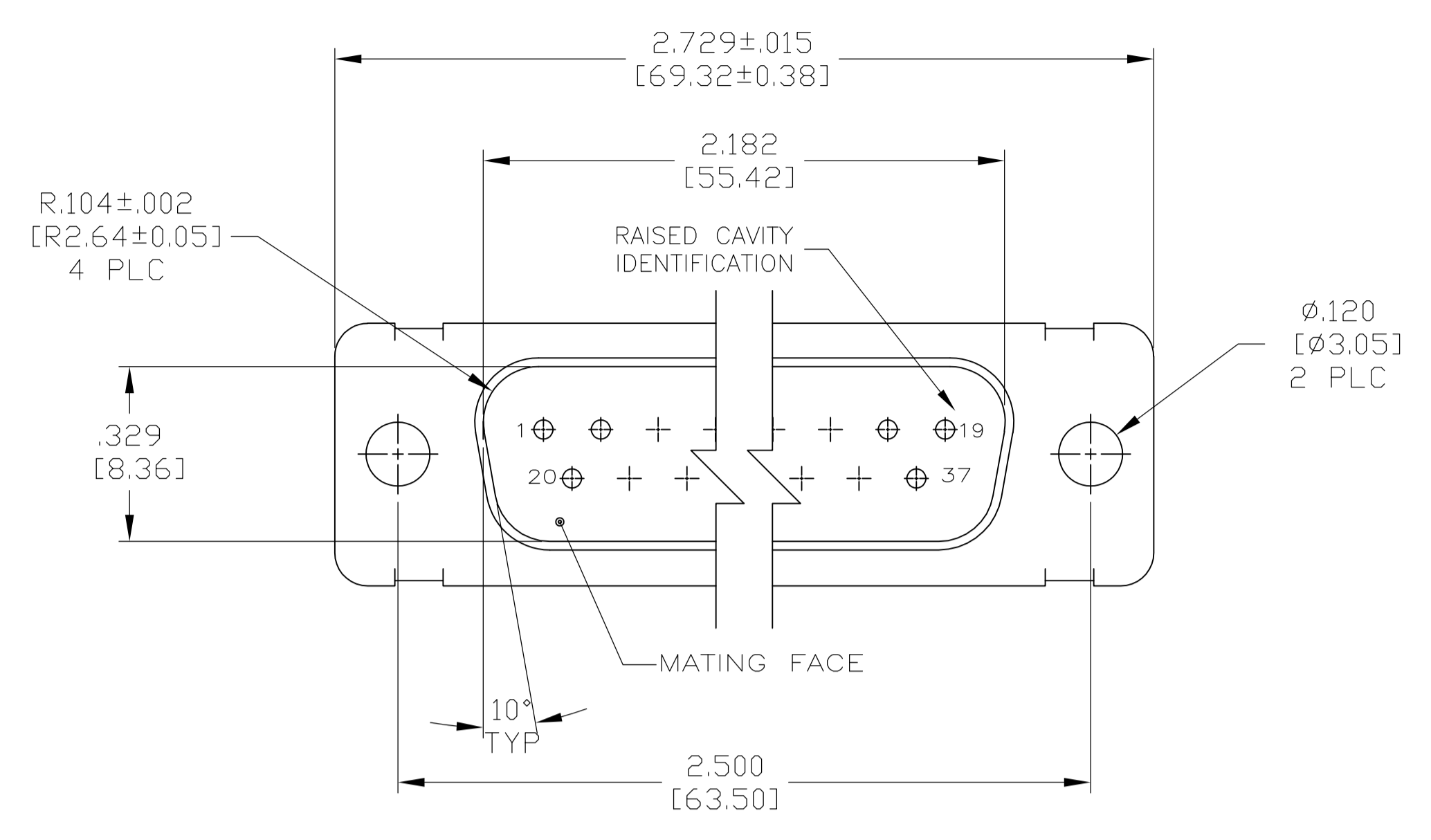

1. THIS CONNECTOR ASSEMBLY IS SUPPLIED WITH Be Cu CONTACT RETENTION CLIPS INSTALLED IN THE INSERT ASSEMBLY.
  2. THIS CONNECTOR ASSEMBLY MATES WITH ANY PLUG CONNECTOR WITH THE SAME INSERT ARRANGEMENT AND DIMENSIONAL REQUIREMENTS PER MIL-C-24308.
  3. MARKED WITH .047 [1.19]-.062 [1.57] HIGH CHARACTERS. FAR SIDE REFERS TO THE WIDE SIDE OF THE KEYSTONE. NEAR SIDE REFERS TO THE NARROW SIDE OF THE KEYSTONE.
  4. MAXIMUM WIRE INSULATION TO BE USED WITH THIS CONNECTOR ASSEMBLY IS .054 [1.37] DIAMETER.
5. SPECIAL REQUIREMENTS PER BOEING 1A01 DOCUMENT.
6. BUILT TO ORDER, NO INVENTORY OF THIS PART NUMBER IS TO BE KEPT. SINGLE LOT DATE CODE REQUIRED.

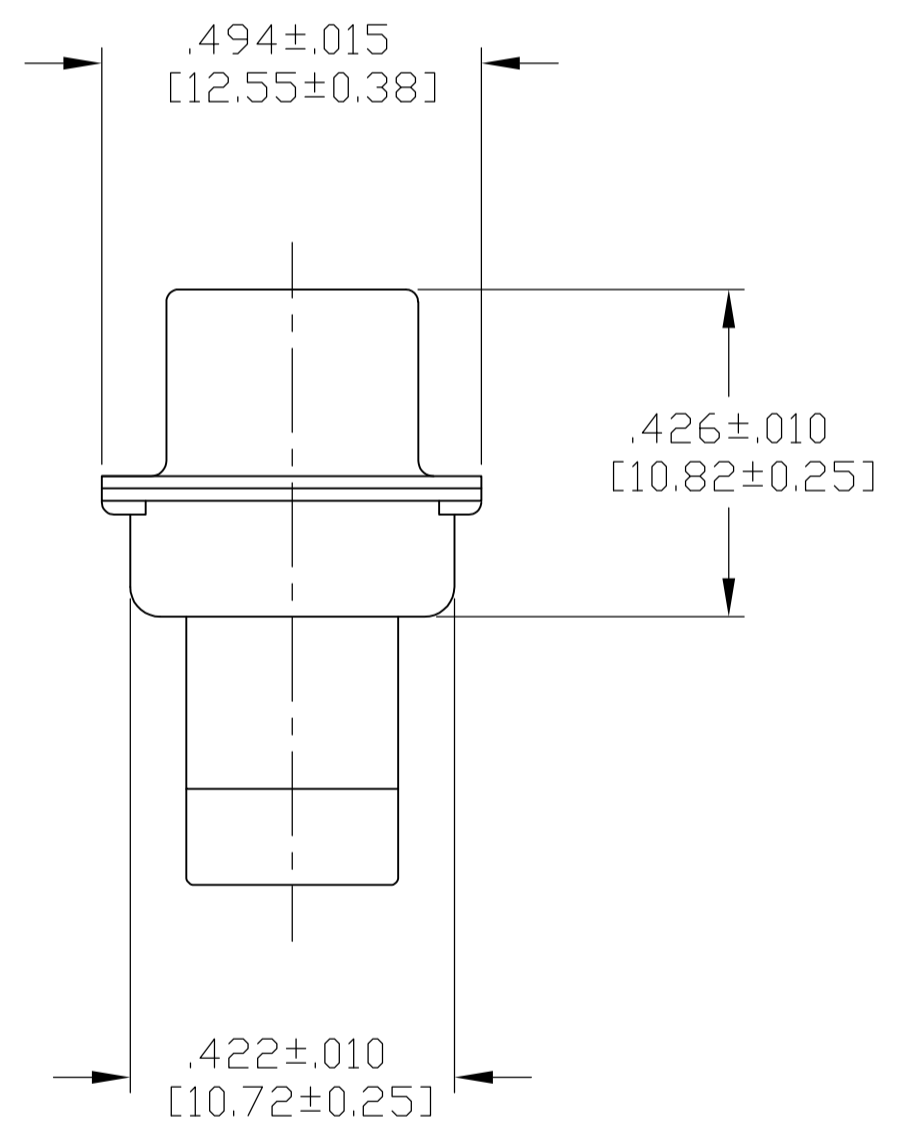
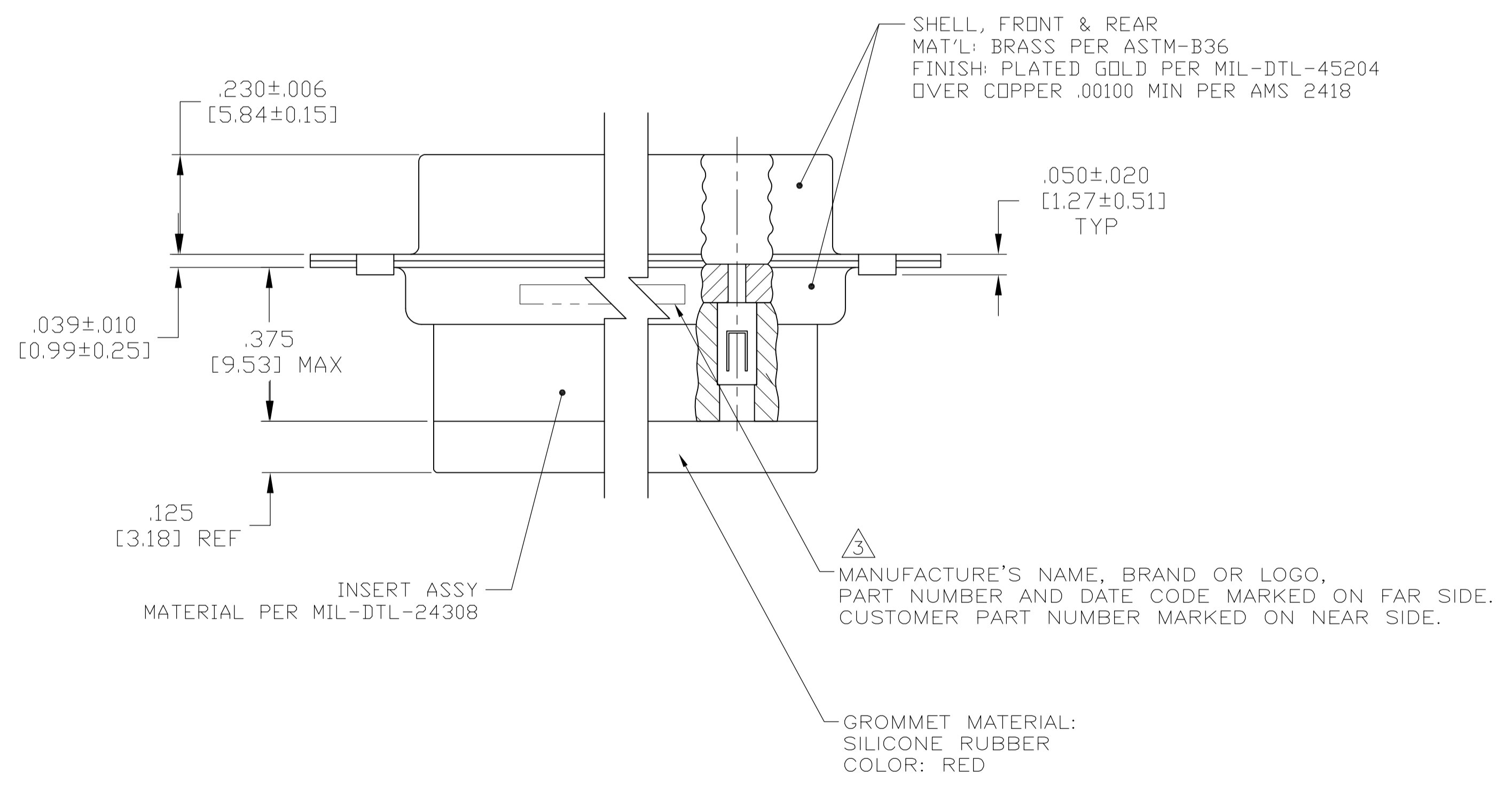

3. MANUFACTURE'S NAME, BRAND OR LOGO, PART NUMBER AND DATE CODE MARKED ON FAR SIDE. CUSTOMER PART NUMBER MARKED ON NEAR SIDE.

GROMMET MATERIAL: SILICONE RUBBER COLOR: RED

6 7	1A01-029PHW	1-211641-1
--	---	211641-4
6 7	1A01-029PHA	211641-1
REMARKS	CUSTOMER MARKING	PART NUMBER

DIMENSIONS:		TOLERANCES UNLESS OTHERWISE SPECIFIED:		APPROVALS:		DRAWING NO.		RESTRICTED TO	
INCHES				DMN	DATE	SIZE	CAGE CODE	DRAWING NO.	REV
		0 PLC	± -	C.C. THOMAS	4-9-09	A1	00779	211641	
		1 PLC	± -	CHK	4-9-09				
		2 PLC	± -	APP'D	4-9-09				
		3 PLC	± .005 [0.13]	RELEAS					
		4 PLC	± -	PRODUCT SPEC					
		ANGLES	± -	APPLICATION SPEC					
			± -	WEIGHT					
MATERIAL	SEE CALLOUTS	FINISH	SEE CALLOUTS	CUSTOMER DRAWING		SCALE	4:1	SHEET	1 OF 1