

World's First Wide-Range 6-Axis MEMS MotionTracking™ Device for Sports and High Impact Applications

GENERAL DESCRIPTION

Many of today's wearable and sports solutions, which analyze the motion of a user's golf or tennis swings, soccer ball kicks, or basketball activities, require higher than currently available ± 2000 dps (degrees per second) FSR for gyroscope and $\pm 16g$ FSR for accelerometer to better insure that critical data is not lost at the point of high impact or high speed rotation. The ICM-20601 SoC offers the smallest size, lowest profile and lowest power in conjunction with industry leading high FSR.

With an extended FSR range of ± 4000 dps for gyroscope and $\pm 32g$ for accelerometer, the ICM-20601 enables precise analysis of contact sports applications providing continuous motion sensor data before, during and after impact providing more accurate feedback

The ICM-20601 is the world's first wide-range 6-axis MotionTracking device for Sports and other High Impact applications. It is available in a 3x3x0.75mm 16-pin LGA package.

ORDERING INFORMATION

PART	TEMP RANGE	PACKAGE
ICM-20601†	-40°C to +85°C	16-Pin LGA

†Denotes RoHS and Green-Compliant Package

BLOCK DIAGRAM

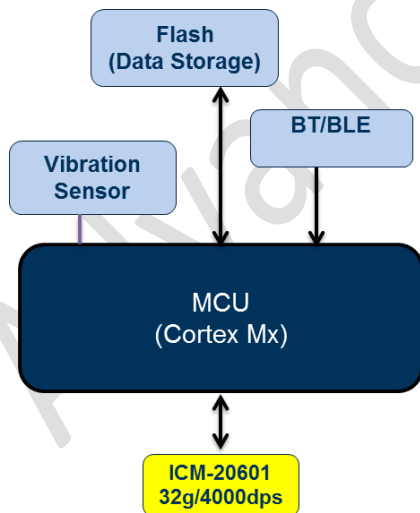

Motion Analysis Pod Architecture

APPLICATIONS

- Sports
- Wearable Sensors
- High Impact Applications

FEATURES

- 3-Axis Gyroscope with Programmable FSR of ± 500 dps, ± 100 dps, ± 2000 dps and ± 4000 dps
- 3-Axis Accelerometer with Programmable FSR of $\pm 4g$, $\pm 8g$, $\pm 16g$ and $\pm 32g$
- User-programmable interrupts
- Wake-on-motion interrupt for low power operation of applications processor
- 512 byte FIFO buffer enables the applications processor to read the data in bursts
- On-Chip 16-bit ADCs and Programmable Filters
- Host interface: 8MHz SPI or 400kHz Fast Mode I2C
- Digital-output temperature sensor
- VDD operating range of 1.71 to 3.45V
- MEMS structure hermetically sealed and bonded at wafer level
- RoHS and Green compliant

TYPICAL OPERATING CIRCUIT

