

Hardware Version V1.2

HARDWARE MANUAL

+



+

+

TMCM-1311

1-Axis Stepper
Closed Loop Controller/Driver
3.0 A / 48 V
Encoder Input
18 GPIOs
USB, CAN, RS485

+

TRINAMIC Motion Control GmbH & Co. KG
Hamburg, Germany

www.trinamic.com

Table of Contents

1	Features	3
2	Order Codes	5
3	Mechanical and Electrical Interfacing	6
3.1	Dimensions	6
3.2	Connectors	7
3.2.1	Power Connector	8
3.2.2	Motor Connector	8
3.2.3	Encoder Connector	9
3.2.4	Reference Switch Connector	10
3.2.5	Step/Dir IN Connector	10
3.2.6	I/O Connectors 0 and 1	10
3.2.7	USB Connector	11
3.2.8	CAN / RS485 Connector	12
3.3	Power Supply	13
3.3.1	Adding an Electrolytic Capacitor	13
3.4	Communication	14
3.4.1	RS485	14
3.4.2	CAN	16
3.4.3	USB	17
3.5	Inputs and Outputs	18
3.5.1	Encoder Input	18
3.5.2	Reference Switch Inputs	18
3.5.3	General Purpose Inputs	19
3.5.4	General Purpose Outputs	19
4	On-Board LEDs	20
5	Operational Ratings	21
6	Functional Description	22
7	Life Support Policy	23
8	Revision History	24
8.1	Document Revision	24
8.2	Hardware Revision	24
9	References	24

1 Features

The TMCM-1311 is a single axis stepper motor controller and driver standalone board with USB, CAN and RS485 interface. It supports motor currents up to 3A RMS and supply voltages up to 48V nominal. The module offers inputs for an incremental a/b/n (TTL, open-collector, and differential inputs) encoder. In addition, there are dedicated stop switch inputs and 8 general purpose inputs and 8 general purpose outputs.

MAIN CHARACTERISTICS

Bipolar stepper motor driver

- Up to 256 microsteps per full step
- High-efficient operation, low power dissipation
- Dynamic current control
- Integrated protection: overtemperature and undervoltage
- stallGuard2™ feature for stall detection

Encoder

- Encoder input for incremental a/b/n (TTL, OC or diff.)

Interfaces

- RS485 2-wire communication interface
- CAN 2.0B communication interface (4x DIP-switch for CAN / RS485 address setting or other settings)
- USB 2.0 full-speed (12Mbit/s) communication interface (mini-USB connector)
- Encoder input: incremental a/b/n (TTL, OC or diff.)
- Dedicated STOP_L / STOP_R inputs
- Up to 8 multi-purpose inputs (+24V compatible, incl. 2 dedicated analog inputs)
- Up to 8 multi-purpose outputs (Open-drain, incl. 2 outputs for currents up to 1A)

Software

- TMCL™ remote (direct mode) and standalone operation with memory for up to 1024 TMCL commands
- Closed-loop support
- Fully supported by TMCL-IDE (PC based integrated development environment)

Electrical data

- Supply voltage: +12V... +48V DC
- Motor current: up to 3A RMS (programmable)

Mechanical data

- Board size: 110mm x 110mm, height 26.3mm max.

Please refer to separate TMCM-1311 Firmware Manual for additional information.

TRINAMIC FEATURES – CLOSED LOOP MODE

The TMCM-1311 is mainly designed to run 2-phase stepper motors in closed loop mode. It offers an automatic motor load adaption in positioning mode, velocity mode, and torque mode, which is based on encoder feedback and closed loop control software for analysis, error detection and error correction.

The closed loop mode operation combines the advantages of a stepper driver system with the benefits of a servo drive. Thus, the TMCM-1311 is able to satisfy ambitious requirements in reliability and precision and can be used in several industrial demanding applications.

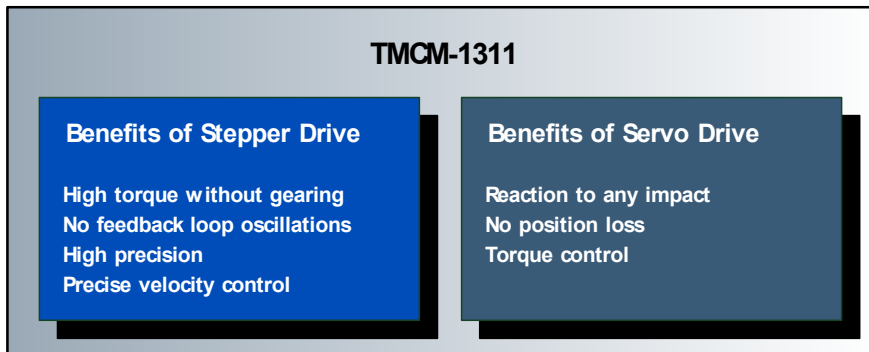

Figure 1.1 TMCM-1311 characteristics in closed loop mode

THE TRINAMIC CLOSED LOOP MODE OPERATION

- prevents the motor from stall and step loss caused by too high load or high velocity.
- adapts the current amplitude to each motor load which is within the ranges predetermined by motor and controller/driver board characteristics.
- achieves a higher torque output than in open loop mode.
- guarantees a precise and fast positioning.
- enables velocity and positioning error compensation.

Using the TMCM-1311, energy will be saved and the motor will be kept cool.

2 Order Codes

Order code	Description	Size of unit (mm ³)
TMCM-1311- <i>option</i>	1-axis closed-loop bipolar stepper motor controller / driver module	110 x 110 x 26.5

Table 2.1 Order codes

The following options are available:

Firmware option	Description	Order code example:
-TMCL	Module pre-programmed with TMCL firmware	TMCM-1311- <i>TMCL</i>

Table 2.2 Firmware options

A cable loom set is available for this module:

Order code	Description
TMCM-1311-CABLE	Cable loom for TMCM-1311. Contains (see chapter 3.2, also): <ul style="list-style-type: none"> - 1x cable loom for power connector - 1x cable loom for reference switch connector - 1x cable loom for step/direction input connector - 1x cable loom for encoder input connector - 1x cable loom for motor connector - 2x cable loom for I/O connector 0+1 - 1x USB type A connector to mini-USB type B connector cable

Table 2.3 Cable loom order code

3 Mechanical and Electrical Interfacing

3.1 Dimensions

The TMCM-1311 has an overall size of 110mm x 110mm and offers four mounting holes with 4mm diameter. Maximum height (without mating connectors and cable looms) is about 26.3mm.

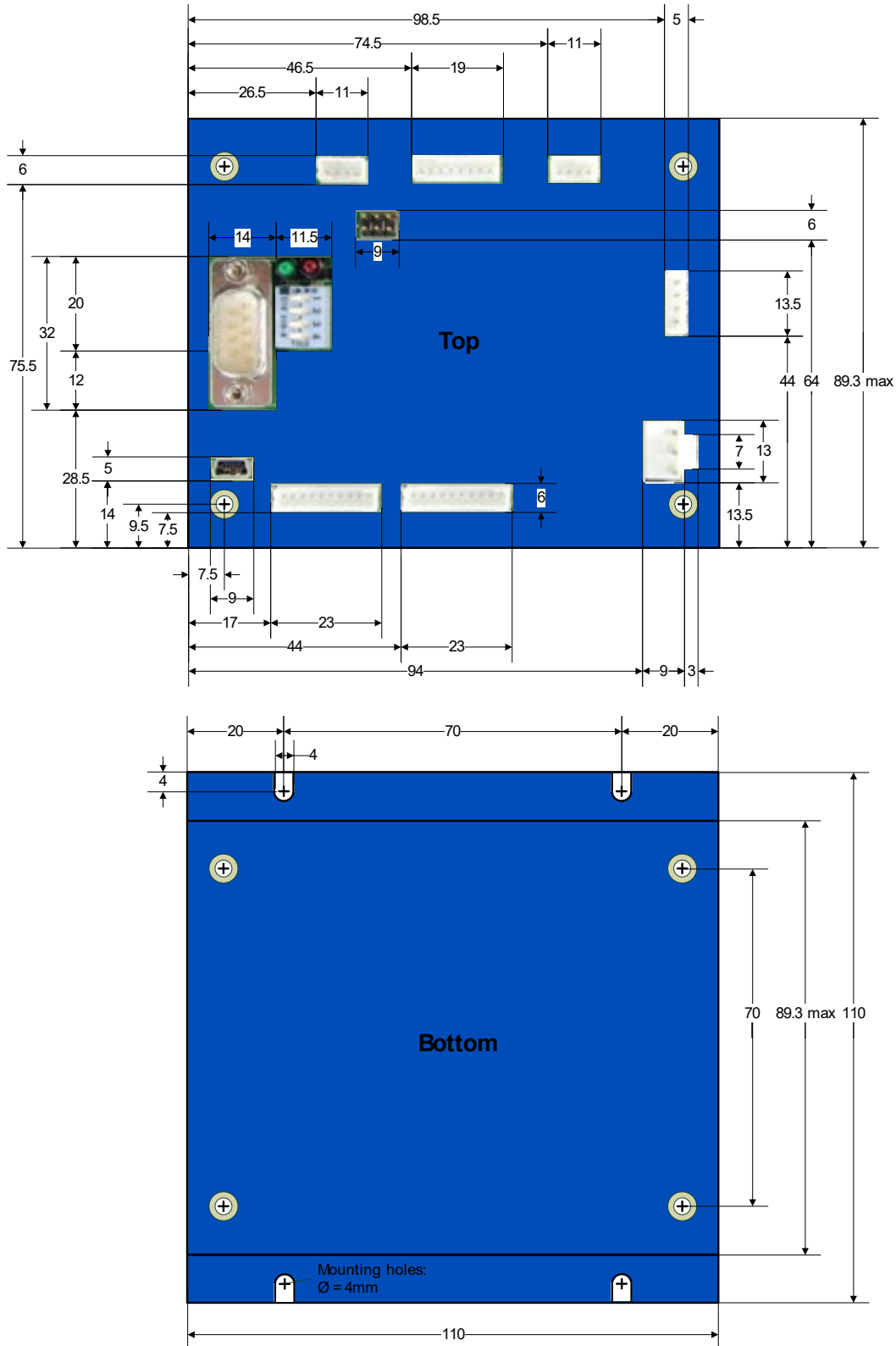

Figure 3.1 Dimensions of TMCM-1311 (all values in mm).

3.2 Connectors

The TMCM-1311 has nine connectors altogether:

- one detachable connector for the motor
- one detachable connector for the corresponding encoder input
- one detachable connector for the reference switches
- two detachable I/O connectors
- one detachable power connector
- one mini-USB connector
- one connector for RS485 and CAN
- one detachable connector for external step/direction in

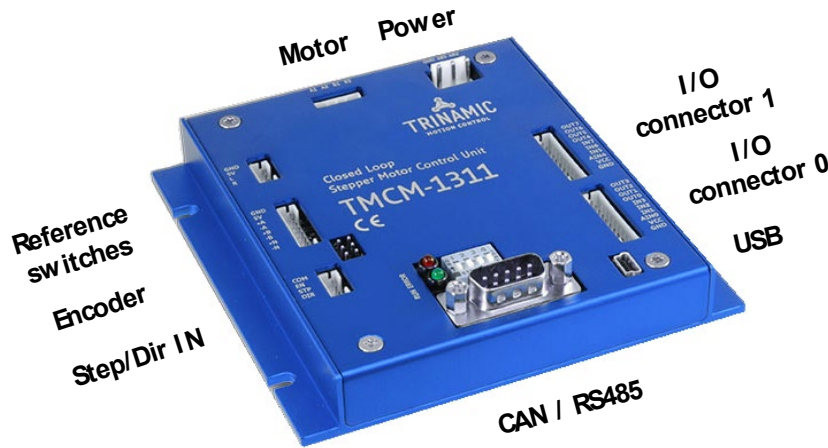

Figure 3.2 TMCM-1311 connectors

OVERVIEW OF CONNECTOR AND MATING CONNECTOR TYPES

Label	Connector type	Mating connector type
Power connector	JST B3P-VH (JST VH series, 3pins, 3.96mm pitch)	Connector housing: JST VHR-3N Contacts: JST SVH-21T-P1.1 Wire: 0.83mm ² , AWG 18
Motor connector	JST B4B-EH-A (JST EH series, 4pins, 2.5mm pitch)	Connector housing: JST EHR-4 Contacts: JST SEH-001T-P0.6 Wire: 0.33mm ² , AWG 22
Encoder connector	JST B8B-PH-K-S (JST PH series, 4pins, 2mm pitch)	Connector housing: JST PHR-8 Contacts: JST SPH-002T-P0.5S Wire: 0.22mm ² , AWG 24
Reference switch connector	JST B4B-PH-K-S (JST PH series, 4pins, 2mm pitch)	Connector housing: JST PHR-4 Contacts: JST SPH-002T-P0.5S Wire: 0.22mm ² , AWG 24
Step/Dir In connector	JST B4B-PH-K-S (JST PH series, 4pins, 2mm pitch)	Connector housing: JST PHR-4 Contacts: JST SPH-002T-P0.5S Wire: 0.22mm ² , AWG 24
I/O connector 0 + 1	JST B10B-PH-K-S (JST PH series, 10pins, 2mm pitch)	Connector housing: JST PHR-10 Contacts: JST SPH-002T-P0.5S Wire: 0.22mm ² , AWG 24
Mini-USB connector	Mini USB Type B vertical receptacle	Any standard mini-USB plug
CAN / RS485 connector	Male D-SUB 9-pin	Any standard D-SUB female 9-pin

Table 3.1 Connectors and mating connectors, contacts and applicable wire

3.2.1 Power Connector

The module has a single power connector with the option to have separate supplies for driver electronics and the digital controller part. A single supply voltage is sufficient. All further voltages required e.g. for the digital components are generated on-board.

	Pin	Label	Direction	Description
	1	GND	Power (GND)	Common system supply and signal ground
	2	V _{DRIVER}	Power (supply input)	Stepper driver supply voltage. Without this voltage the stepper driver and any motor connected will not be energized.
	3	V _{DIGITAL}	Power (supply input)	Supply voltage for everything else apart from the stepper motor driver. The on-board voltage regulator generates the necessary voltages for the digital circuits from this supply. The pin can be left unconnected. In this case a diode between V _{DRIVER} and V _{DIGITAL} ensures the supply for the digital parts. ATTENTION: <ul style="list-style-type: none"> - The diode has a current rating of 3A. As V_{DIGITAL} is available at the I/O connectors and at the reference switch connectors also, always connect this pin to positive supply voltage in case substantial amount of current is withdrawn from these pins for external circuits. - It is expected that V_{DIGITAL} and V_{DRIVER} are connected to the same power supply output when both pins are used. Otherwise please ensure that V_{DIGITAL} is always equal or higher than V_{DRIVER} when connected (due to the diode).

Table 3.1 Power connector

3.2.2 Motor Connector

A 4 pin JST EH series connector is available for motor connection.

	Pin	Label	Direction	Description
	1	A1	Output	Pin 1 of motor coil A
	2	A2	Output	Pin 2 of motor coil A
	3	B1	Output	Pin 1 of motor coil B
	4	B2	Output	Pin 2 of motor coil B

Table 3.2 Motor connector

3.2.3 Encoder Connector

A dedicated encoder input connector is available. Connector type is JST PH series 8pin with 2mm pitch.

The following encoders are supported in incremental A/B/N interface configuration:

- encoders with incremental differential (RS422) output signals with or without zero/index channel
- encoders with incremental single ended (TTL or open collector) output signals with or without zero/index channel

	Pin	Label	Direction	Description
	1	GND	Power (GND)	Signal and system ground
	2	+5V	Power (supply output)	+5V output for external circuit
	3	A+	Input	Encoder channel A+ input (differential, non-inverting)
	4	A-	Input	Encoder channel A- input (differential, inverting)
	5	B+	Input	Encoder channel B+ input (differential, non-inverting)
	6	B-	Input	Encoder channel B- input (differential, inverting)
	7	N+	Input	Encoder zero / index channel input (differential, non-inverting)
	8	N-	Input	Encoder zero / index channel input (differential, inverting)

Table 3.3 Encoder connector (configuration for encoders with incremental A/B/N output)

For encoders with +5V supply the required +5V output is also available via this connector (max. 100mA per connector).

3.2.3.1.1 Differential A/B/N Encoder Signals

For differential encoder signals connect all differential signals (A+ and A-, B+ and B- and optional N+ and N-) to the respective connector input pins. Usually on-board line termination should be also installed for differential signals. Therefore, close all three jumpers for the 120R line termination of the respective differential encoder input.

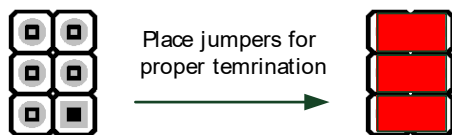

Please refer to the encoder manufacturer data sheet for the correct interface settings.

Figure 3.3 Encoder input termination

3.2.3.1.2 Single Ended A/B/N Encoder Signals

For single ended encoders (TTL or open collector signals) connect the encoder signals A, B and optional N to the positive / non-inverting differential inputs of the encoder connector A+ / B+ / N+.

NECESSARY CONNECTIONS			
Encoder sign.	Encoder connector		
	Pin	Label	Description
A	3	A+	Encoder channel A+ input (differential, non-inverting)
B	5	B+	Encoder channel B+ input (differential, non-inverting)
N/I (optional)	7	N+	Encoder zero / index channel input (differential, non-inverting)

Table 3.4 How to connect single ended encoders

The pins A-, B-, and N- of the encoder connector may be left unconnected.

3.2.4 Reference Switch Connector

A separate reference / limit switch input connector is available. Connector type is JST PH series 4pin with 2mm pitch.

	Pin	Label	Direction	Description
	1	GND	Power (GND)	Signal and system ground
	2	+5V	Power (supply output)	+5V supply output for external encoder and reference switch circuit.
	3	REF_L	Input	Input for reference / limit switch left
	4	REF_R	Input	Input for reference / limit switch right

Table 3.5 Reference switch connector

3.2.5 Step/Dir IN Connector

A separate Step / Direction input connector is available. Connector type is JST PH series 4pin with 2mm pitch.

	Pin	Label	Direction	Description
	1	COM	Input	Common supply for the opto-coupler inputs (+5V... +24V)
	2	ENABLE	Input	Enable signal input (function depends on firmware)
	3	STEP	Input	Step signal input (connected to step input of TMC262 driver IC)
	4	DIR	Input	Direction signal (connected to direction input of TMC262 driver IC)

Table 3.6 Step/Dir In connector

3.2.6 I/O Connectors 0 and 1

The module offers two I/O connectors (JST PH series 8pin with 2mm pitch). Number and type of inputs, outputs and supply are the same for both connectors. It is sufficient to use just one connector if only few I/Os are required. This simplifies cabling.

3.2.6.1 I/O Connector 0

	Pin	Label	Direction	Description
	1	GND	Power (GND)	GND
	2	VCC	Power (supply output)	Connected to V _{DIGITAL} of Power connector. Please note: max. current is 500mA (protected via on-board 500mA polyfuse)
	3	AIN0	Input	Dedicated analog input, input voltage range: 0... +10V, resolution: 12bit (0... 4095)
	4	IN1	Input	Digital input (+24V compatible)
	5	IN2	Input	Digital input (+24V compatible)
	6	IN3	Input	Digital input (+24V compatible)
	7	OUT0	Output	Open-drain output (max. 100mA) Integrated freewheeling diode
	8	OUT1	Output	Open-drain output (max. 100mA) Integrated freewheeling diode
	9	OUT2	Output	Open-drain output (max. 100mA) Integrated freewheeling diode
	10	OUT3	Output	Open-drain output (max. 1A) Integrated freewheeling diode

Table 3.7 I/O connector 0

3.2.6.2 I/O Connector 1

	Pin	Label	Direction	Description
	1	GND	Power (GND)	GND
	2	VCC	Power (supply output)	Connected to V _{DIGITAL} of Power connector. Please note: max. current is 500mA (protected via on-board 500mA polyfuse)
	3	AIN4	Input	Dedicated analog input, input voltage range: 0... +10V, resolution: 12bit (0... 4095)
	4	IN5	Input	Digital input (+24V compatible)
	5	IN6	Input	Digital input (+24V compatible)
	6	IN7	Input	Digital input (+24V compatible)
	7	OUT4	Output	Open-drain output (max. 100mA) Integrated freewheeling diode
	8	OUT5	Output	Open-drain output (max. 100mA) Integrated freewheeling diode
	9	OUT6	Output	Open-drain output (max. 100mA) Integrated freewheeling diode
10	OUT7	Output	Open-drain output (max. 1A) Integrated freewheeling diode	

Table 3.8 I/O connector 1

3.2.7 USB Connector

An USB (device) interface is available via a mini-USB connector. This module supports USB 2.0 full-speed (12Mbit/s) connections.

The on-board digital core logic (mainly processor and EEPROM) will be powered via USB in case no other power supply is connected. This is useful for setting parameters and downloading TMCL programs or for performing firmware updates. Using a USB connection to the host, the tasks outlined above can be carried out inside a machine while the machine is powered off. Refer to chapter 3.4.1, please.

	Pin	Label	Direction	Description
	1	VBUS	Power (+5V input)	+5V supply from Host
	2	D-	Bi-directional	USB Data -
	3	D+	Bi-directional	USB Data +
	4	ID		Connected to signal and system ground
5	GND	Power (GND)	Signal and System ground	

Table 3.9 USB connector

3.2.8 CAN / RS485 Connector

The TMCM-1311 offers one 9-pin male D-SUB connector for CAN and RS485 communication. An on-board bi-stable relay allows switching between CAN and RS485 connector pin-assignment in software. This bi-stable relay remembers its state even when un-powered. Hence, the configuration of the pin-assignment for either CAN or RS485 has to be done only once.

3.2.8.1 CAN Connector

If selected, a CAN 2.0B interface is available via the on-board 9-pin male D-SUB connector. Only three pins of the connector are used. The pin assignment of these three pins is in accordance with the *CiA Draft Recommendation Part 1: Cabling and connector pin assignment*.

	Pin	Label	Direction	Description	
	1				
	2	CAN_L	Bi-directional	Differential CAN bus signal (inverting)	
	3	GND	Power (GND)	Signal and system ground	
	4				
	5				
	6				
	7	CAN_H	Bi-directional	Differential CAN bus signal (non-inverting)	
	8				
	9				

Table 3.10 CAN connector

3.2.8.2 RS485 Connector

If selected, an RS485 interface is available via the 9-pin male D-SUB connector. The module supports 2-wire RS485 communication. Only three pins of the connector are used.





	Pin	Label	Direction	Description	
	1				
	2	RS485-	Bi-directional	Differential RS485 bus signal (inverting)	
	3	GND	Power (GND)	Signal and system ground	
	4				
	5				
	6				
	7	RS485+	Bi-directional	Differential RS485 bus signal (non-inverting)	
	8				
	9				

Table 3.11 RS485 connector

3.3 Power Supply

For proper operation care has to be taken with regard to power supply concept and design. The TMCM-1311 includes about 40µF of supply filter capacitors. These are ceramic capacitors which have been selected for high reliability and long life time. Further, the module includes a 48V suppressor diode and additional varistor for over-voltage protection.

CAUTION!

	<p>Add external power supply capacitors!</p> <p>The module contains a number of capacitors for power supply filtering. Nevertheless, depending on operation and selected motors the resulting capacity might be not large enough for proper supply buffering. Note: upper supply voltage limit must not be exceeded – not even for a short period of time! In this context it should be taken into account that the module will transfer energy from the motor back into the supply rail when the motor is working as generator e.g. during deceleration or brake conditions. In case the power supply capacitors are not sufficient for limiting power supply rising, additional measures have to be considered (e.g. suppressor diodes, brake resistor). Refer to chapter 3.3.1 for further information about adding electrolytic capacitors.</p>
	<p>Do not connect or disconnect motor during operation!</p> <p>Motor cable and motor inductivity might lead to voltage spikes when the motor is disconnected / connected while energized. These voltage spikes might exceed voltage limits of the driver MOSFETs and might permanently damage them. Therefore, always disconnect power supply before connecting / disconnecting the motor.</p>
	<p>Keep the power supply voltage below the upper limit of 52.5V!</p> <p>Otherwise the driver electronics will seriously be damaged! Especially, when the selected operating voltage is near the upper limit a regulated power supply is highly recommended.</p>
	<p>There is no reverse polarity protection!</p> <p>The module will short any reversed supply voltage due to internal diodes of the driver transistors.</p>

3.3.1 Adding an Electrolytic Capacitor

TRINAMIC recommends connecting an electrolytic capacitor of significant size to the power supply lines next to the TMCM-1311. As rule of thumb, around 1000µF of capacity should be added for 1A of module power supply input current.

The additional electrolytic capacitor

- serves for power stabilization (buffer) and filtering.
- reduces voltage spikes, which can occur in consequence of the combination of high inductance power supply wires and ceramic capacitors.
- limits the slew rate of the power supply voltage at the module. This is reasonable, because the low ESR (Equivalent Series Resistance) of ceramic-only filter capacitors may cause stability problems with some switching power supplies.

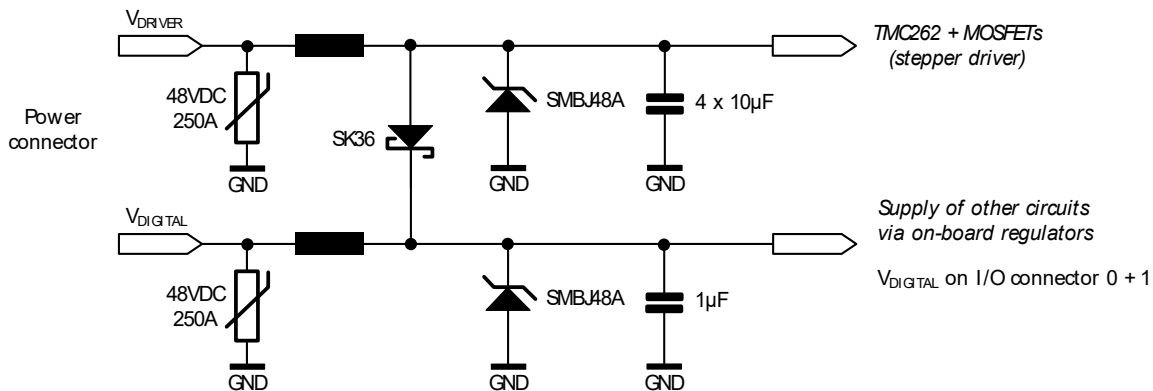

Figure 3.2 TMCM-1311 power supply concept

3.4 Communication

3.4.1 RS485

For remote control and communication with a host system the TMCM-1311 provides a two wire RS485 bus interface. The pins are shared with the CAN interface. Therefore, make sure the RS485 interface has been activated in software.

To select a modules' address, the TMCM-1311 is equipped with dip switches with digits from 1 to 4. Anyhow, the switches use the binary digit system. Thus, node addresses from 1 to 15 can be set.

THERE ARE TWO POSSIBILITIES FOR THE ADDRESS SETTING

- All DIP switches off: RS485 address is taken from the on-board non-volatile memory (EEPROM). Factory default value for the module address is 1.
- At least one DIP switch on: the 4 DIP switches define the RS485 address. The address is specified as binary 4bit value – DIP switches 1... 4 specify bit 1... 4 of the address



Figure 3.3 Dip switch for address selection

Note

- Per default, all dip switches are off and the module address taken from the EEPROM is 1. Per default, the host address is 2.
- Do not use equal addresses for the host and the TMCM-1311!

For proper operation, the following considerations should be taken into account when setting up an RS485 network:

1. **BUS STRUCTURE:**
The network topology should follow a bus structure as closely as possible. That is, the connection between each node and the bus itself should be as short as possible. Basically, it should be short compared to the length of the bus.

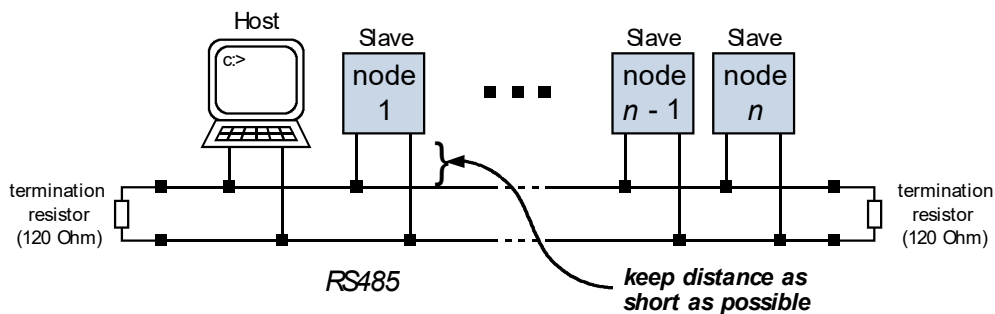

Figure 3.4 RS485 bus structure

2. **BUS TERMINATION:**
Especially for longer busses and/or multiple nodes connected to the bus and/or high communication speeds, the bus should be properly terminated at both ends. The TMCM-1311 does not integrate any termination resistor. Therefore, 120 Ω termination resistors at both ends of the bus have to be added externally.

3. *NUMBER OF NODES:*

The RS485 electrical interface standard (EIA-485) allows up to 32 nodes to be connected to a single bus. The bus transceiver used on the TMCM-1311 units (SN65HVD3082ED) has just 1/8th of the standard bus load and allows a maximum of 256 units to be connected to a single RS485 bus.

4. *NO FLOATING BUS LINES:*

Avoid floating bus lines while neither the host/master nor one of the slaves along the bus line is transmitting data (all bus nodes switched to receive mode). Floating bus lines may lead to communication errors. In order to ensure valid signals on the bus it is recommended to use a resistor network connecting both bus lines as well defined logic levels. In contrast to the termination resistors this network is normally required just once per bus. Certain RS485 interface converters available for PCs already include additional resistors (e.g. USB-2-485).

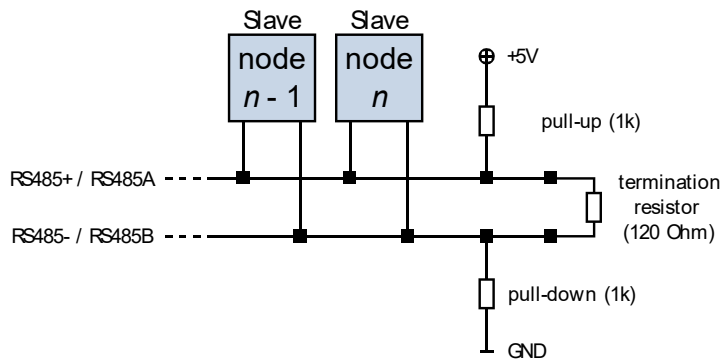

Figure 3.5 RS485 bus lines with resistor network

3.4.2 CAN

For remote control and communication with a host system the TMCM-1311 provides a CAN bus interface.

To select a modules' address, the TMCM-1311 is equipped with dip switches with digits from 1 to 4. Anyhow, the switches use the binary digit system. Thus, node addresses from 1 to 15 can be set.

THERE ARE TWO POSSIBILITIES FOR THE ADDRESS SETTING

- All DIP switches off: RS485 address is taken from the on-board non-volatile memory (EEPROM). Factory default value for the module address is 1.
- At least one DIP switch on: the 4 DIP switches define the CAN address. The address is specified as binary 4bit value – DIP switches 1... 4 specify bit 1... 4 of the address



Figure 3.6 Dip switch for address selection

Note

- Per default, all dip switches are off and the module address taken from the EEPROM is 1. Per default, the host address is 2.
- Do not use equal addresses for the host and the TMCM-1311!

For proper operation the following items should be taken into account when setting up a CAN network:

1. **BUS STRUCTURE**

The network topology should follow a bus structure as closely as possible. That is, the connection between each node and the bus itself should be as short as possible. Basically, it should be short compared to the length of the bus.

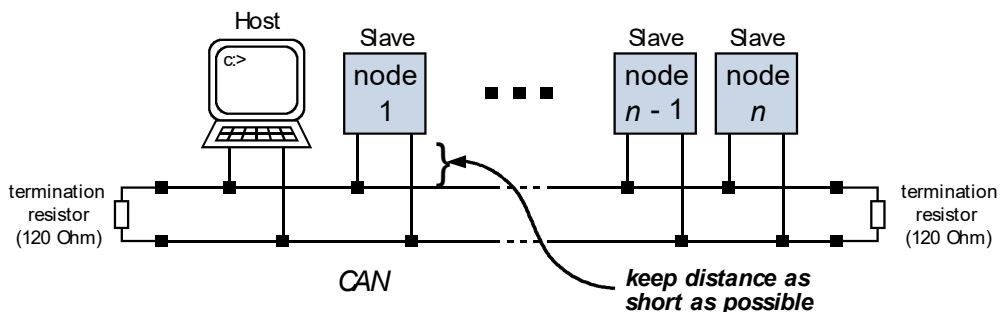

Figure 3.7 CAN bus structure

2. **BUS TERMINATION**

Especially for longer busses and/or multiple nodes connected to the bus and/or high communication speeds, the bus should be properly terminated at both ends. The TMCM-1311 does not integrate any termination resistor. Therefore, 120 Ω termination resistors at both ends of the bus have to be added externally.

3. **NUMBER OF NODES**

The bus transceiver used on the TMCM-1311 units (TJA1050T) supports at least 110 nodes under optimum conditions. In practice, the achievable number of nodes per CAN bus highly depends on the bus length (longer bus -> less nodes) and on the communication speed (higher speed -> less nodes).

3.4.3 USB

For remote control and communication with a host system the TMCM-1311 provides a USB 2.0 full-speed (12Mbit/s) interface. As soon as the USB-host is connected the module accepts commands via the USB interface. The TMCM-1311 supports USB *self powered operation* with external power supply via the power supply connector and USB *bus powered operation* without this external power supply.

USB BUS POWERED OPERATION

During USB bus powered operation only the core digital circuit parts - microcontroller and EEPROM - are operational. Motor movements are not possible. This mode has been implemented in order to enable configuration, parameter setting, read-out, firmware updates, etc. by connecting an USB cable between the module and an USB-host. No additional cabling or external devices (e.g. power supply) are required.

Please note that the module might draw current from the USB +5V bus supply even in USB self powered operation. This depends on the voltage level of this supply.

3.5 Inputs and Outputs

3.5.1 Encoder Input

The dedicated encoder connector offers support for the connection of an incremental encoder with a/b signals and optional n/index-channel. Encoders with +5V TTL, open-collector, or differential output signals can be connected directly. A +5V output - available at one connector pin - can be used for the encoder circuit supply. The on-board +5V switching voltage regulator has been designed in order to provide a maximum of 100mA for external circuits (shared with external encoder and reference switch circuit).

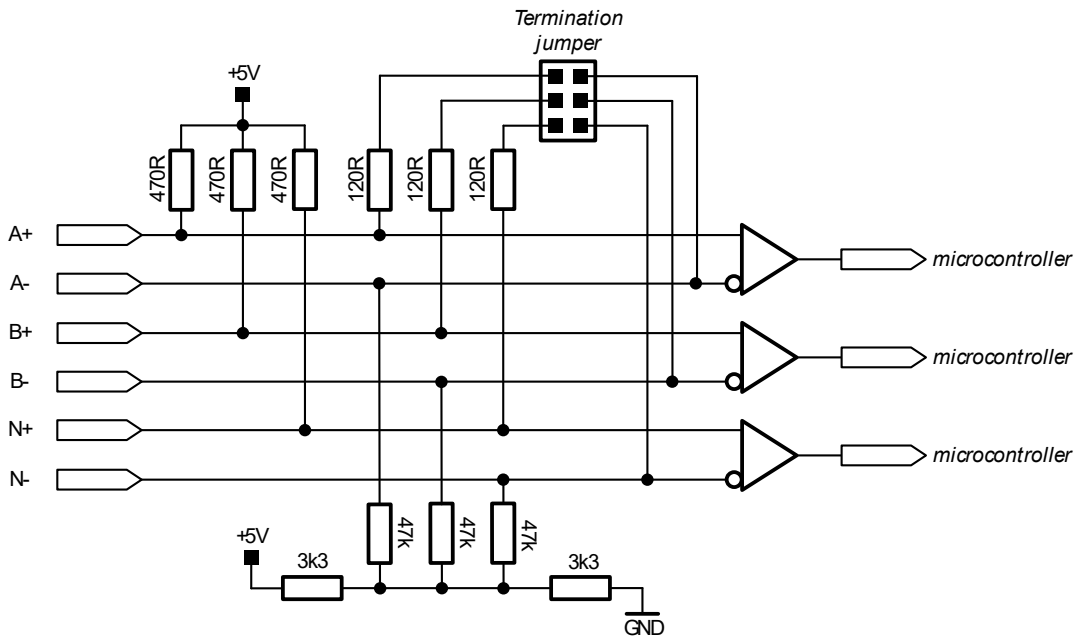

Figure 3.8 Encoder input circuit (simplified diagram)

3.5.2 Reference Switch Inputs

The reference switch connector provides two reference/limit switch inputs, REF_L and REF_R. Both inputs offer the same input circuit including voltage resistor dividers, limiting diodes against over- and under-voltage, and programmable 1k pull-ups to +5V. The programmable pull-ups can be switched on or off in software (both together).

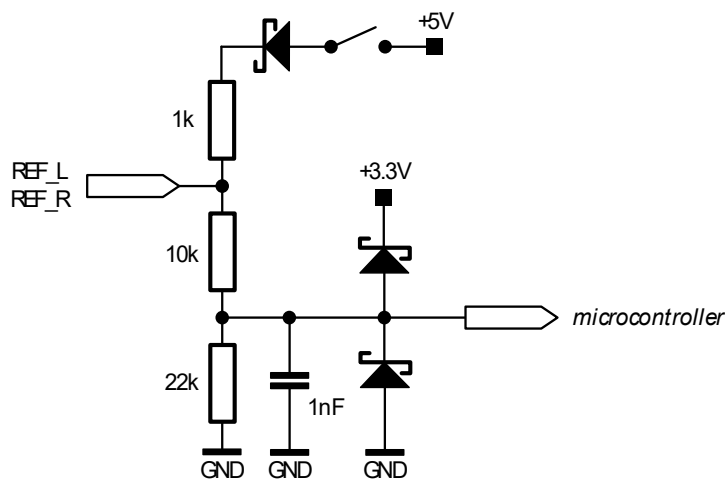

Figure 3.9 Reference switch input circuit (simplified diagram)

3.5.3 General Purpose Inputs

The TMCM-1311 has two I/O connectors with 8 inputs altogether including two dedicated analog inputs. All inputs offer the same basic input protection circuit, but digital and analog inputs have different input voltages: the digital inputs have been designed for +5V and +24V signal levels. The analog inputs have different input voltage dividers to support a full scale input voltage range of 0... +10V.

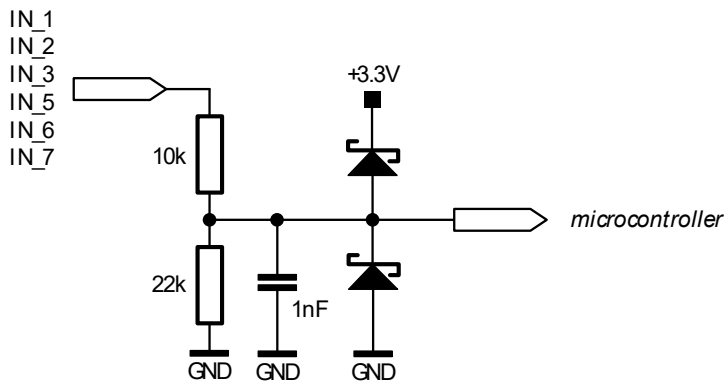

Figure 3.10 General purpose digital input circuit

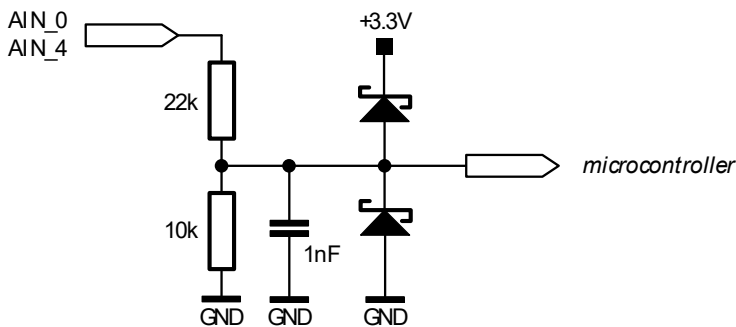

Figure 3.11 General purpose analog input circuit

The function of the inputs might differ depending on the firmware version.

3.5.4 General Purpose Outputs

The TMCM-1311 offers two I/O connectors with 8 outputs altogether. All outputs are open-drain outputs and a freewheeling diode (to $V_{DIGITAL}$) is already integrated. Six outputs are designed for currents up to 100mA and two outputs offer more powerful MOSFET driver transistors supporting currents up to 1A.

If the V_{CC} connection of the I/O connectors (connected internally to $V_{DIGITAL}$) is used for the *supply of substantial current* to any external circuit, make sure to connect $V_{DIGITAL}$ to V_{DRIVER} of the power supply connector.

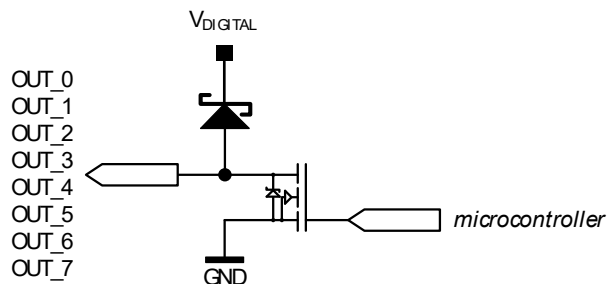

Figure 3.12 General purpose output (open-drain with freewheeling diode)

4 On-Board LEDs

The board offers two LEDs in order to indicate board status. The function of both LEDs is dependent on the firmware version. With standard TMCL firmware the green LED should be blinking during operation and the red LED should be off.

When there is no valid firmware programmed into the board or during firmware update (with boot loader active) the red and green LEDs are permanently on.



Figure 4.1 On-board LEDs

5 Operational Ratings

The operational ratings show the intended or the characteristic ranges and should be used as design values. ***In no case shall the maximum values be exceeded.***

Symbol	Parameter	Min	Typ	Max	Unit
V _{DRIVER}	Power supply voltage for driver	10	12..24..48	52.5	V
V _{DIGITAL}	Separate power supply voltage for controller (option, can be left unconnected)	V _{DRIVER}			V
V _{USB}	Power supply via USB connector		5		V
I _{USB}	Current withdrawn from USB supply when USB bus powered (no other supply connected)		tbd		mA
I _{COIL}	Motor coil current for sine wave peak (chopper regulated, adjustable via software)	0		4200	mA
I _{MC}	Continuous motor current (RMS)	0		3	A
I _S	Power supply current		<< 6x I _{COIL}	1.4x 6x I _{COIL}	A
T _{ENV@+24V}	Environmental temperature at maximum current (no forced cooling) with +24V supply voltage			50	°C
T _{ENV@+48V}	Environmental temperature at maximum current (no forced cooling) with +48V supply voltage			35	°C

Table 5.1 General operational ratings of the module

Symbol	Parameter	Min	Typ	Max	Unit
V _{REF_L/R}	Input voltage for reference switch inputs REF_L / REF_R	0		28	V
I _{REF_L/R_L}	Low level voltage for reference switch inputs REF_L / REF_R	0		1.1	V
I _{REF_L/R_H}	High level voltage for reference switch inputs REF_L / REF_R	2.9		28	V

Table 5.2 Operational ratings of the reference switch inputs

Symbol	Parameter	Min	Typ	Max	Unit
V _{OUT_0..7}	Voltage at open collector output	0		V _{DIGITAL}	V
I _{OUT_0/1/2/4/5/6}	Output sink current for OUT_0/1/2 and OUT_4/5/6			100	mA
I _{OUT_3/7}	Output sink current for OUT_3 and OUT_7			1	A
V _{IN_1/2/3/5/6/7}	Input voltage for general purpose digital inputs IN_1/2/3 and IN_5/6/7	0		28	V
V _{IN_1/2/3/5/6/7_L}	Low level voltage for general purpose digital inputs IN_1/2/3 and IN_5/6/7	0		1.1	V
V _{IN_1/2/3/5/6/7_H}	High level voltage for general purpose digital inputs IN_1/2/3 and IN_5/6/7	2.9		28	V
V _{AIN_0!4}	Full scale input voltage range for analog voltage inputs	0		10	V

Table 5.3 Operational ratings of the general purpose I/Os

6 Functional Description

The TMCM-1311 is a highly integrated single axis closed loop controller / driver module which can be controlled via USB, RS485, or CAN. Communication traffic is kept low since all time critical operations (e.g. ramp calculations) are performed on board. The preferred nominal supply voltage of the unit can be chosen out of 24V, 12V, and 48V DC. The module is designed for both, standalone operation and direct mode. Full remote control of the device with feedback is possible. The firmware of the module can be updated via the USB interface.

In Figure 6.1 the main parts of the TMCM-1311 are shown:

- the microprocessor, which runs the TMCL operating system (connected to TMCL memory)
- the power driver with stallGuard2 and its energy efficient coolStep feature
- the MOSFET driver stage
- Encoder interface
- USB, CAN and RS485 transceivers
- On-board switching and linear voltage regulators for supply of on-board digital circuits

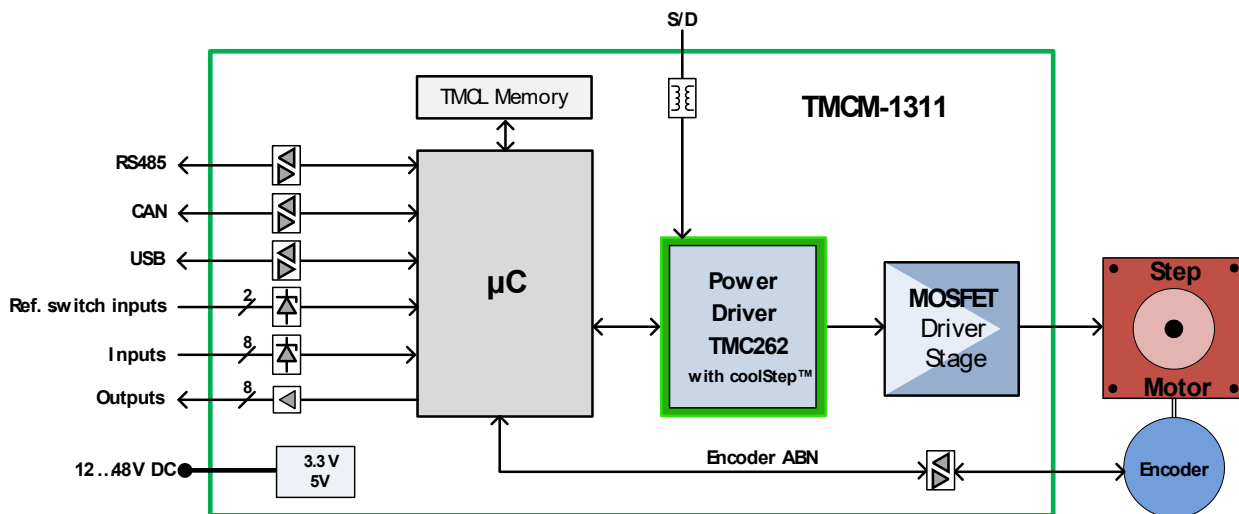

Figure 6.1 Main parts of TMCM-1311

The TMCM-1311 comes with the PC based software development environment TMCL-IDE for the TRINAMIC Motion Control Language (TMCL). Using predefined TMCL high level commands like *move to position* a rapid and fast development of motion control applications is guaranteed.

Please refer to the TMCM-1311 Firmware Manual for more information about TMCL commands.

7 Life Support Policy

TRINAMIC Motion Control GmbH & Co. KG does not authorize or warrant any of its products for use in life support systems, without the specific written consent of TRINAMIC Motion Control GmbH & Co. KG.

Life support systems are equipment intended to support or sustain life, and whose failure to perform, when properly used in accordance with instructions provided, can be reasonably expected to result in personal injury or death.

© TRINAMIC Motion Control GmbH & Co. KG 2013

Information given in this data sheet is believed to be accurate and reliable. However neither responsibility is assumed for the consequences of its use nor for any infringement of patents or other rights of third parties, which may result from its use.

Specifications are subject to change without notice.

All trademarks used are property of their respective owners.



8 Revision History

8.1 Document Revision

Version	Date	Author	Description
0.90	2012-OCT-25	GE	Preliminary version
1.00	2012-DEC-05	SD	First complete version
1.10	2013-MAY-23	GE	Adapted to latest hardware version V1.2
1.11	2013-JUL-03	SD	Information about dip switch added. New photo. Changes related to the design.
1.12	2013-JUL-05	SD	New front picture

Table 8.1 Document revision

8.2 Hardware Revision

Version	Date	Description
TMCM-1311_V10	2012-JUL-27	Initial version
TMCM-1311_V11	2013-JAN-14	Minor corrections and modifications: <ul style="list-style-type: none"> - USB circuit corrected - Current measurement option added to motor driver output signals
TMCM-1311_V12	2013-APR-10	Several corrections and modifications: <ul style="list-style-type: none"> - Additional supply input filters and enhanced protection circuit - Stepper motor driver stage output filter added - Revised ground / shield concept. Enclosure connected to shield instead of system ground - Option for supply current measurement added

Table 8.2 Hardware revision

9 References

- [TMCL-IDE] TMCL-IDE User Manual
see <http://www.trinamic.com>
- [TMCM-1311] TMCM-1311 Hardware Manual
see <http://www.trinamic.com>