

Specifications

Electrical

Supply Voltage: 24, 120 & 240VAC ±10%

Power: 2VA

Inputs: Switch Closure or Probe (Conductivity)

Input Sensitivity: 3K - 1.5MΩ

Pick-up & Drop-out Delays: 1 second

Max. Open Circuit Voltage: 5 volts AC

Max. Source Current: 0.1 milliamp AC

Output Rating @ 25°C:

5 Amps or 100VA per contact

10 Amps total

250VAC maximum contact rating

10,000,000 Mechanical Cycles

Physical

Mounting: Din Rail mount

Termination: Touch safe screw terminals, with lift mechanism, #12 AWG max. for supply and relay contacts, #16 AWG max. for intrinsically safe inputs.

Weight: 10 Oz.

Ambient Temperatures

Operating: 0°C to 50°C

Storage: -40°C to 85°C



Ordering Information

IS 4 R - 120A - R - 10K

R-K Model

Number of Channels

- 1 - 1 I/O
- 2 - 2 I/O
- 3 - 3 I/O
- 4 - 4 I/O

Mounting Options

- R - DIN Rail
- S - Surface

Sensitivity

- 10K - 10,000 Ohms
- 50K - 50,000 Ohms
- 100K - 100,000 Ohms
- - Other Options

Relay Operation

- R - Relay

Operating Voltage

- 24A -24VAC
- 120A -120VAC
- 240A -240VAC

- 1, 2, 3, or 4 Channels
- Shorted Input Sensing
- Open Input Sensing
- Outputs Isolated from Supply
- Contact or Probe Inputs
- Conductivity or Resistance Inputs
- Output and Input LED Indication
- Independent Operation
- Pluggable Terminal Blocks
- Din or Surface Mount
- 24 to 240VAC Supply

Connections

Non-Hazardous Location

AC Supply Voltage

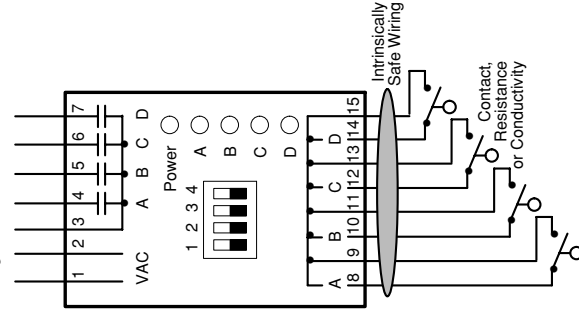

Dimensions

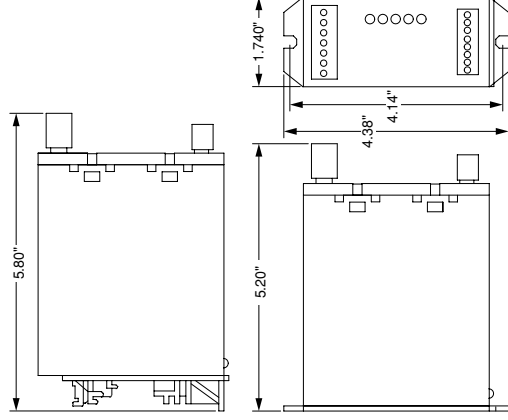

UL913
Class I, Division 1
Groups A, B, C & D

Operation

Independent Channel Relay

Supply voltage must be applied to the IS-R relay during operation. The IS-R can have 1, 2, 3 or 4 channels. When IS input #1 closes its LED changes and #1 output contact closes. When IS input #1 opens #1 output contact opens. Each channel operates independent of the other channels. LED indicators are:

Red - When the IS input is open or high contact are closed

Flashes - During transition delay

A green LED indicates when supply voltage has been applied to the IS-R.



Installation of Relays with Intrinsic Safe Inputs

Installation of Relay Module with Intrinsically Safe Inputs
 Installation of these relays should only be performed by personnel experienced with intrinsically safe devices. Proper wiring practices must be strictly adhered to in order to prevent injury to personnel and property damage due to explosion or fire. **IMPORTANT: BEFORE PROCEEDING TO INSTALL THE DEVICE, READ AND THOROUGHLY UNDERSTAND THESE INSTRUCTIONS.**
 When installed according to the following instructions the Relay Module provide circuits for use in Class I, Division 1, Groups A, B, C, and D. The device must be mounted in a suitable enclosure which is tool accessible and is situated in a non hazardous area where an explosive atmosphere will not exist at any time.

WIRING:

1. Associated apparatus must be installed in an enclosure suitable for the application in accordance with the National Electrical Code (ANSI/NFPA 70) for installation in the United States, the Canadian Electrical Code for installations in Canada, or other local codes, as applicable.
2. Where multiple circuits extend from the same piece of associated apparatus, they must be installed in separate cables or in one cable having suitable insulation. Refer to Article 504.30(B0) of the National Electrical Code (ANSI/NFPA 70) and Instrument Society of America Recommended Practice ISA RP12.6 for installing intrinsically safe equipment.
3. Intrinsically safe circuits must be wired and separated in accordance with Article 504.20 of the National Electrical Code (ANSI/NFPA 70) or other local codes, as applicable.
4. Electrical equipment connected to the non intrinsically safe side should not use or be capable of generating more than 250 volts with respect to earth.
5. Intrinsically safe wiring connecting to the relay must be kept separate from non-intrinsically safe wiring by means of physical barriers and wiring tie down devices to insure no contact.
6. Cable capacitance plus intrinsically safe equipment capacitance must be less than the marked capacitance (Ca) shown on any barrier used. The same applies for inductance. We recommend the use of type THHN wire without splices. In no case should the capacitance or inductance exceed the specified limits. If the characteristics of your wire are unknown the following values may be used.
 CAPACITANCE: 60 pf / ft INDUCTANCE: 0.20 µh / ft
7. Selected intrinsically safe equipment must be third party listed as intrinsically safe for the application, and have intrinsically safe entity parameters conforming with Table 1 below. The entity parameters have been assigned based on the worse case combination of all intrinsically safe circuits.

Table 1:

I.S. Equipment	Associated Apparatus
$V_{max} \text{ (or } U_i) \geq V_{oc} \text{ or } V_t \text{ (or } U_o)$	
$I_{max} \text{ (or } I_i) \geq I_{sc} \text{ or } I_t \text{ (or } I_o)$	
$P_{max}, P_i \geq P_o$	
$C_i + C_{cable} \leq C_a \text{ (or } C_o)$	
$L_i + L_{cable} \leq L_a \text{ (or } L_o)$	

Entity parameters:
 $V_{oc} = 16.8 \text{ Volts}$
 $I_{sc} = 3.3 \text{ mA}$
 $C_a = 0.312 \mu\text{f}$
 $L_a = 100 \text{ mH}$
 $V_{oc} \leq V_{max}$
 $I_{sc} \leq I_{max}$
 $C_a \geq C_i + C_{cable}$
 $L_a \geq L_i + L_{cable}$

NON-HAZARDOUS LOCATION

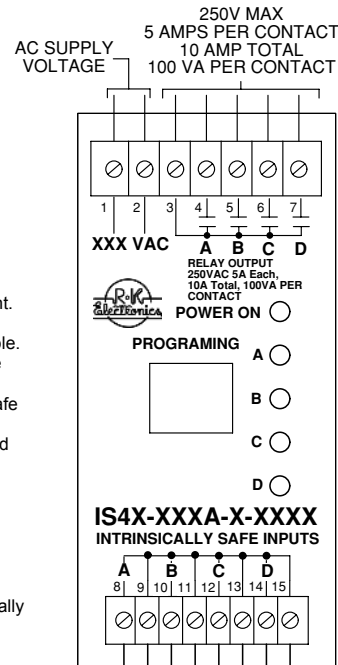

NOTE:
 LB = LEAD BREAKAGE MONITORING
 SC = SHORT CIRCUIT MONITORING
 R1 = 10K
 R2 = 400 OHM TO 2K OHM
 R3 = 3 MEG. OHM
 R4 = 1 MEG. MAX

**HAZARDOUS LOCATION
 CLASS I, GROUPS A,B,C,D**

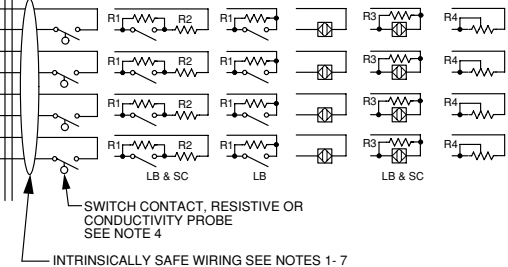

REF. DRAWING(S)	REV.	DATE	CAR/PROJECT #	DESCRIPTION	CONTROL DRAWING			
<h2 style="text-align: center;">R-K Electronics, Inc.</h2> <p style="text-align: center;">CINCINNATI, OHIO 45249</p>					SCALE: NONE	UPDATED BY	REDESIGNED BY	A-6888-4
					SIMILAR TO:	DRAWN BY	DESIGNED BY	
					QUOTE #:	O.S.	D.P.	
					DRAWING DATE: 01/17/06			