

PART NUMBER	REVISION	DESCRIPTION	FEED TYPE
2151113-1	M	FINE CRIMP HEIGHT ADJUST	MECHANICAL
2151113-2	M	FINE CRIMP HEIGHT ADJUST	PNEUMATIC
7-2151113-1	M	MECHANICAL AND CRIMP TOOLING KIT	MECHANICAL
7-2151113-2	M	PNEUMATIC AND CRIMP TOOLING KIT	PNEUMATIC
7-2151113-7	M	CRIMP TOOLING KIT	-

ATLANTIC VERSION TERMINATOR INTERFACE ADAPTER

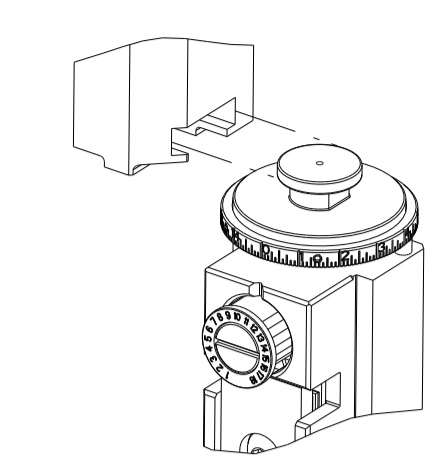

APPLICATOR DATA		
CRIMP	SIZE	TYPE
WIRE	1.78 mm [.070]	F
INSUL	2.60 mm [.102]	F

APPLICATOR INSTRUCTIONS 408-35042

TERMINAL DATA: TE TERMINAL		TE CRIMP SPECIFICATION	
TERMINAL NAME: ECONOMY POWER(EP) CONN.REC CONT			
WIRE STRIP LENGTH		INSULATION DIAMETER RANGE	
2.70-3.30 mm [.106-.130 IN]		Ø1.70-3.00 mm [.067-.118 IN]	
TERMINAL APPLICATION SPECIFICATION	(A)114-5253	-	-
TERMINALS APPLIED			
TE TERMINAL	TE TERMINAL	TE TERMINAL	TE TERMINAL
1123721-1	1123721-2	647662-1	
1123721-4	3-1123721-1		

TERMINAL DATA: TE TERMINAL		TE CRIMP SPECIFICATION	
TERMINAL NAME: ECONOMY POWER(EP) CONN.REC CONT			
WIRE STRIP LENGTH		INSULATION DIAMETER RANGE	
2.69-3.30 mm [.106-.130 IN]		Ø1.70-2.90 mm [.067-.114 IN]	
TERMINAL APPLICATION SPECIFICATION	(B)114-13265	-	-
TERMINALS APPLIED			
TE TERMINAL	TE TERMINAL	TE TERMINAL	TE TERMINAL
1744144-1	1744144-2	1744144-3	

TERMINAL DATA: TE TERMINAL		TE CRIMP SPECIFICATION	
TERMINAL NAME: ECONOMY POWER(EP) CONN.REC CONT			
WIRE STRIP LENGTH		INSULATION DIAMETER RANGE	
2.70-3.30 mm [.106-.130 IN]		Ø1.80-2.80 mm [.071-.110 IN]	
TERMINAL APPLICATION SPECIFICATION	(C)114-5303	-	-
TERMINALS APPLIED			
TE TERMINAL	TE TERMINAL	TE TERMINAL	TE TERMINAL
1123721-3			

WIRE SIZE	CRIMP HEIGHT mm [INCH]	CRIMP HEIGHT REFERENCE SETTING
0.75-0.89mm (#18)	1.15+/-0.05 [.045+/- .002]	4.6
0.5-0.56mm (#20)	1.10+/-0.05 [.043+/- .002]	4.9
0.3-0.35mm (#22)	1.00+/-0.05 [.039+/- .002]	6.0

WIRE SIZE	CRIMP HEIGHT mm [INCH]	CRIMP HEIGHT REFERENCE SETTING
0.75-0.89mm (#18)	1.15+/-0.05 [.045+/- .002]	4.6
0.5-0.56mm (#20)	1.10+/-0.05 [.043+/- .002]	4.9
0.3-0.35mm (#22)	1.00+/-0.05 [.039+/- .002]	6.0

WIRE SIZE	CRIMP HEIGHT mm [INCH]	CRIMP HEIGHT REFERENCE SETTING
1.25-1.37mm (#16)	1.34+/-0.05 [.053+/- .002]	2.7
0.75-0.86mm (#18)	1.15+/-0.05 [.045+/- .002]	4.9
0.53-0.66mm (#20)	1.10+/-0.05 [.043+/- .002]	6.0

- 1 RECOMMENDED SPARE PARTS
- 2 REFER TO SUPPLIED INSTRUCTION SHEET FOR CLEANING, LUBRICATION & STORAGE OF APPLICATOR.
- 3 APPLY PART NUMBER 2-23419-6 LOCTITE TO THREADS OF ITEM 242.
- 4 CRIMP HEIGHT REFERENCE SETTING WAS THE SETTING USED WHEN THE APPLICATOR WAS QUALIFIED AT THE FACTORY. ADJUSTMENT MAY BE NECESSARY WHEN RUNNING APPLICATOR IN THE FIELD.
- 5. UNLESS SPECIFIED OTHERWISE TORQUE VALUES SHALL BE USED PER DOCUMENT, 101-35000.

\*WARNING  
ON INSTALLATION, SET WIRE DISC TO CRIMP HEIGHT REFERENCE SETTING FOR LARGEST WIRE SIZE. CRIMP HEIGHT REFERENCE SETTINGS GREATER THAN THE VALUE SHOWN MAY CAUSE DAMAGE TO THE CRIMP TOOLING. REFER TO THE INSTRUCTION SHEET FOR PROPER SETUP AND ADJUSTMENTS.

ATLANTIC VERSION  
Shown on sheets 1 of 4 & 2 of 4  
(Pacific version shown on sheets 3 of 4 & 4 of 4)

LOC	DIST	REVISIONS			
P	LTN	DESCRIPTION	DATE	OWN	APVD
L		ECR-19-010606	08JUL2019	FJ	TE
L1		ECR-20-002802	26FEB2020	RK	TE
L2		ECR-22-149376	15AUG2022	FJ	YY
M		ECR-23-175794	18MAY2023	FZ	JAH

-	1	1	1	1	2119791-9	DEPRESSOR, WIRE	286
-	1	-	1	-	2119641-1	FEED CAM, AIR FEED	248
-	1	1	1	1	2119082-9	CAM, SNAIL, INSULATION ADJUSTMENT	244
-	1	1	1	1	2079764-1	WASHER, WAVE SPRING, CREST-TO-CREST	243
-	1	1	1	1	2119083-1	RETAINER, INSULATION DIAL	242
-	1	1	1	1	7-18023-7	SCR, SKT HD CAP M3 X 4.0	241
-	-	1	-	1	2119580-1	MECHANICAL FEED ASSEMBLY	239
-	1	-	1	-	2844940-1	AIR FEED MODULE	238
-	REF	REF	REF	REF	994970-2	COUNTER, MAGNETIC	164
-	1	1	1	1	2844908-1	SCREW, LOCKING	99
-	1	1	1	1	2844907-1	POST, LOCKING	98
-	1	1	1	1	455888-4	SPACER, CRIMPER	82
-	1	1	1	1	1803607-3	DOCUMENTATION PACKAGE	71
-	1	1	1	1	2119943-1	WASHER, SPACER	69
-	1	1	1	1	2119740-1	TAG, IDENTIFICATION	67
-	2	2	2	2	2168078-1	SCREW, DRIVE, RH, RoHS, 2 x .188	66
-	1	1	1	1	2168083-2	SCR, SKT HD CAP, RoHS, M4 X 8.0	60
-	1	1	1	1	5-18022-5	SCR, HEX HD CAP, M4 X 6.0	59
-	1	1	1	1	1338685-1	PAWL, FEED	56
-	4	4	4	4	2168083-3	SCR, SKT HD CAP, RoHS, M4 X 12.0	54
-	2	2	2	2	1-2168083-0	SCR, SKT HD CAP, RoHS, M4 X 10	53
-	1	1	1	1	1803382-2	HOLD DOWN, SPRING LOADED	50
-	1	2	1	2	18023-9	SCR, SKT HD CAP M4 X 6.0	49
-	-	1	-	1	2119652-1	FEED CAM, PRE FEED	48
-	-	1	-	1	2119653-1	FEED CAM, POST FEED	47
-	1	1	1	1	1803583-9	APPLICATOR BASIC ASSEMBLY, SF	46
-	1	1	1	1	1803515-1	RAM ASSEMBLY, SF ATLANTIC	44
-	1	1	1	1	1803602-1	SCR, BHSC, RoHS (M8 X 25)	41
-	1	1	1	1	1752356-3	SUPPORT, TERMINAL	34
-	2	2	2	2	2079383-5	SCR, BHSC, RoHS (M4 X 20)	33
-	2	2	2	2	2-2844962-4	SPACER, CYLINDRICAL, STRIP GUIDE	30
-	1	1	1	1	2844992-1	ASSEMBLY, STRIP GUIDE	29
-	1	1	1	1	455888-6	SPACER, CRIMPER	28
-	1	1	1	1	1320928-2	STRIP GUIDE	24
-	1	1	1	1	2168083-2	SCR, SKT HD CAP, RoHS, M4 X 8.0	21
-	2	2	2	2	1-18028-2	WASHER, FLAT, REG M4	20
-	1	1	1	1	2119533-1	STRIPPER, SIDE FEED	19
-	1	1	1	1	2119806-1	INSERT, SHEAR	13
-	1	1	1	1	3-22280-3	SPRING, COMPRESSION	12
-	1	1	1	1	1-356885-4	STOP, SHEAR	11
-	1	1	1	1	2119805-1	SHEAR HOLDER, FRONT	10
-	1	1	1	1	1803095-3	FLOATING SHEAR, FRONT	9
-	1	2	2	1	1333203-4	ANVIL, COMBINATION	8
-	-	-	-	-	-	-	7
-	-	-	-	-	-	-	6
-	1	1	1	1	1-2119757-2	DEPRESSOR, SHEAR	5
-	1	1	1	1	2-238011-5	BLOCK, CRIMPER SPACER	4
-	1	2	2	1	1-1803260-3	CRIMPER, INSULATION F PREMIUM	3
-	1	1	1	1	455888-5	SPACER, CRIMPER	2
-	1	2	2	1	2-456404-5	CRIMPER, WIRE PREMIUM	1

DIMENSIONS:		TOLERANCES UNLESS OTHERWISE SPECIFIED:		OWN	CHK	DATE	NAME	SIZE	CAGE CODE	DRAWING NO	RESTRICTED TO
mm	0 PLC ±	1 PLC ±	2 PLC ±	3 PLC ±	4 PLC ±	ANGLES FINISH					
MATERIAL		FINISH		APVD	CHK	DATE	NAME	SIZE	CAGE CODE	DRAWING NO	RESTRICTED TO
				J. CRUZ	S. XI	28SEP2011	H. HUANG	A1	00779	2151113	
				Customer Accessible Production Drawing		SCALE	SHEET	1	OF	4	REV
						1:2					M

LOC	DIST	REVISIONS			
P	LTN	DESCRIPTION	DATE	OWN	APVD
A	66	SEE SHEET 1	-	-	-

# FEED TYPE MECHANICAL

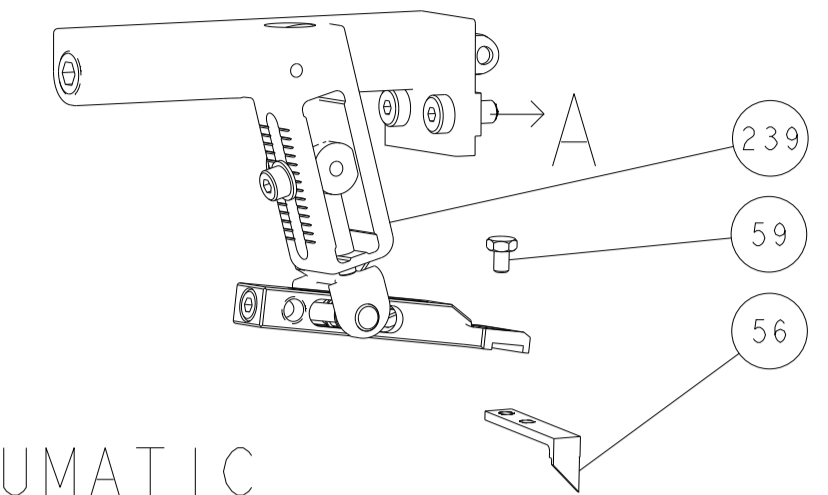

## PNEUMATIC

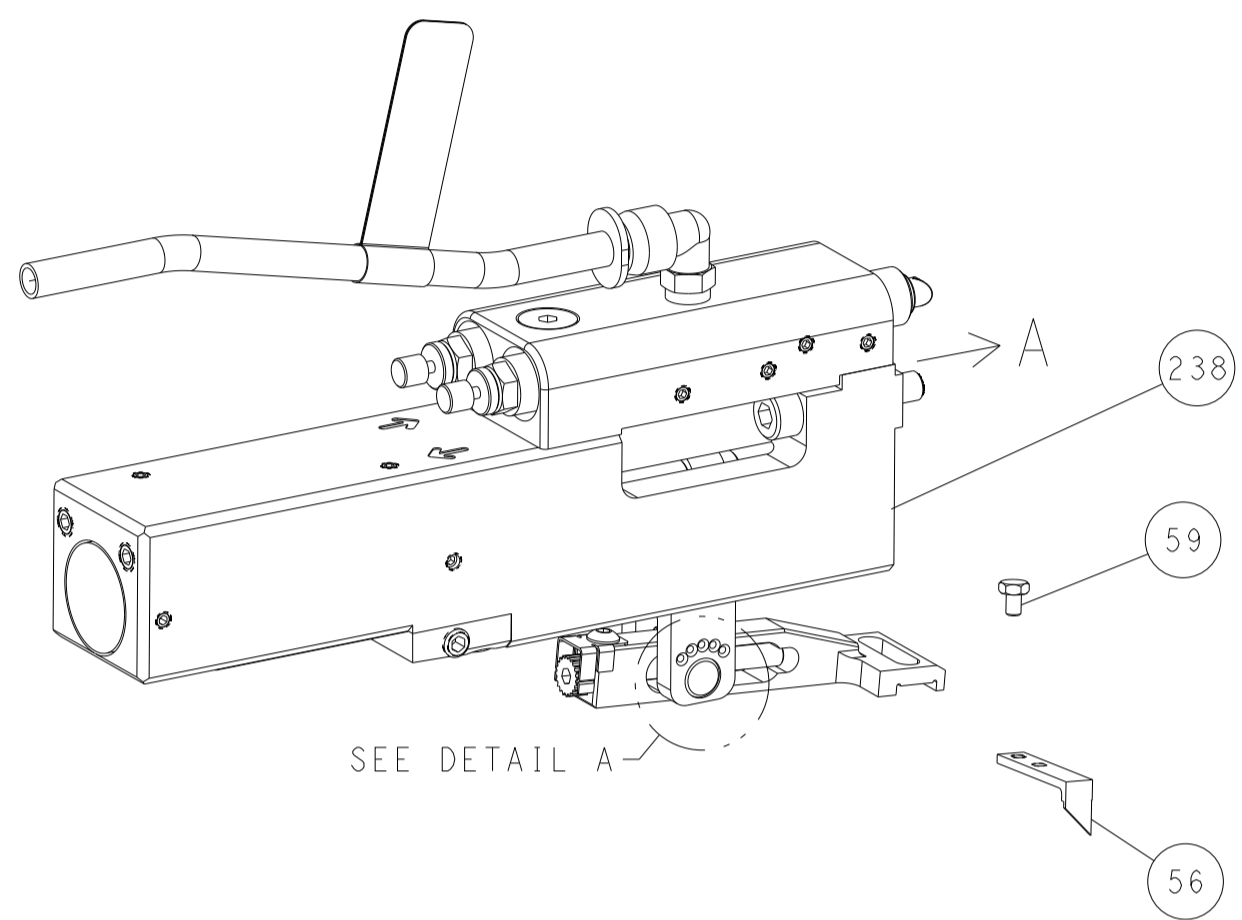

## FEED SPRING SETTING POSITION (SHOWN FROM REAR SIDE)



DETAIL A

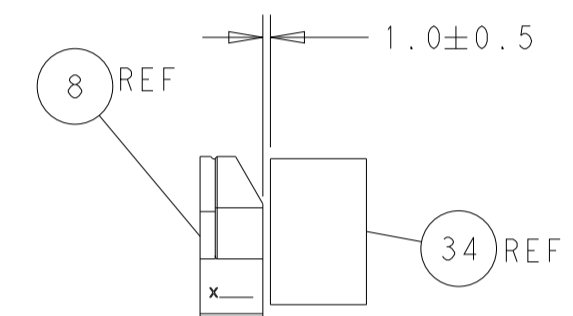
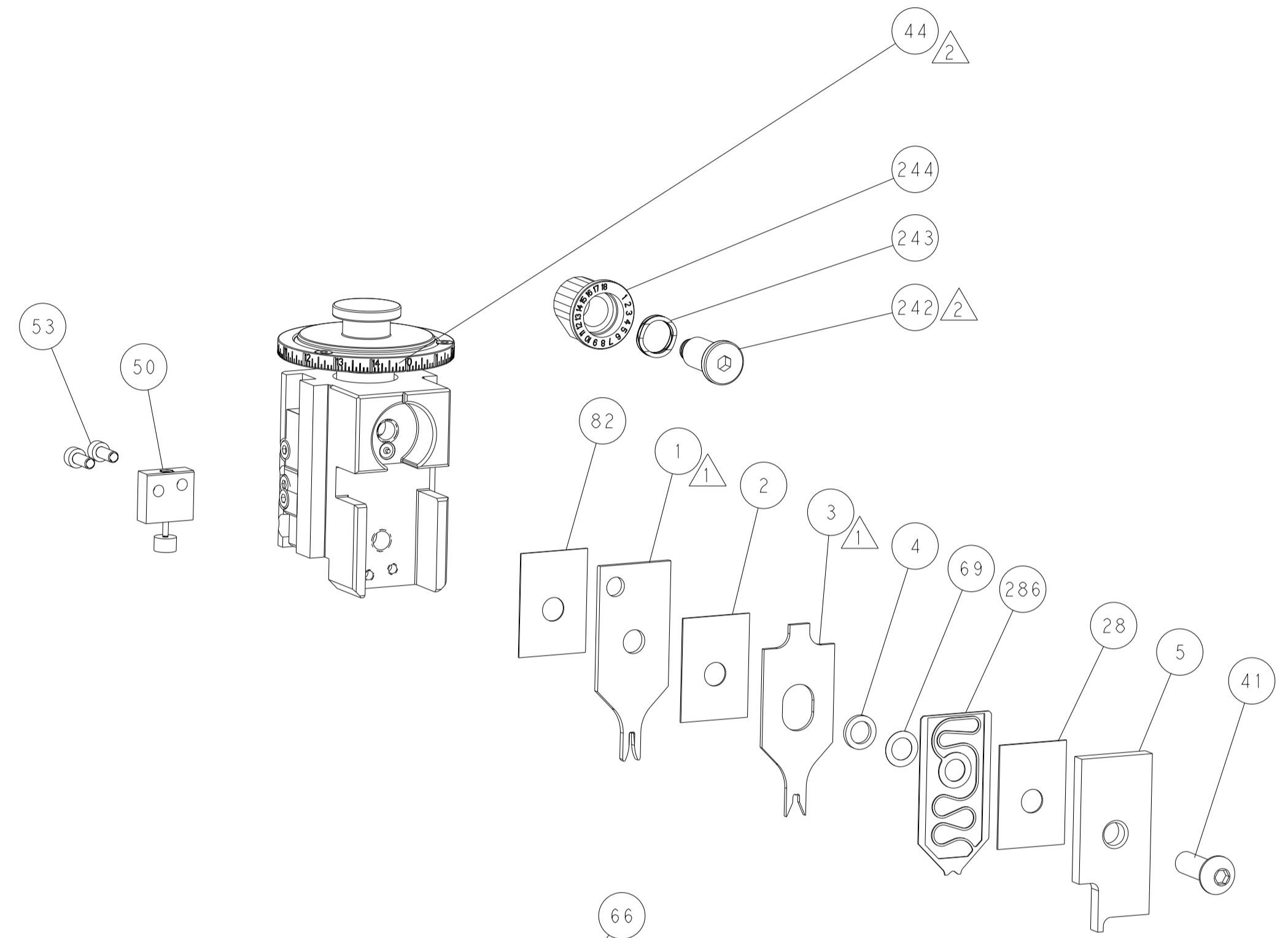

TERMINAL SUPPORT LOCATION

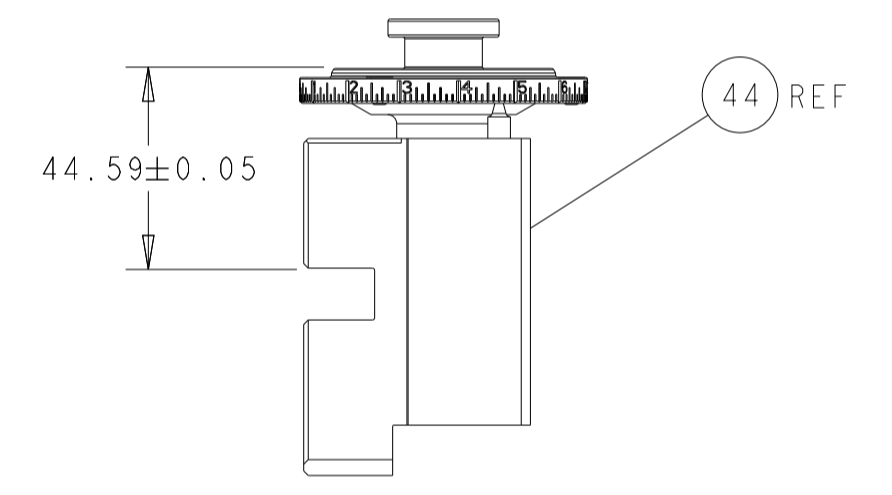

RAM SET-UP

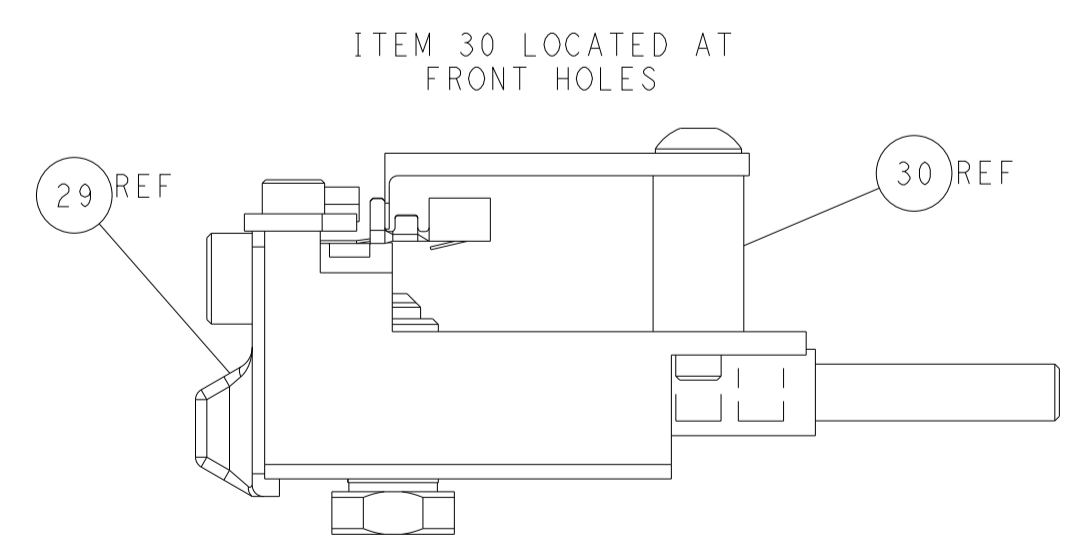
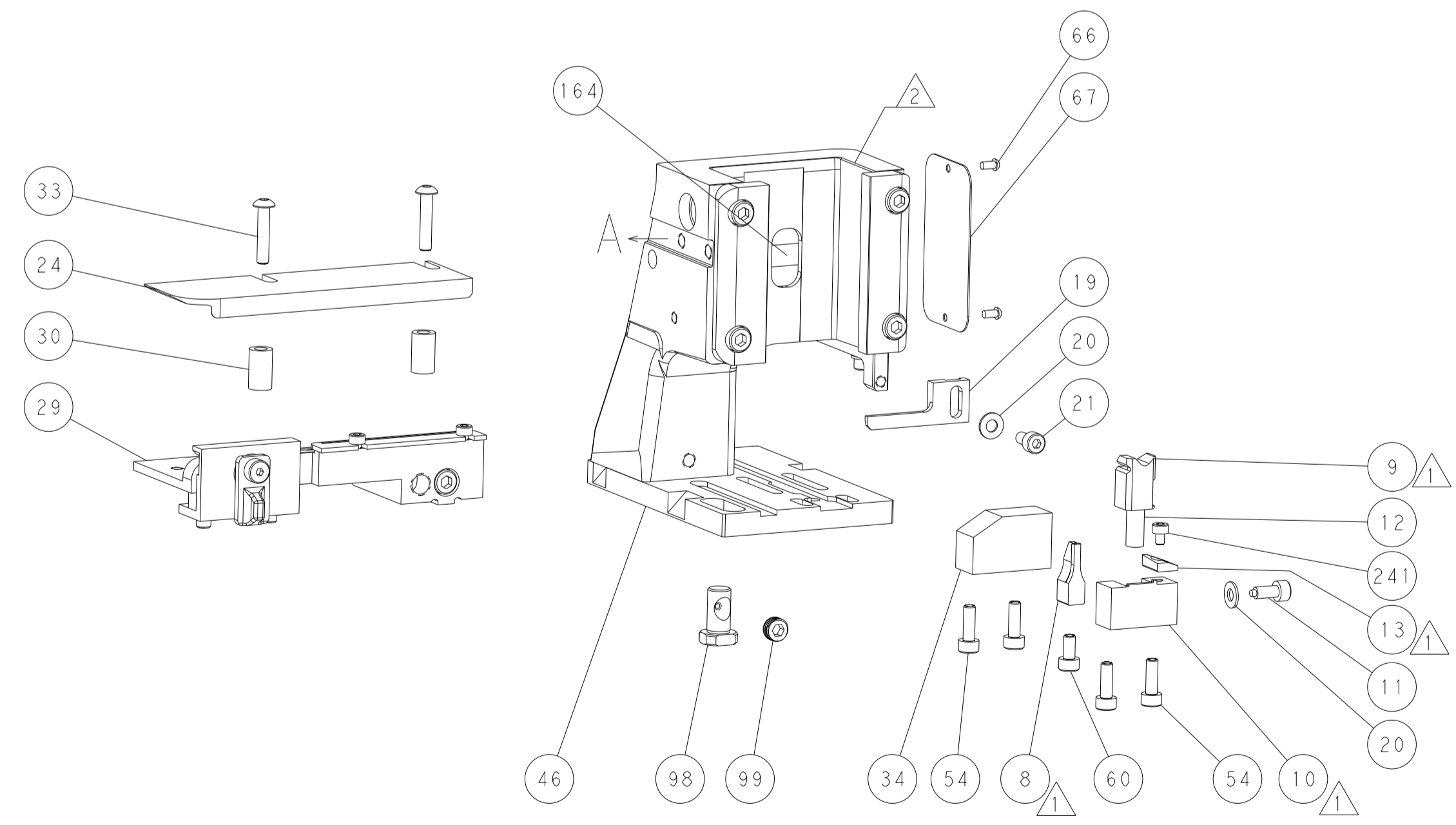

ITEM 30 LOCATED AT FRONT HOLES

# CAM POSITIONS

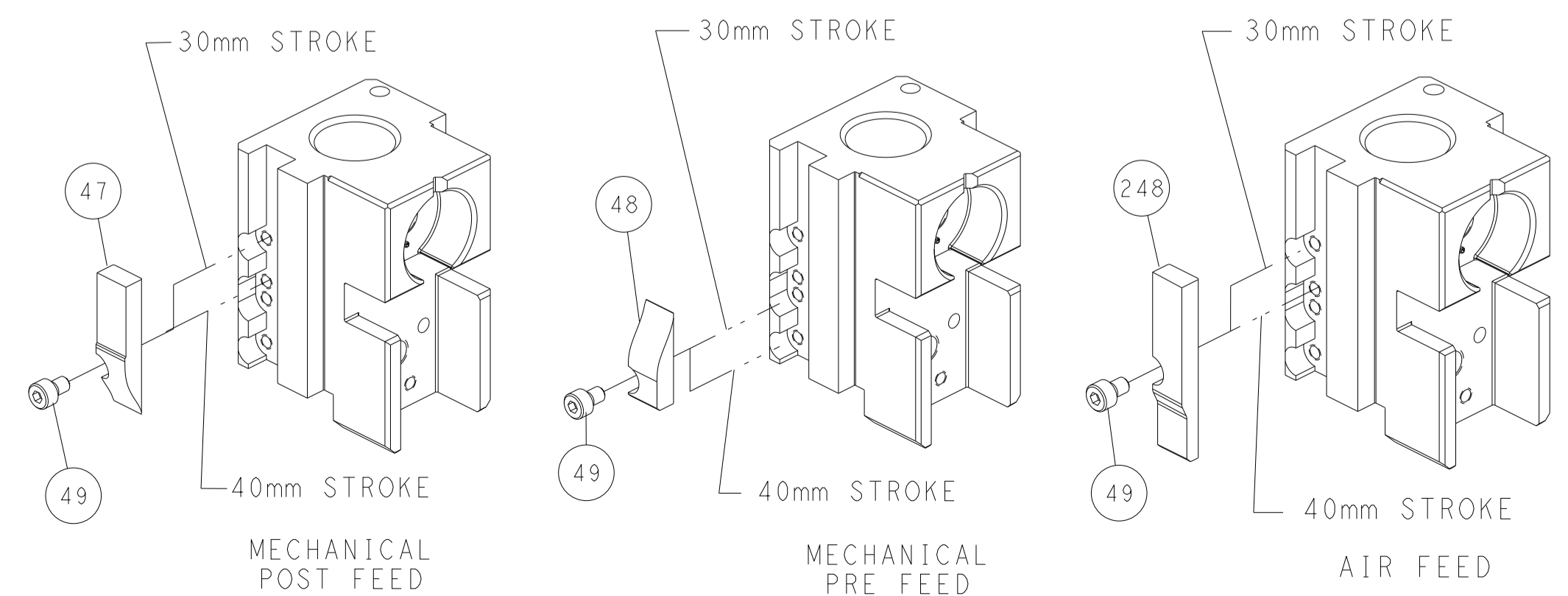

**ATLANTIC VERSION**  
 Shown on sheets 1 of 4 & 2 of 4  
 (Pacific version shown on sheets 3 of 4 & 4 of 4)

DIMENSIONS:		TOLERANCES UNLESS OTHERWISE SPECIFIED:		DWG		REV	
mm	0 PLC	±		H. HUANG	28SEP2011	STE TE Connectivity	
	1 PLC	±		S. XI	28SEP2011	Harrisburg, PA 17105-3608	
	2 PLC	±		J. CRUZ	28SEP2011	NAME	
	3 PLC	±				Ocean Side Feed	
	4 PLC	±				Applicator	
	ANGLES	±				SIZE	CAGE CODE
	FINISH	±				A1	00779
MATERIAL						DRAWING NO	©=2151113
						RESTRICTED TO	
						Customer Accessible Production Drawing	SCALE
						1:2	SHEET 2 OF 4
							REV M

PART NUMBER	REVISION	DESCRIPTION	FEED TYPE
2-2151113-1	M	FINE CRIMP HEIGHT ADJUST	MECHANICAL
2-2151113-2	M	FINE CRIMP HEIGHT ADJUST	PNEUMATIC
7-2151113-7	M	CRIMP TOOLING KIT	-

PACIFIC VERSION TERMINATOR  
INTERFACE ADAPTER

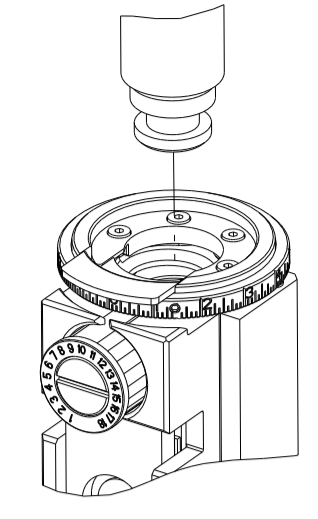

APPLICATOR DATA		
CRIMP	SIZE	TYPE
WIRE	1.78 mm [.070]	F
INSUL	2.60 mm [.102]	F
APPLICATOR INSTRUCTIONS 408-35042		

TERMINAL DATA: TE TERMINAL		TE CRIMP SPECIFICATION	
TERMINAL NAME: ECONOMY POWER(EP) CONN.REC CONT			
WIRE STRIP LENGTH		INSULATION DIAMETER RANGE	
2.70-3.30 mm [.106-.130 IN]		Ø1.70-3.00 mm [.067-.118 IN]	
TERMINAL APPLICATION SPECIFICATION	(A)114-5253	-	-
TERMINALS APPLIED			
TE TERMINAL	TE TERMINAL	TE TERMINAL	TE TERMINAL
1123721-1	1123721-2	1123721-3	647662-1
1123721-4	3-1123721-1		

TERMINAL DATA: TE TERMINAL		TE CRIMP SPECIFICATION	
TERMINAL NAME: ECONOMY POWER(EP) CONN.REC CONT			
WIRE STRIP LENGTH		INSULATION DIAMETER RANGE	
2.69-3.30 mm [.106-.130 IN]		Ø1.70-2.90 mm [.067-.114 IN]	
TERMINAL APPLICATION SPECIFICATION	(B)114-13265	-	-
TERMINALS APPLIED			
TE TERMINAL	TE TERMINAL	TE TERMINAL	TE TERMINAL
1744144-1	1744144-2	1744144-3	

TERMINAL DATA: TE TERMINAL		TE CRIMP SPECIFICATION	
TERMINAL NAME: ECONOMY POWER(EP) CONN.REC CONT			
WIRE STRIP LENGTH		INSULATION DIAMETER RANGE	
2.70-3.30 mm [.106-.130 IN]		Ø1.80-2.80 mm [.071-.110 IN]	
TERMINAL APPLICATION SPECIFICATION	(C)114-5303	-	-
TERMINALS APPLIED			
TE TERMINAL	TE TERMINAL	TE TERMINAL	TE TERMINAL
1123721-3			

WIRE SIZE	CRIMP HEIGHT mm [INCH]	CRIMP HEIGHT REFERENCE SETTING
0.75-0.89mm (#18)	1.15+/-0.05 [.045+/-0.002]	4.6
0.5-0.56mm (#20)	1.10+/-0.05 [.043+/-0.002]	4.9
0.3-0.35mm (#22)	1.00+/-0.05 [.039+/-0.002]	6.0

WIRE SIZE	CRIMP HEIGHT mm [INCH]	CRIMP HEIGHT REFERENCE SETTING
0.75-0.89mm (#18)	1.15+/-0.05 [.045+/-0.002]	4.6
0.5-0.56mm (#20)	1.10+/-0.05 [.043+/-0.002]	4.9
0.3-0.35mm (#22)	1.00+/-0.05 [.039+/-0.002]	6.0

WIRE SIZE	CRIMP HEIGHT mm [INCH]	CRIMP HEIGHT REFERENCE SETTING
1.25-1.37mm (#16)	1.34+/-0.05 [.053+/-0.002]	2.7
0.75-0.86mm (#18)	1.15+/-0.05 [.045+/-0.002]	4.6
0.53-0.66mm (#20)	1.10+/-0.05 [.043+/-0.002]	4.9



- 1 RECOMMENDED SPARE PARTS
- 2 REFER TO SUPPLIED INSTRUCTION SHEET FOR CLEANING, LUBRICATION & STORAGE OF APPLICATOR.
- 3 APPLY PART NUMBER 2-23419-6 LOCTITE TO THREADS OF ITEM 242.
- 4 CRIMP HEIGHT REFERENCE SETTING WAS THE SETTING USED WHEN THE APPLICATOR WAS QUALIFIED AT THE FACTORY. ADJUSTMENT MAY BE NECESSARY WHEN RUNNING APPLICATOR IN THE FIELD.
- 5. UNLESS SPECIFIED OTHERWISE TORQUE VALUES SHALL BE USED PER DOCUMENT, 101-35000.

**\*WARNING**  
ON INSTALLATION, SET WIRE DISC TO CRIMP HEIGHT REFERENCE SETTING FOR LARGEST WIRE SIZE. CRIMP HEIGHT REFERENCE SETTINGS GREATER THAN THE VALUE SHOWN MAY CAUSE DAMAGE TO THE CRIMP TOOLING. REFER TO THE INSTRUCTION SHEET FOR PROPER SETUP AND ADJUSTMENTS.

**PACIFIC VERSION**  
Shown on sheets 3 of 4 & 4 of 4  
(Atlantic version shown on sheets 1 of 4 & 2 of 4)

LOC	DIST	REVISIONS					
		P	LTN	DESCRIPTION	DATE	OWN	APVD
A	66	-	-	SEE SHEET 1	-	-	-

-	1	1	2119791-9	DEPRESSOR, WIRE	286
-	1	1	2119082-9	CAM, SNAIL, INSULATION ADJUSTMENT	244
-	1	1	2079764-1	WASHER, WAVE SPRING, CREST-TO-CREST	243
-	1	1	2119083-1	RETAINER, INSULATION DIAL	242
-	1	1	7-18023-7	SCR, SKT HD CAP M3 X 4.0	241
-	-	1	2119580-1	MECHANICAL FEED ASSEMBLY	239
-	1	-	2844940-1	AIR FEED MODULE	238
-	REF	REF	994970-2	COUNTER, MAGNETIC	164
-	1	-	2119641-2	FEED CAM, AIR FEED	151
-	1	1	2168083-8	SCR, SKT HD CAP, RoHS, M4 X 16	144
-	4	4	2168083-9	SCR, SKT HD CAP, RoHS, M4 X 20	143
-	-	1	2119653-2	FEED CAM, POST FEED	142
-	1	1	1-1803583-0	APPLICATOR BASIC ASSEMBLY, SF	141
-	1	1	1803516-1	RAM ASSEMBLY, SF PACIFIC	140
-	1	1	2844908-1	SCREW, LOCKING	99
-	1	1	2844907-1	POST, LOCKING	98
-	1	1	455888-4	SPACER, CRIMPER	82
-	1	1	1803607-3	DOCUMENTATION PACKAGE	71
-	1	1	2119943-1	WASHER, SPACER	69
-	1	1	2119740-1	TAG, IDENTIFICATION	67
-	2	2	2168078-1	SCREW, DRIVE, RH, RoHS, 2 x .188	66
-	1	1	5-18022-5	SCR, HEX HD CAP, M4 X 6.0	59
-	1	1	1338685-1	PAWL, FEED	56
-	2	2	1-2168083-0	SCR, SKT HD CAP, RoHS, M4 X 10	53
-	1	1	1803382-2	HOLD DOWN, SPRING LOADED	50
-	1	2	18023-9	SCR, SKT HD CAP M4 X 6.0	49
-	-	1	2119652-1	FEED CAM, PRE FEED	48
-	1	1	1803602-1	SCR, BHSC, RoHS (M8 X 25)	41
-	1	1	1752356-3	SUPPORT, TERMINAL	34
-	2	2	2079383-5	SCR, BHSC, RoHS (M4 X 20)	33
-	2	2	2-2844962-4	SPACER, CYLINDRICAL, STRIP GUIDE	30
-	1	1	2844992-1	ASSEMBLY, STRIP GUIDE	29
-	1	1	455888-6	SPACER, CRIMPER	28
-	1	1	1320928-2	STRIP GUIDE	24
-	1	1	2168083-2	SCR, SKT HD CAP, RoHS, M4 X 8.0	21
-	2	2	1-18028-2	WASHER, FLAT, REG M4	20
-	1	1	2119533-1	STRIPPER, SIDE FEED	19
-	1	1	2119806-1	INSERT, SHEAR	13
-	1	1	3-22280-3	SPRING, COMPRESSION	12
-	1	1	1-356885-4	STOP, SHEAR	11
-	1	1	2119805-1	SHEAR HOLDER, FRONT	10
-	1	1	1803095-3	FLOATING SHEAR, FRONT	9
-	1	1	1333203-4	ANVIL, COMBINATION	8
-	-	-	-	-	7
-	-	-	-	-	6
-	1	1	1-2119757-2	DEPRESSOR, SHEAR	5
-	1	1	2-238011-5	BLOCK, CRIMPER SPACER	4
-	1	1	1-1803260-3	CRIMPER, INSULATION F PREMIUM	3
-	1	1	455888-5	SPACER, CRIMPER	2
-	1	1	2-456404-5	CRIMPER, WIRE PREMIUM	1

DIMENSIONS:		TOLERANCES UNLESS OTHERWISE SPECIFIED:		MATERIAL:		FINISH:		WEIGHT:		SCALE:	
mm	0 PLC ±	1 PLC ±	2 PLC ±	3 PLC ±	4 PLC ±	ANGLES	FINISH				

LOC	DIST	REVISIONS					
A	66	P	LTM	DESCRIPTION	DATE	DWN	APVD
		-		SEE SHEET 1			

# FEED TYPE MECHANICAL

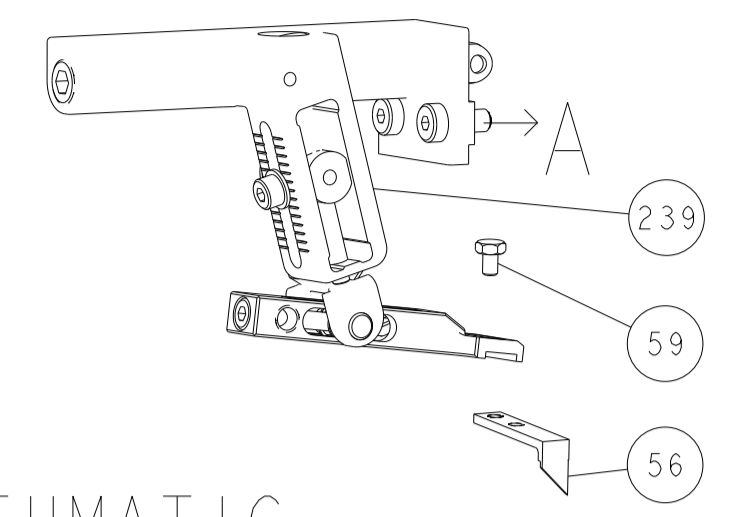

## PNEUMATIC

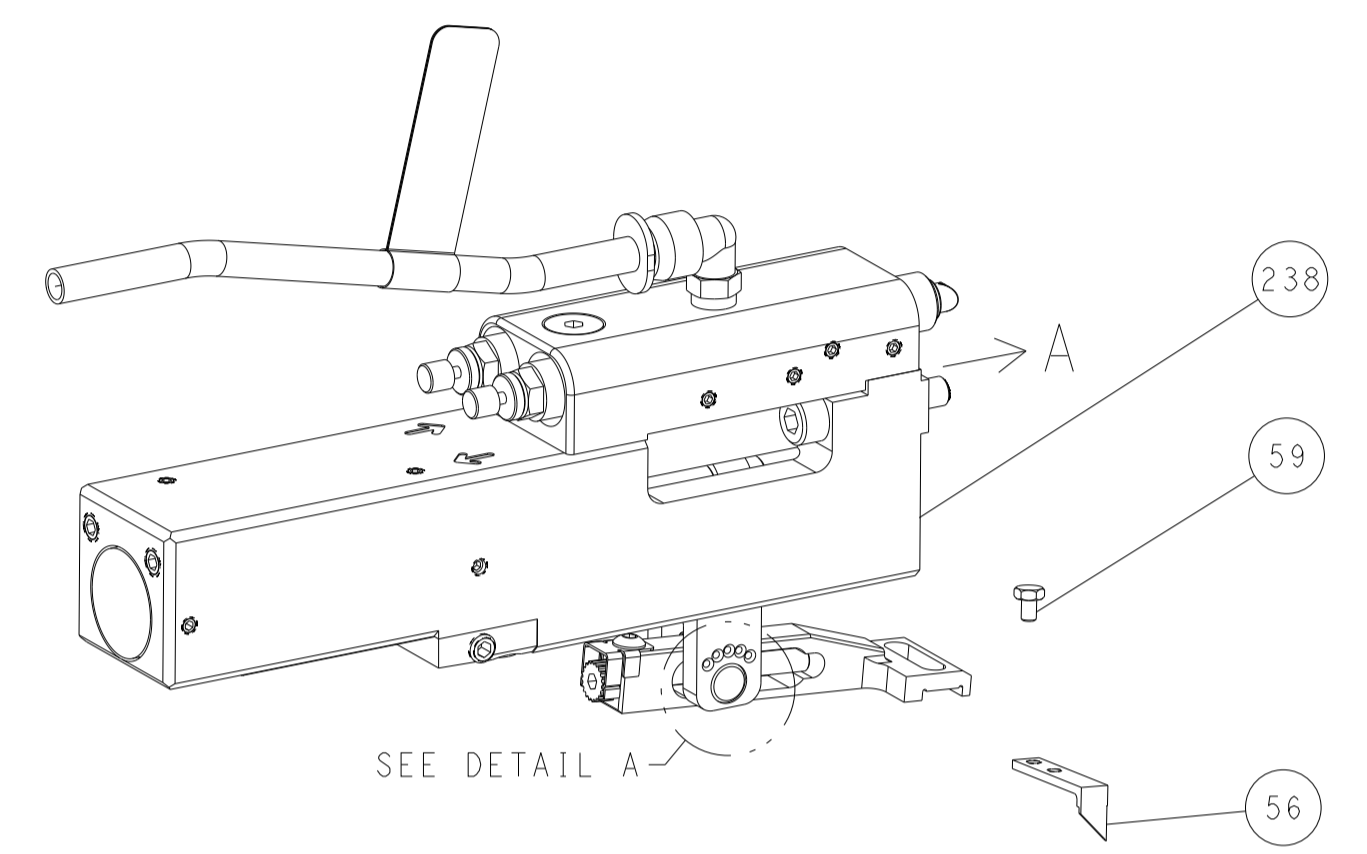

## FEED SPRING SETTING POSITION (SHOWN FROM REAR SIDE)

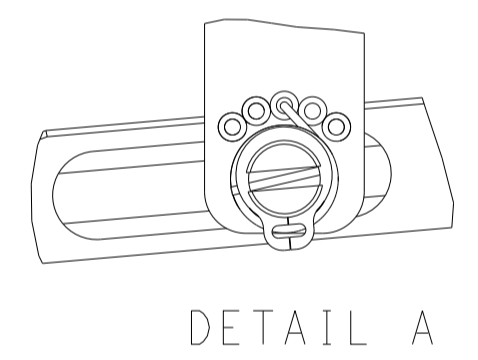

# CAM POSITIONS

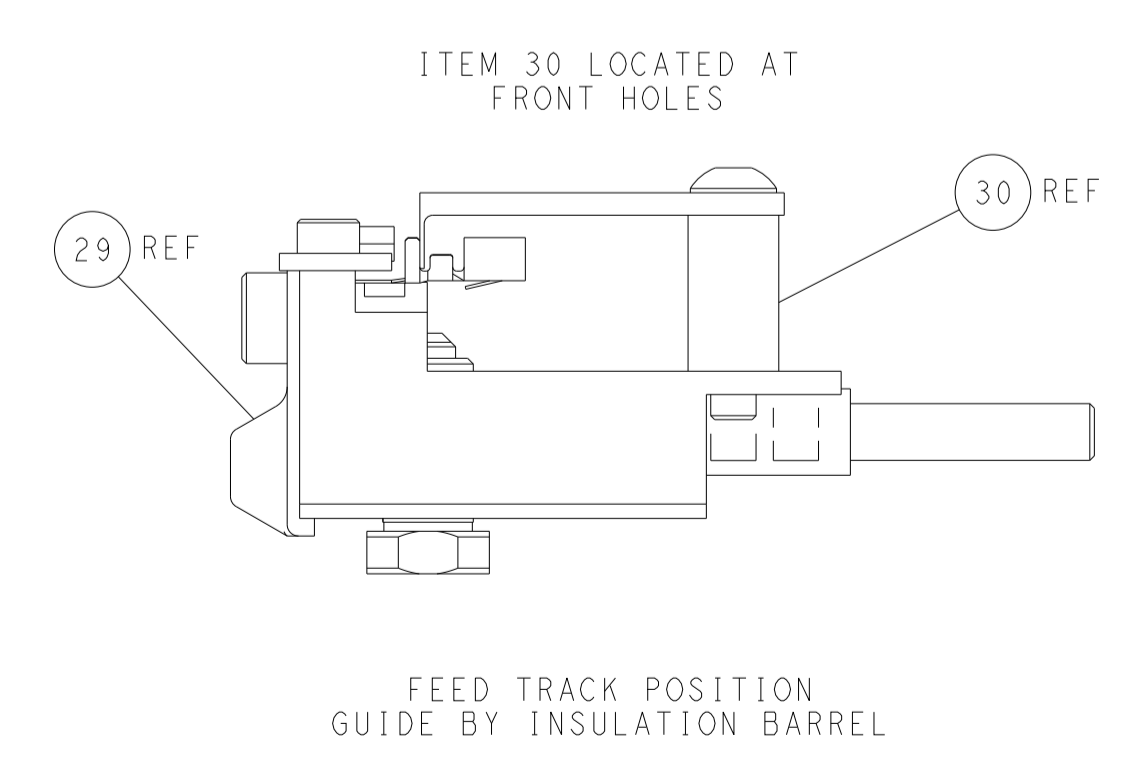
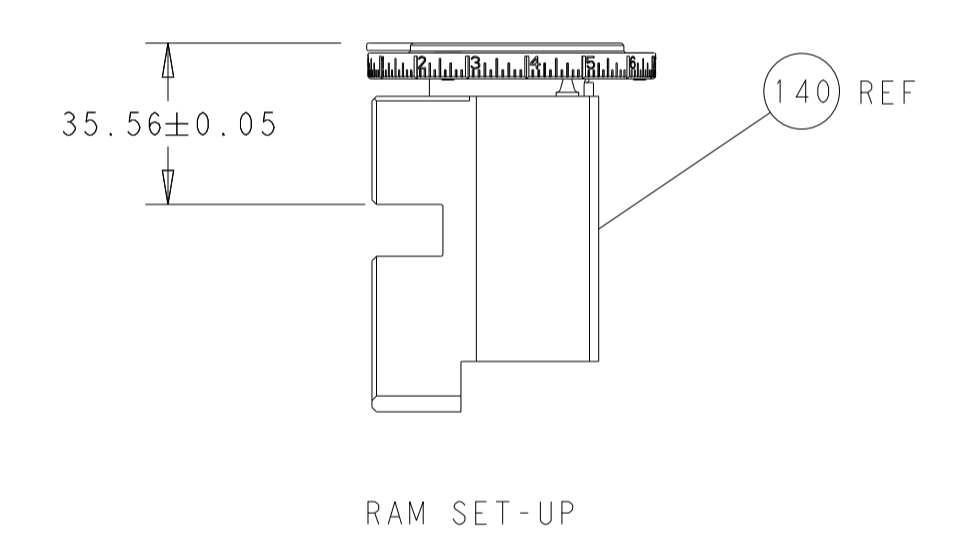
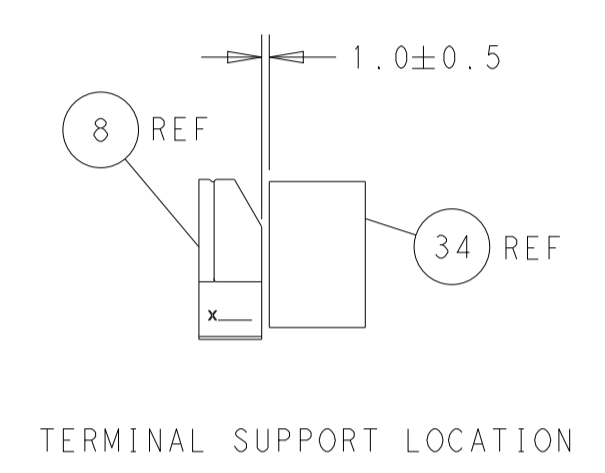
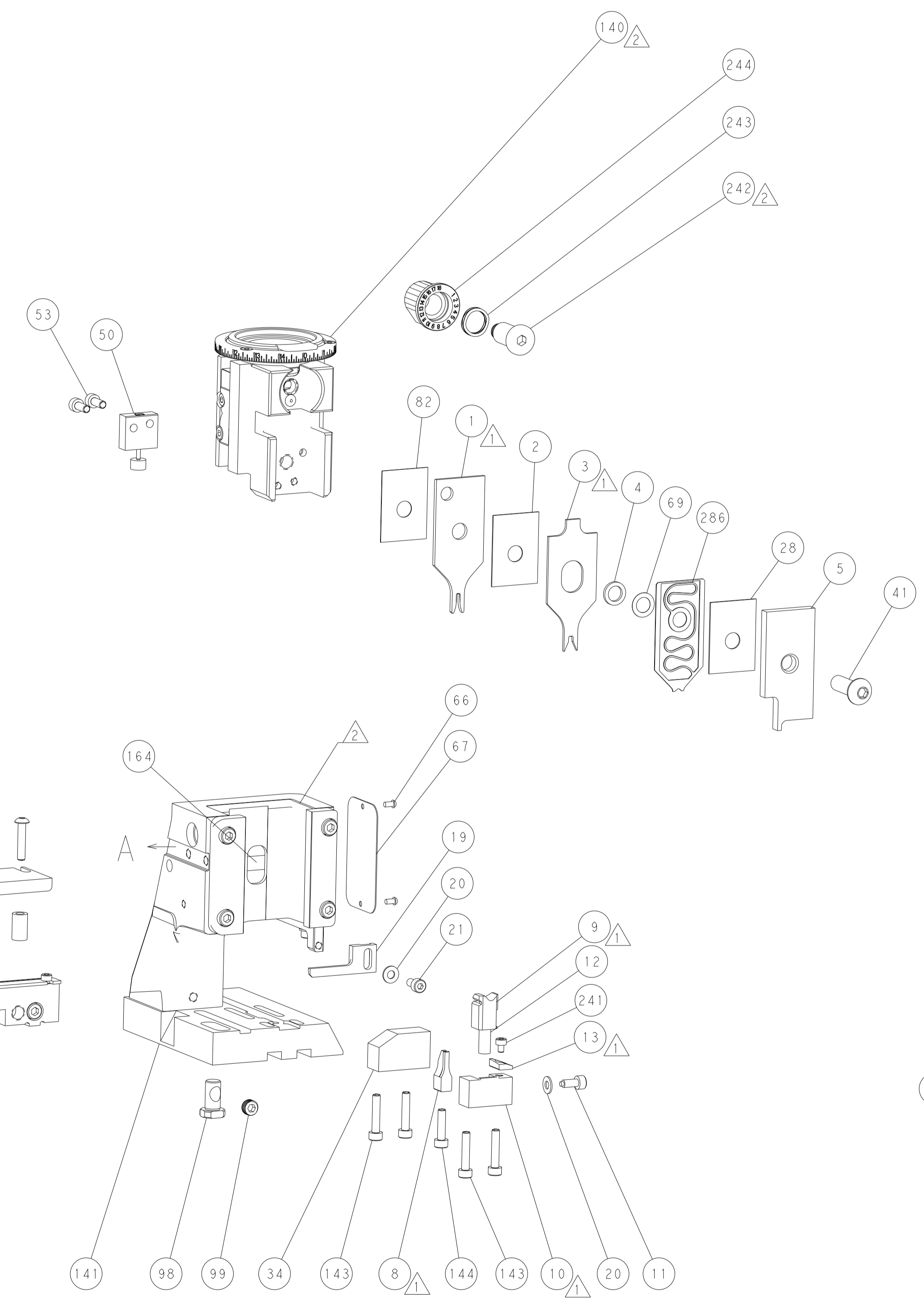
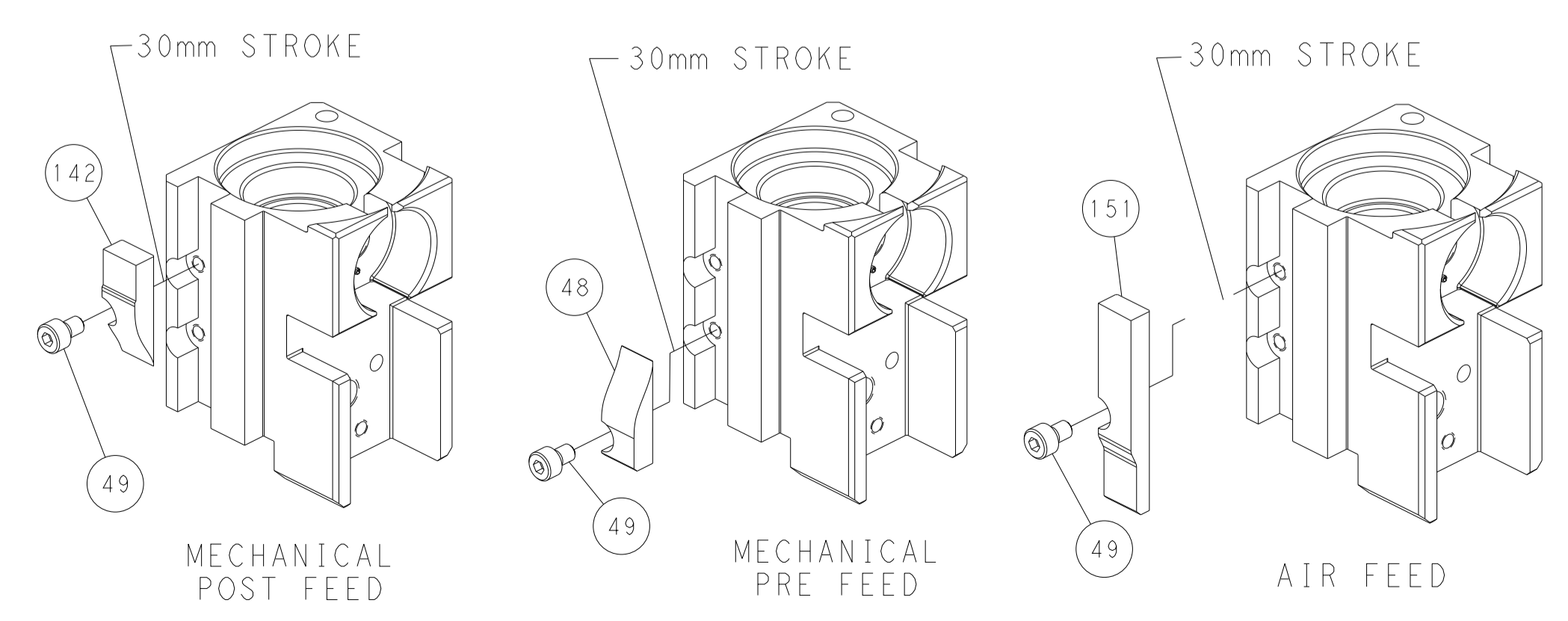

**PACIFIC VERSION**  
 Shown on sheets 3 of 4 & 4 of 4  
 (Atlantic version shown on sheets 1 of 4 & 2 of 4)

<small>THIS DRAWING IS UNPUBLISHED. RELEASED FOR PUBLICATION. ALL RIGHTS RESERVED. © 2011 BY TYCO ELECTRONICS CORPORATION. THIS DRAWING IS THE PROPERTY OF TYCO ELECTRONICS CORPORATION AND IS NOT TO BE REPRODUCED OR TRANSMITTED IN ANY FORM OR BY ANY MEANS, ELECTRONIC OR MECHANICAL, INCLUDING PHOTOCOPYING, RECORDING, OR BY ANY INFORMATION STORAGE AND RETRIEVAL SYSTEM, WITHOUT THE WRITTEN PERMISSION OF TYCO ELECTRONICS CORPORATION.</small>		DWN: H. HUANG 28SEP2011 CHK: S. XI 28SEP2011 APVD: J. CRUZ 28SEP2011	NAME: TE Connectivity Harrisburg, PA 17105-3608
DIMENSIONS: mm TOLERANCES UNLESS OTHERWISE SPECIFIED: 0 PLC ± 1 PLC ± 2 PLC ± 3 PLC ± 4 PLC ± ANGLES FINISH ±	APPLICATION SPEC: - PRODUCT SPEC: - MATERIAL: -	NAME: Ocean Side Feed Applicator SIZE: A1 CAGE CODE: 00779 DRAWING NO: 2151113 SCALE: 1:2	RESTRICTED TO: - SHEET: 4 OF 4 REV: M