

REVISIONS					
REV	ECO	DESCRIPTION	DATE	BY	APPR
B1	-	RELEASE NEW DWG FORMAT	05/10/14	DRACK	

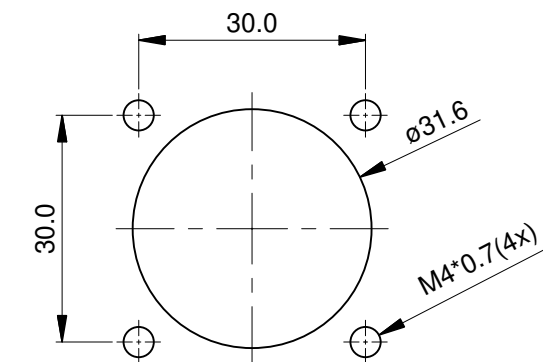

MOUNTING HOLE

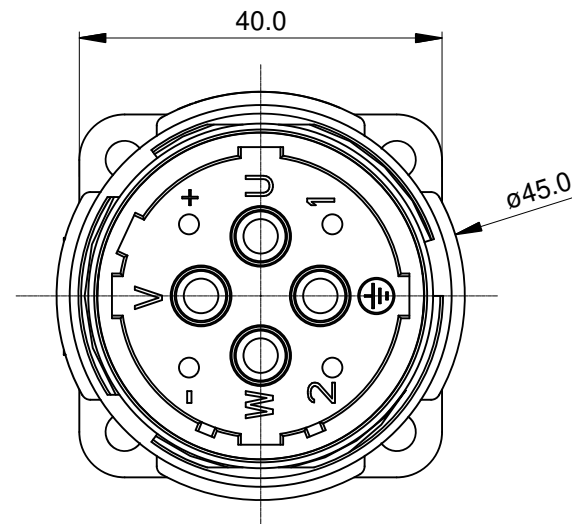
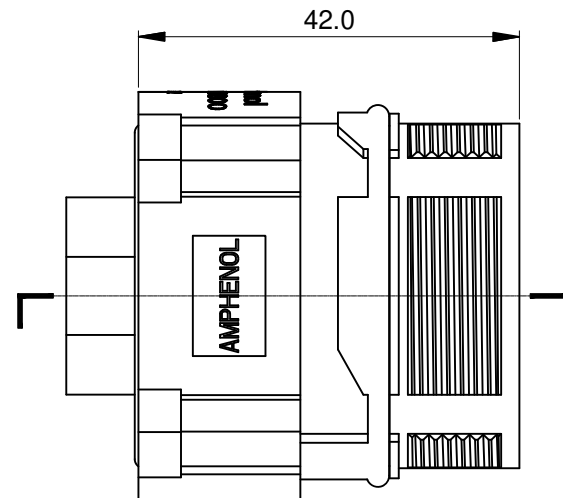
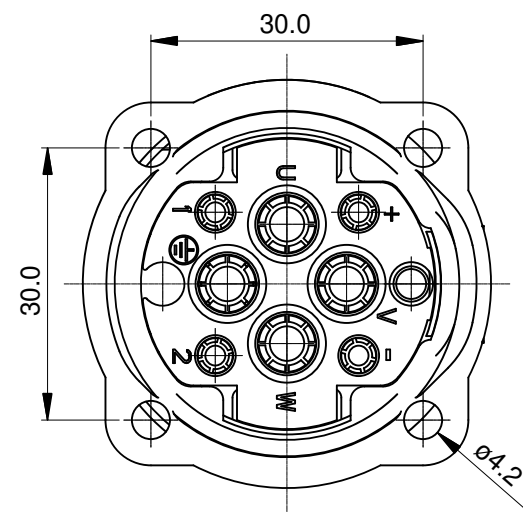
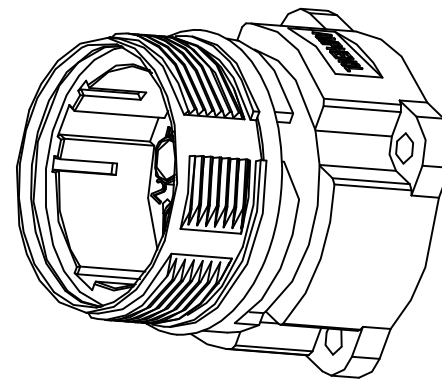
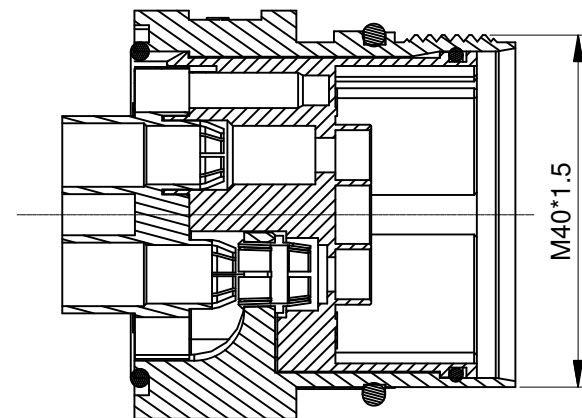

NOTES: UNLESS OTHERWISE SPECIFIED

- MATERIAL:
 - INSULATION INSERT: PA66, UL94 V0
 - SEAL: VITON
 - HOUSING BODY: ZINC DIE CAST, NICKEL PLATED
 - COUPLING NUT: COPPER ALLOY, NICKEL PLATED
- SPECIFICATIONS:
 - 2.1 CURRENT RATING: SIGNAL: 30 AMPS
POWER: 75AMPS
 - 2.2 VOLTAGE RATING: SIGNAL: 250V AC/DC
POWER: 630V AC/DC
 - 2.3 OPERATING TEMPERATURE: -20°C TO +130°C
 - 2.4 DIELECTRIC WITHSTANDING VOLTAGE: LESS THAN 2 MILLIAMPS CURRENT LEAKAGE @ SIGNAL: 4000VOLTS AC.
POWER: 6000 VOLTS AC.
 - 2.5 DEGREE OF PROTECTION: IP67 (MATED CONDITION)
 - 2.6 DEGREE OF POLLUTION: 3 PER UL840
 - 2.7 OVERVOLTAGE CATEGORY: III PER UL840
 - 2.8 MATING CYCLE DURABILITY: >50 CYCLES
 - 2.9 RoHS COMPLIANT
- ALL DIMENSIONS ARE FOR REFERENCE USE ONLY.

QUANTITY	SEE PART NUMBER CHART PART NUMBER	DESCRIPTION	ITEM
MATERIALS LIST			
UNLESS OTHERWISE SPECIFIED 1) All dimensions are in metric(mm). 2) Tolerances are as follows: 1 PL DEC ±0.30 2 PL DEC ±0.15 3 PL DEC ±0.08 3) Note reference =		SIGNATURES DRAWN: Drack CHECKED: ENGINEER: APPROVAL:	DATE 05/10/14
MATERIAL SPECIFICATIONS:		<div style="text-align: center;"> <h1>Amphenol</h1> <p>Sine Systems - www.amphenol-sine.com 44724 Morley Drive Clinton Township, MI 48036</p> </div>	
PROCESS SPECIFICATIONS:			
NEXT ASSY:		CUSTOMER: THIS DRAWING IS SUPPLIED FOR INFORMATION ONLY. DESIGN FEATURES, SPECIFICATIONS AND PERFORMANCE DATA SHOWN HEREON ARE THE PROPERTY OF THE AMPHENOL CORPORATION. NO RIGHTS OF REPRODUCTION ARE IMPLIED. ALL DIMENSIONS ARE SUBJECT TO NORMAL MANUFACTURING VARIATIONS.	SIZE: B TYPE: C- DWG NO.: MC1NJN0800 REVISION: B1 SCALE: NONE SHEET 1 OF 1

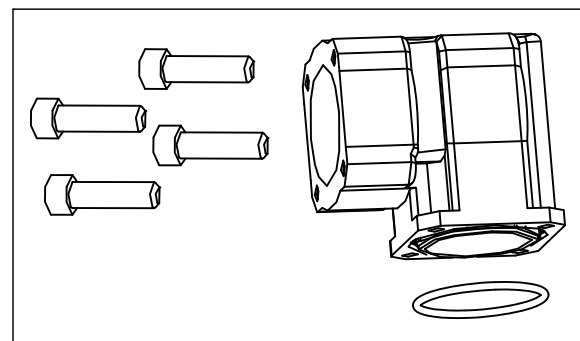

TITLE: M40C REC., RA, 8POS(4+4), FLANGE MOUNT
DWG NO.: MC1NJN0800
REV: B1
SH: 1
OF: 1