

SINGLE IDC CONTACT 12-18 AWG: 9177-500

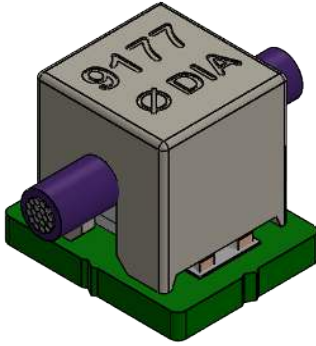

General Information

GENERAL DESCRIPTION



The 917X series of surface mount Insulation Displacement Connectors (IDC) were developed to meet the harsh requirements of automotive and industrial applications. This industry proven series of connectors provides a robust, reliable, and efficient method to connect individual wires ranging from 12 AWG to 30 AWG directly to a PCB. The single contact design can function as a standalone component. It provides our designers access to IDC technology in an easy-to-use form factor allowing them to bring power and signal to a PCB in a wide range of applications.

These connectors have been tested to various levels of shock, vibration, and temperature cycling to prove their reliability and robustness. The simplicity of inserting a wire into an SMT contact with a small tool or optional retention / termination cap allows a wide range of devices to be connected to the PCB without soldering. The IDC contact provides a gas-tight connection to the wire and the optional cap provides a positive strain relief even in the harshest conditions. In case of repair, the wires can be removed and replaced up to three times.

APPLICATIONS

- Industrial motor controls, drives & pumps
- Commercial building wiring and electrical systems
- Outdoor/Transportation lighting
- Solar and alternative energy

FEATURES AND BENEFITS

- Proven “gas tight” cold welded wire termination
- Redundant contact systems provides enhanced wire retention and high current carrying capabilities
- Cost effective insulator-less contact system
- Optional termination cap provides additional strain relief for severe environments

ELECTRICAL

- Current Rating: 15 Amps/Contact
- Voltage Rating: 600 VAC (RMS) or DC Equivalent

ENVIRONMENTAL

- Operating Temperature: -40°C to +125°C
- Storage Temperature: -40°C to +70°C

MECHANICAL

- Cap Insulator Material: High Temperature Nylon: UL94V-0
- Contact Material: Phosphor Bronze
- Contact Plating: Pure tin over nickel
- Durability: 3 termination cycles

HOW TO ORDER – CONTACT OPTIONS

70 Prefix	9177 Series	001 No. of Ways 001 = 1	5XX Description 591 = 12AWG Stranded and Solid 501 = 14AWG Stranded and Solid 512 = 16AWG Stranded and Solid 522 = 18AWG Stranded and Solid	006 Plating 006 = Pure Tin all over
---------------------	-----------------------	--------------------------------------	---	--



Safety Standards: UL 1977-File #E90723, CSA C22.2 NO. 182.3

HOW TO ORDER – CAP OPTIONS - SEE PAGE 45

60 Prefix	9177 Series	001 No. of Ways 001 = 1
---------------------	-----------------------	--------------------------------------

5XX Description

100 Color 100 = White (Standard) 000 = Black (Special)
--

PART NUMBER	DIM. A	TEXT	WIRE	COLOR
60-9177-001-542-100	3.90	ø 4.2	12 AWG	WHITE (STANDARD)
60-9177-001-542-000				BLACK (SPECIAL ORDER)
60-9177-001-531-100	2.75	ø 3.1	12 AWG	WHITE (STANDARD)
60-9177-001-531-000				BLACK (SPECIAL ORDER)
60-9177-001-526-100	2.25	ø 2.6	14 AWG	WHITE (STANDARD)
60-9177-001-526-000				BLACK (SPECIAL ORDER)
60-9177-001-522-100	1.90	ø 2.2	16 AWG	WHITE (STANDARD)
60-9177-001-522-000				BLACK (SPECIAL ORDER)
60-9177-001-519-100	1.65	ø 1.9	18 AWG	WHITE (STANDARD)
60-9177-001-519-000				BLACK (SPECIAL ORDER)



The Important Information/Disclaimer is incorporated in the catalog where these specifications came from or available online at www.kyocera-avx.com/disclaimer/ by reference and should be reviewed in full before placing any order.

TDS-WTB-0004 | Rev 1

SINGLE IDC CONTACT 12-18 AWG: 9177-500

Contact Detail

CONTACT DETAILS

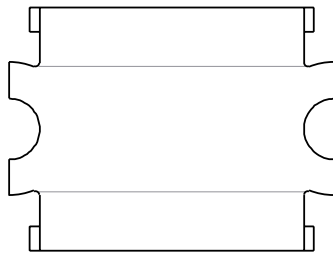
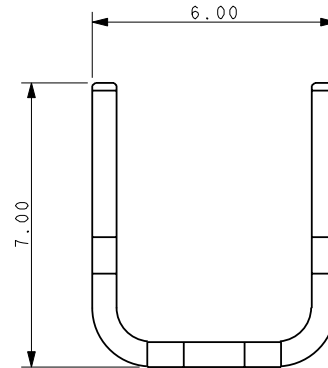
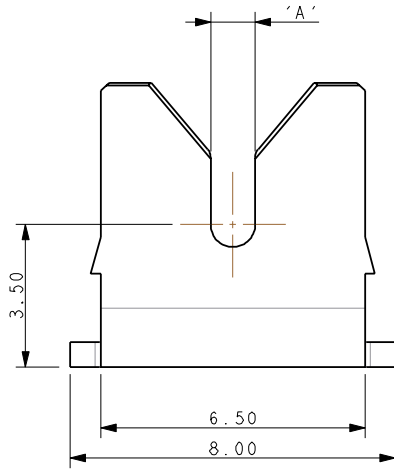

CODE SHEET	ACCEPTED WIRE GAUGE	'A'
591	12AWG STRANDED AND SOLID	1.50
501	14AWG STRANDED AND SOLID	1.10
512	16AWG STRANDED AND SOLID	0.82
522	18 AWG STRANDED AND SOLID	0.72

NOTES:

- CONNECTOR FOR IDC WIRE TO BOARD CONNECTION.
- CONTACT MATERIAL: PHOSPHORE BRONZE.
- CONTACT PLATING: PURE TIN.
- CONTACTS DESIGNED TO ACCEPT BETWEEN 12 AND 18 GAUGE STRANDED WIRE, SEE TABLE.
- ALL DIMENSIONS FOR REFERENCE UNLESS OTHERWISE STATED.
- FOR FULL PRODUCT SPECIFICATIONS REFER TO AVX SPECIFICATION 201-01-208 AND APPLICATION NOTES 201-01-209.
- SMT PCB LAYOUT, REFER TO PAGE 43.
- PACKING IN TAPE AND REEL, QUANTITY PER REEL 700.
- ASSEMBLY TOOLING ON PAGE 44.
- UL REFERENCE E90723 (US AND CANADA).

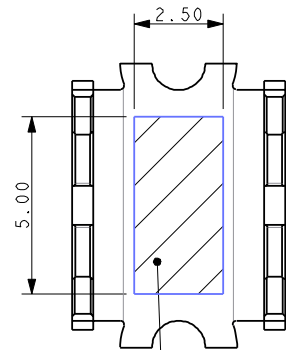

PICK AND PLACE AREA

PACKING DETAILS

REEL QTY	700
LEADER	480mm
TRAILER	120mm

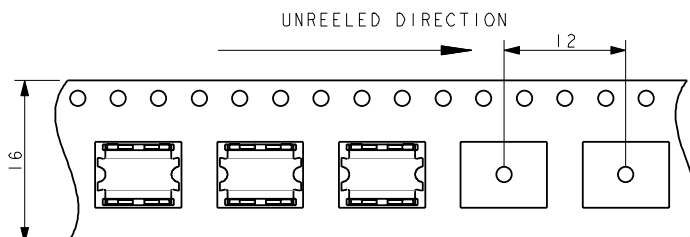
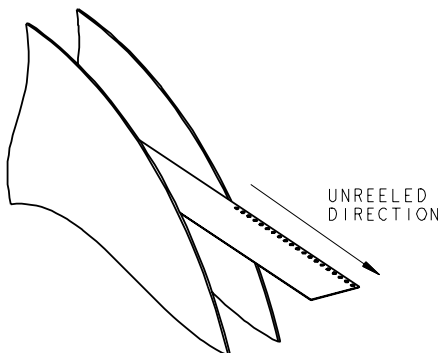

SINGLE IDC CONTACT 12-18 AWG: 9177-500

IDC Wire to Board Connector Single Contact

12-18 AWG IDC WIRE TO BOARD CONNECTOR SINGLE CONTACT

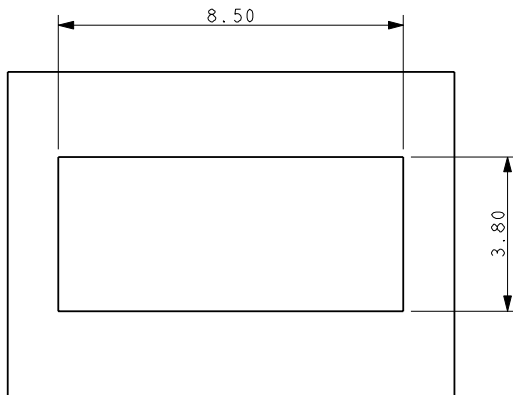

SUGGESTED PCB LAYOUT

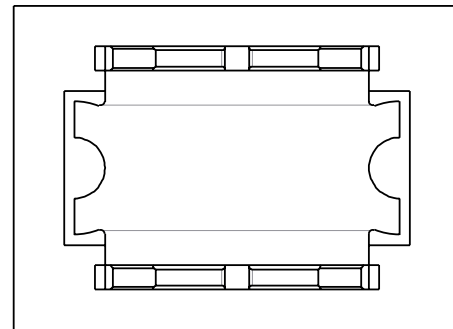

ORIENTATION OF CONTENT ON PAD

NOTES:

1. FOR FULL PRODUCT SPECIFICATION REFER TO AVX SPEC 201-01-208 AND Application Notes 201-01-209
2. DIMENSIONS SHOWN ARE REFERENCE DIMENSIONS.
3. ASSEMBLY TOOLING ON PAGE 44.

SINGLE IDC CONTACT 12-18 AWG: 9177-500

Assembly Tooling

ASSEMBLY TOOLING

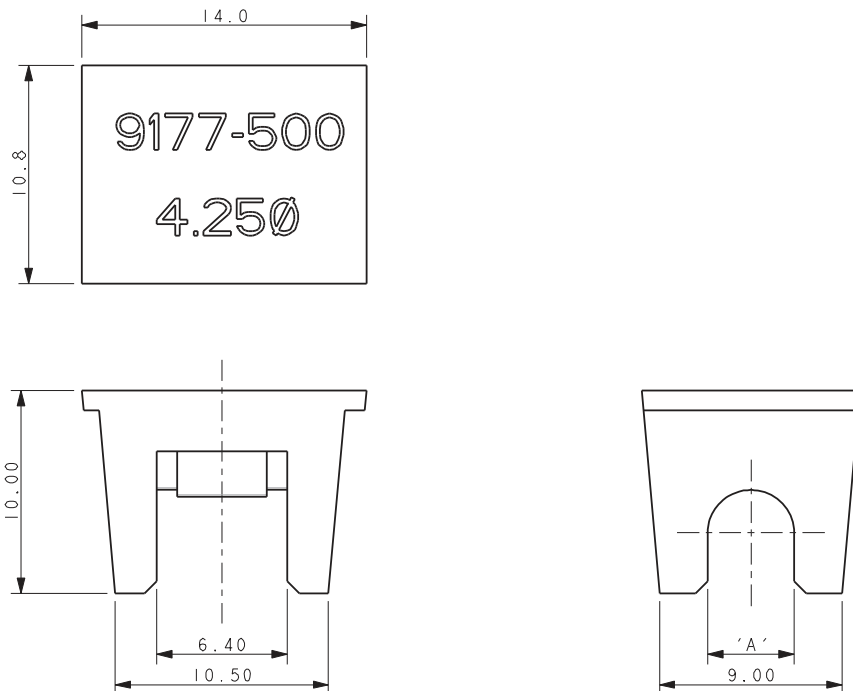

Wire Gauge	Max Insulation (Dimensions 'A')	Tool Number Metal Tool for High Volume	Tool Number Plastic Tool for Small to Medium Volume
12-18 AWG	Ø 4.25	06-9177-7020-01-001	06-9177-7022-01-001
12-18 AWG	Ø 3.50	06-9177-7020-02-001	06-9177-7022-02-001
12-18 AWG	Ø 2.75	06-9177-7020-03-001	06-9177-7022-03-001

NOTES:

1. ASSEMBLY TOOLING FOR CONTACTS 70-9177-001-5XX-006 ONLY.
2. MINIMUM AREA OF PCB TO BE KEPT CLEAR OF COMPONENTS. TRACKS PERMISSIBLE.
3. MAXIMUM COMPONENT HEIGHT 9.0MM IN THIS AREA.
4. REFER TO TABLE FOR CORRECT TOOL/WIRE COMBINATION.
5. REFER TO APPLICATION NOTE 201-01-209 FOR FURTHER INFORMATION.
6. DIMENSIONS FOR TOOL ARE REFERENCE DIMENSIONS.

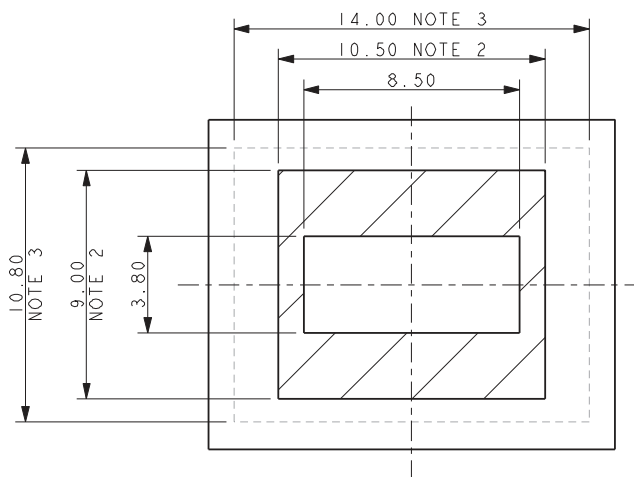

SINGLE IDC CONTACT 12-18 AWG: 9177-500

Cap Details

CAP DETAILS

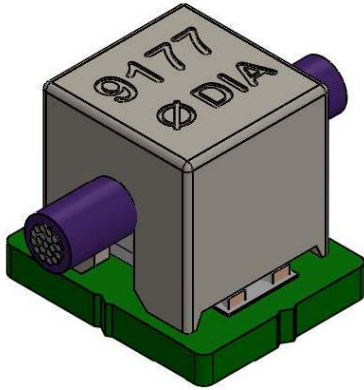

PART NUMBER	DIM. A	TEXT	WIRE	COLOR
60-9177-001-542-100	3.90	ø 4.2	12 AWG	WHITE (STANDARD)
60-9177-001-542-100				BLACK (SPECIAL ORDER)
60-9177-001-531-100	2.75	ø 3.1	12 AWG	WHITE (STANDARD)
60-9177-001-531-000				BLACK (SPECIAL ORDER)
60-9177-001-526-100	2.25	ø 2.6	14 AWG	WHITE (STANDARD)
60-9177-001-526-000				BLACK (SPECIAL ORDER)
60-9177-001-522-100	1.90	ø 2.2	16 AWG	WHITE (STANDARD)
60-9177-001-522-000				BLACK (SPECIAL ORDER)
60-9177-001-519-100	1.65	ø 1.9	18 AWG	WHITE (STANDARD)
60-9177-001-519-000				BLACK (SPECIAL ORDER)

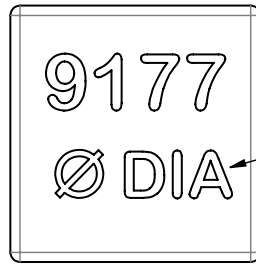

TEXT. SEE P.N. TABLE

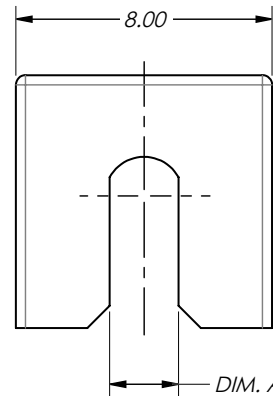
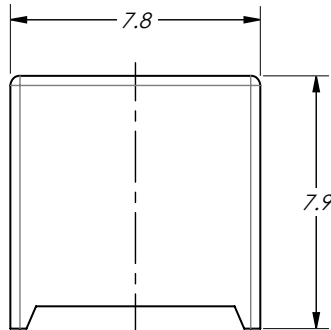
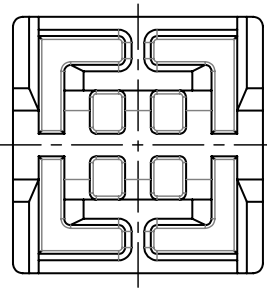

NOTES:

1. CAP FOR TERMINATING WIRES TO 9177-500 SERIES CONTACTS.
2. MATERIAL: HIGH TEMPERATURE NYLON; UL94V-0.
3. FOR FULL PRODUCT SPECIFICATION, REFER TO PRODUCT SPEC 201-01-208 AND APPLICATION NOTES 201-01-209.
4. PACKAGING TO BE BULK WITH 700 PARTS PER BAG.
5. FOR INSTALLATION DETAILS, SEE DRAWING 70-9177-001-5XX-006S.
6. PCB MUST BE CLEAR OF COMPONENTS ALLOWING CAP TO SEAT.