

CY74FCT2541T

8-BIT BUFFER/LINE DRIVER WITH 3-STATE OUTPUTS

SCCS041B – SEPTEMBER 1994 – REVISED SEPTEMBER 2001

- Function and Pinout Compatible With FCT and F Logic
- 25-Ω Output Series Resistors to Reduce Transmission-Line Reflection Noise
- Reduced V_{OH} (Typically = 3.3 V) Versions of Equivalent FCT Functions
- Edge-Rate Control Circuitry for Significantly Improved Noise Characteristics
- I_{off} Supports Partial-Power-Down Mode Operation
- ESD Protection Exceeds JESD 22
 - 2000-V Human-Body Model (A114-A)
 - 200-V Machine Model (A115-A)
 - 1000-V Charged-Device Model (C101)
- Matched Rise and Fall Times
- Fully Compatible With TTL Input and Output Logic Levels
- 12-mA Output Sink Current
15-mA Output Source Current
- 3-State Outputs

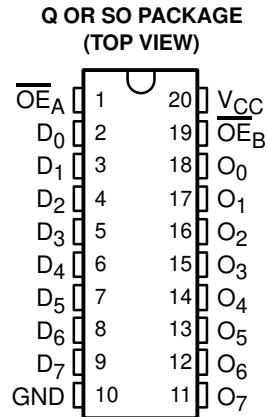

description

The CY74FCT2541T is an octal buffer and line driver designed to be employed as a memory-address driver, clock driver, and bus-oriented transmitter/receiver. On-chip termination resistors at the outputs reduce system noise caused by reflections. The CY74FCT2541T can replace the CY74FCT541T to reduce noise in an existing design. The speed of the CY74FCT2541T is comparable to bipolar logic counterparts, while reducing power dissipation. Input and output voltage levels allow direct interface with TTL and CMOS devices without external components.

This device is fully specified for partial-power-down applications using I_{off} . The I_{off} circuitry disables the outputs, preventing damaging current backflow through the device when it is powered down.

ORDERING INFORMATION

TA	PACKAGE†		SPEED (ns)	ORDERABLE PART NUMBER	TOP-SIDE MARKING
–40°C to 85°C	QSOP – Q	Tape and reel	4.1	CY74FCT2541CTQCT	FCT2541C
		Tube	4.1	CY74FCT2541CTSOC	FCT2541C
	SOIC – SO	Tape and reel	4.1	CY74FCT2541CTSOCT	FCT2541C
		Tube	4.8	CY74FCT2541ATQCT	FCT2541A
	SOIC – SO	Tape and reel	4.8	CY74FCT2541ATSOCT	FCT2541A
		Tube	8	CY74FCT2541TQCT	FCT2541
	SOIC – SO	Tape and reel	8	CY74FCT2541TSOCT	FCT2541
		Tube	8	CY74FCT2541TSOC	FCT2541

† Package drawings, standard packing quantities, thermal data, symbolization, and PCB design guidelines are available at www.ti.com/sc/package.



Please be aware that an important notice concerning availability, standard warranty, and use in critical applications of Texas Instruments semiconductor products and disclaimers thereto appears at the end of this data sheet.

PRODUCTION DATA information is current as of publication date. Products conform to specifications per the terms of Texas Instruments standard warranty. Production processing does not necessarily include testing of all parameters.

 **TEXAS
INSTRUMENTS**

POST OFFICE BOX 655303 • DALLAS, TEXAS 75265

Copyright © 2001, Texas Instruments Incorporated

CY74FCT2541T

8-BIT BUFFER/LINE DRIVER

WITH 3-STATE OUTPUTS

SCCS041B – SEPTEMBER 1994 – REVISED SEPTEMBER 2001

FUNCTION TABLE

INPUTS			OUTPUT
\overline{OE}_A	\overline{OE}_B	D	
L	L	L	L
L	L	H	H
H	H	X	Z

H = High logic level, L = Low logic level,
X = Don't care, Z = High-impedance state

logic diagram (positive logic)

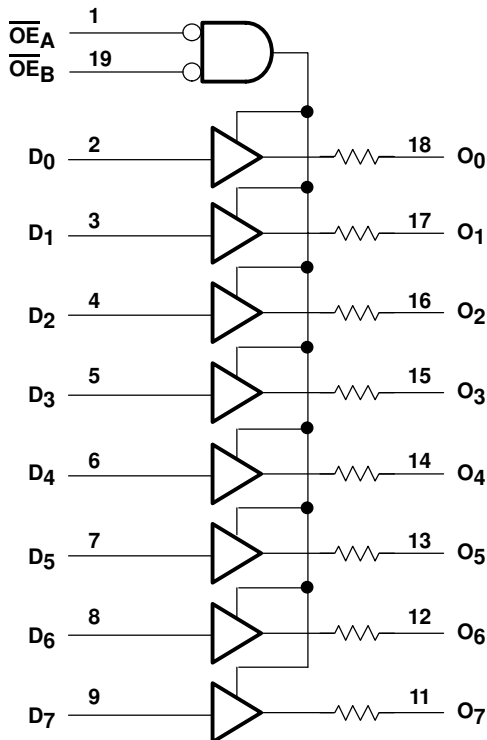

absolute maximum rating over operating free-air temperature range (unless otherwise noted)†

Supply voltage range to ground potential	-0.5 V to 7 V
DC input voltage range	-0.5 V to 7 V
DC output voltage range	-0.5 V to 7 V
DC output current (maximum sink current/pin)	120 mA
Package thermal impedance, θ_{JA} (see Note 1): Q package	68°C/W
SO package	58°C/W
Ambient temperature range with power applied, T_A	-65°C to 135°C
Storage temperature range, T_{stg}	-65°C to 150°C

† Stresses beyond those listed under “absolute maximum ratings” may cause permanent damage to the device. These are stress ratings only, and functional operation of the device at these or any other conditions beyond those indicated under “recommended operating conditions” is not implied. Exposure to absolute-maximum-rated conditions for extended periods may affect device reliability.

NOTE 1: The package thermal impedance is calculated in accordance with JESD 51-7.



CY74FCT2541T
8-BIT BUFFER/LINE DRIVER
WITH 3-STATE OUTPUTS

SCCS041B – SEPTEMBER 1994 – REVISED SEPTEMBER 2001

recommended operating conditions (see Note 2)

		MIN	NOM	MAX	UNIT
V_{CC}	Supply voltage	4.75	5	5.25	V
V_{IH}	High-level input voltage	2			V
V_{IL}	Low-level input voltage			0.8	V
I_{OH}	High-level output current			-15	mA
I_{OL}	Low-level output current			12	mA
T_A	Operating free-air temperature	-40		85	°C

NOTE 2: All unused inputs of the device must be held at V_{CC} or GND to ensure proper device operation.

CY74FCT2541T

8-BIT BUFFER/LINE DRIVER

WITH 3-STATE OUTPUTS

SCCS041B – SEPTEMBER 1994 – REVISED SEPTEMBER 2001

electrical characteristics over recommended operating free-air temperature range (unless otherwise noted)

PARAMETER	TEST CONDITIONS		MIN	TYP†	MAX	UNIT	
V _{IK}	V _{CC} = 4.75 V,	I _{IN} = -18 mA	-0.7	-1.2		V	
V _{OH}	V _{CC} = 4.75 V,	I _{OH} = -15 mA	2.4	3.3		V	
V _{OL}	V _{CC} = 4.75 V,	I _{OL} = 12 mA		0.3	0.55	V	
R _{out}	V _{CC} = 4.75 V,	I _{OL} = 12 mA	20	25	40	Ω	
V _{hys}	All inputs			0.2		V	
I _I	V _{CC} = 5.25 V,	V _{IN} = V _{CC}			5	μA	
I _{IH}	V _{CC} = 5.25 V,	V _{IN} = 2.7 V			±1	μA	
I _{IL}	V _{CC} = 5.25 V,	V _{IN} = 0.5 V			±1	μA	
I _{OZH}	V _{CC} = 5.25 V,	V _{OUT} = 2.7 V			15	μA	
I _{OZL}	V _{CC} = 5.25 V,	V _{OUT} = 0.5 V			-15	μA	
I _{OS‡}	V _{CC} = 5.25 V,	V _{OUT} = 0 V	-60	-120	-225	mA	
I _{off}	V _{CC} = 0 V,	V _{OUT} = 4.5 V			±1	μA	
I _{CC}	V _{CC} = 5.25 V,	V _{IN} ≤ 0.2 V, V _{IN} ≥ V _{CC} - 0.2 V		0.1	0.2	mA	
ΔI _{CC}	V _{CC} = 5.25 V, V _{IN} = 3.4 V§, f ₁ = 0, Outputs open			0.5	2	mA	
I _{CCD¶}	V _{CC} = 5.25 V at 50% duty cycle, Outputs open, One bit switching, OE _A = OE _B = GND, V _{IN} ≤ 0.2 V or V _{IN} ≥ V _{CC} - 0.2 V			0.06	0.12	mA/MHz	
I _{C#}	V _{CC} = 5.25 V, Outputs open, OE _A = OE _B = GND	One bit switching at f ₁ = 10 MHz, at 50% duty cycle	V _{IN} ≤ 0.2 V or V _{IN} ≥ V _{CC} - 0.2 V		0.7	1.4	mA
			V _{IN} = 3.4 V or GND		1	2.4	
		Eight bits switching at f ₁ = 2.5 MHz, at 50% duty cycle	V _{IN} ≤ 0.2 V or V _{IN} ≥ V _{CC} - 0.2 V		1.3	2.6	
			V _{IN} = 3.4 V or GND		3.3	10.6	
C _i				5	10	pF	
C _o				9	12	pF	

† Typical values are at V_{CC} = 5 V, T_A = 25°C.

‡ Not more than one output should be shorted at a time. Duration of short should not exceed one second. The use of high-speed test apparatus and/or sample-and-hold techniques are preferable to minimize internal chip heating and more accurately reflect operational values. Otherwise, prolonged shorting of a high output can raise the chip temperature well above normal and cause invalid readings in other parametric tests. In any sequence of parameter tests, I_{OS} tests should be performed last.

§ Per TTL-driven input (V_{IN} = 3.4 V); all other inputs at V_{CC} or GND

¶ This parameter is derived for use in total power-supply calculations.

I_C = I_{CC} + ΔI_{CC} × D_H × N_T + I_{CCD} (f₀/2 + f₁ × N₁)

Where:

I_C = Total supply current

I_{CC} = Power-supply current with CMOS input levels

ΔI_{CC} = Power-supply current for a TTL high input (V_{IN} = 3.4 V)

D_H = Duty cycle for TTL inputs high

N_T = Number of TTL inputs at D_H

I_{CCD} = Dynamic current caused by an input transition pair (HLH or LHL)

f₀ = Clock frequency for registered devices, otherwise zero

f₁ = Input signal frequency

N₁ = Number of inputs changing at f₁

All currents are in milliamperes and all frequencies are in megahertz.

|| Values for these conditions are examples of the I_C formula.



CY74FCT2541T
8-BIT BUFFER/LINE DRIVER
WITH 3-STATE OUTPUTS

SCCS041B – SEPTEMBER 1994 – REVISED SEPTEMBER 2001

switching characteristics over operating free-air temperature range (see Figure 1)

PARAMETER	FROM (INPUT)	TO (OUTPUT)	CY74FCT2541T		CY74FCT2541AT		CY74FCT2541CT		UNIT
			MIN	MAX	MIN	MAX	MIN	MAX	
t _{PLH}	D	O	1.5	8	1.5	4.8	1.5	4.1	ns
t _{PHL}			1.5	8	1.5	4.8	1.5	4.1	
t _{PZH}	\overline{OE}	O	1.5	10	1.5	6.2	1.5	5.8	ns
t _{PZL}			1.5	10	1.5	6.2	1.5	5.8	
t _{PHZ}	\overline{OE}	O	1.5	9.5	1.5	5.6	1.5	5.2	ns
t _{PLZ}			1.5	9.5	1.5	5.6	1.5	5.2	



CY74FCT2541T

8-BIT BUFFER/LINE DRIVER

WITH 3-STATE OUTPUTS

SCCS041B – SEPTEMBER 1994 – REVISED SEPTEMBER 2001

PARAMETER MEASUREMENT INFORMATION

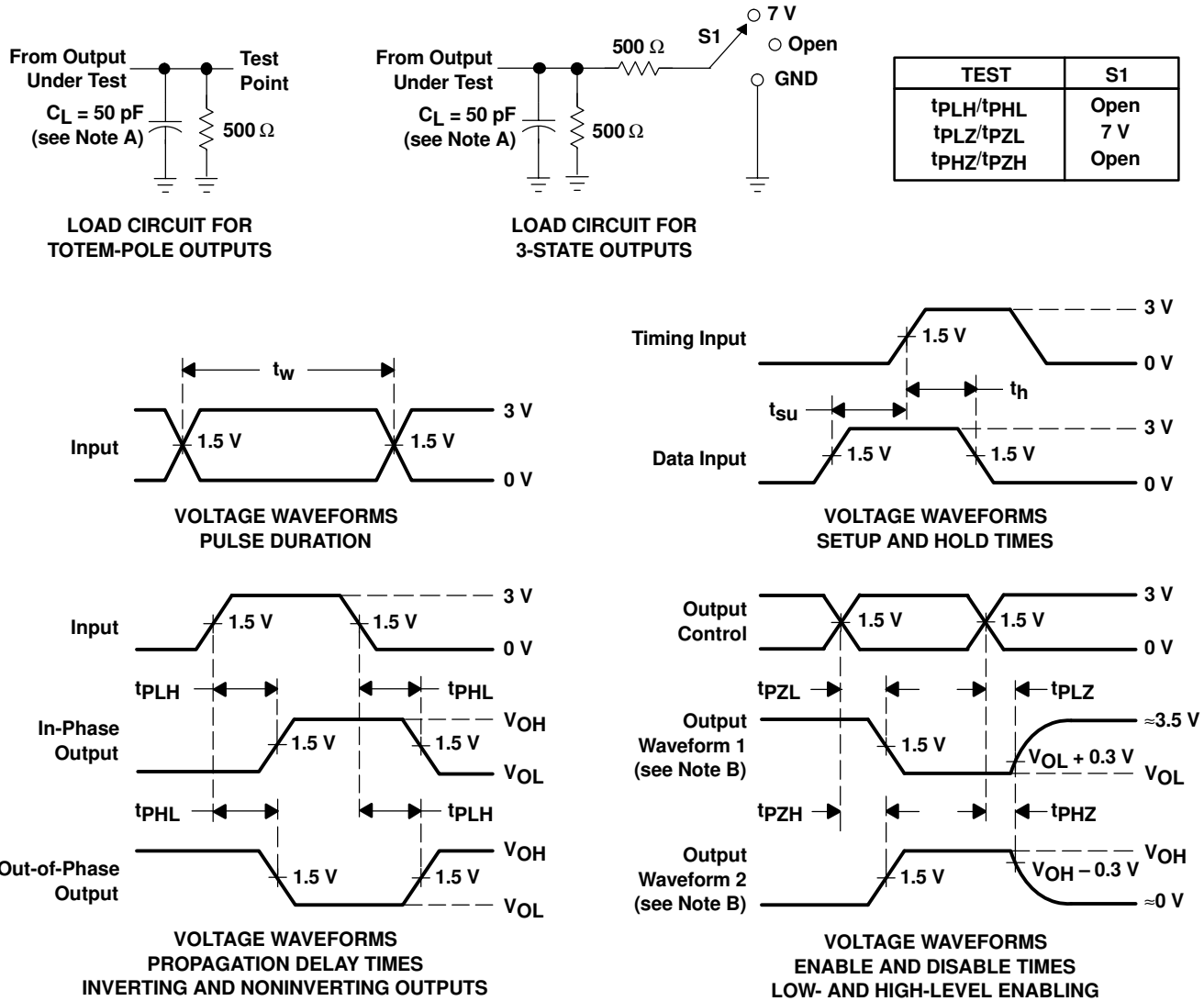

- NOTES: A. C_L includes probe and jig capacitance.
 B. Waveform 1 is for an output with internal conditions such that the output is low except when disabled by the output control. Waveform 2 is for an output with internal conditions such that the output is high except when disabled by the output control.
 C. The outputs are measured one at a time with one input transition per measurement.

Figure 1. Load Circuit and Voltage Waveforms

PACKAGING INFORMATION

Orderable Device	Status (1)	Package Type	Package Drawing	Pins	Package Qty	Eco Plan (2)	Lead/Ball Finish (6)	MSL Peak Temp (3)	Op Temp (°C)	Device Marking (4/5)	Samples
CY74FCT2541ATQCT	ACTIVE	SSOP	DBQ	20	2500	Green (RoHS & no Sb/Br)	NIPDAU	Level-2-260C-1 YEAR	-40 to 85	FCT2541A	Samples
CY74FCT2541ATQCTE4	ACTIVE	SSOP	DBQ	20	2500	Green (RoHS & no Sb/Br)	NIPDAU	Level-2-260C-1 YEAR	-40 to 85	FCT2541A	Samples
CY74FCT2541ATSOC	ACTIVE	SOIC	DW	20	25	Green (RoHS & no Sb/Br)	NIPDAU	Level-1-260C-UNLIM	-40 to 85	FCT2541A	Samples
CY74FCT2541CTQCT	ACTIVE	SSOP	DBQ	20	2500	Green (RoHS & no Sb/Br)	NIPDAU	Level-2-260C-1 YEAR	-40 to 85	FCT2541C	Samples
CY74FCT2541CTSOC	ACTIVE	SOIC	DW	20	25	Green (RoHS & no Sb/Br)	NIPDAU	Level-1-260C-UNLIM	-40 to 85	FCT2541C	Samples
CY74FCT2541TQCT	ACTIVE	SSOP	DBQ	20	2500	Green (RoHS & no Sb/Br)	NIPDAU	Level-2-260C-1 YEAR	-40 to 85	FCT2541	Samples
CY74FCT2541TQCTE4	ACTIVE	SSOP	DBQ	20	2500	Green (RoHS & no Sb/Br)	NIPDAU	Level-2-260C-1 YEAR	-40 to 85	FCT2541	Samples
CY74FCT2541TQCTG4	ACTIVE	SSOP	DBQ	20	2500	Green (RoHS & no Sb/Br)	NIPDAU	Level-2-260C-1 YEAR	-40 to 85	FCT2541	Samples
CY74FCT2541TSOC	ACTIVE	SOIC	DW	20	25	Green (RoHS & no Sb/Br)	NIPDAU	Level-1-260C-UNLIM	-40 to 85	FCT2541	Samples
CY74FCT2541TSOCE4	ACTIVE	SOIC	DW	20	25	Green (RoHS & no Sb/Br)	NIPDAU	Level-1-260C-UNLIM	-40 to 85	FCT2541	Samples
CY74FCT2541TSOCT	ACTIVE	SOIC	DW	20	2000	Green (RoHS & no Sb/Br)	NIPDAU	Level-1-260C-UNLIM	-40 to 85	FCT2541	Samples

(1) The marketing status values are defined as follows:

ACTIVE: Product device recommended for new designs.

LIFEBUY: TI has announced that the device will be discontinued, and a lifetime-buy period is in effect.

NRND: Not recommended for new designs. Device is in production to support existing customers, but TI does not recommend using this part in a new design.

PREVIEW: Device has been announced but is not in production. Samples may or may not be available.

OBSELETE: TI has discontinued the production of the device.

(2) **RoHS:** TI defines "RoHS" to mean semiconductor products that are compliant with the current EU RoHS requirements for all 10 RoHS substances, including the requirement that RoHS substance do not exceed 0.1% by weight in homogeneous materials. Where designed to be soldered at high temperatures, "RoHS" products are suitable for use in specified lead-free processes. TI may reference these types of products as "Pb-Free".

RoHS Exempt: TI defines "RoHS Exempt" to mean products that contain lead but are compliant with EU RoHS pursuant to a specific EU RoHS exemption.

Green: TI defines "Green" to mean the content of Chlorine (Cl) and Bromine (Br) based flame retardants meet JS709B low halogen requirements of <=1000ppm threshold. Antimony trioxide based flame retardants must also meet the <=1000ppm threshold requirement.

- (3) MSL, Peak Temp. - The Moisture Sensitivity Level rating according to the JEDEC industry standard classifications, and peak solder temperature.
- (4) There may be additional marking, which relates to the logo, the lot trace code information, or the environmental category on the device.
- (5) Multiple Device Markings will be inside parentheses. Only one Device Marking contained in parentheses and separated by a "~" will appear on a device. If a line is indented then it is a continuation of the previous line and the two combined represent the entire Device Marking for that device.
- (6) Lead/Ball Finish - Orderable Devices may have multiple material finish options. Finish options are separated by a vertical ruled line. Lead/Ball Finish values may wrap to two lines if the finish value exceeds the maximum column width.

Important Information and Disclaimer:The information provided on this page represents TI's knowledge and belief as of the date that it is provided. TI bases its knowledge and belief on information provided by third parties, and makes no representation or warranty as to the accuracy of such information. Efforts are underway to better integrate information from third parties. TI has taken and continues to take reasonable steps to provide representative and accurate information but may not have conducted destructive testing or chemical analysis on incoming materials and chemicals. TI and TI suppliers consider certain information to be proprietary, and thus CAS numbers and other limited information may not be available for release.

In no event shall TI's liability arising out of such information exceed the total purchase price of the TI part(s) at issue in this document sold by TI to Customer on an annual basis.

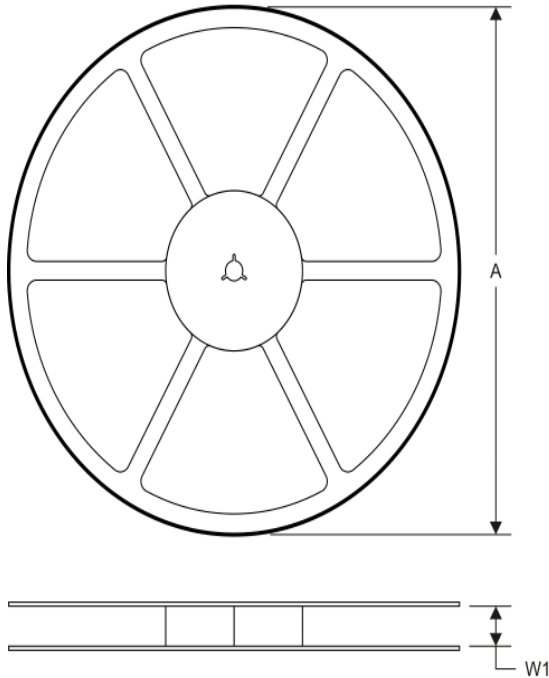
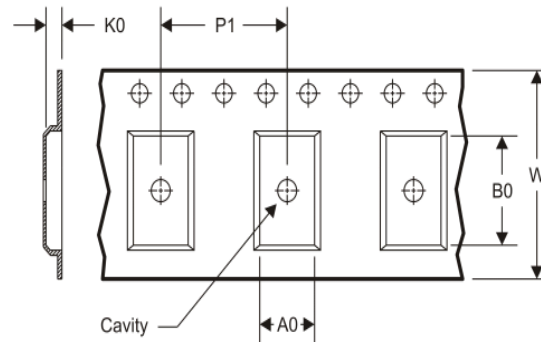
TAPE AND REEL INFORMATION
REEL DIMENSIONS

TAPE DIMENSIONS

A0	Dimension designed to accommodate the component width
B0	Dimension designed to accommodate the component length
K0	Dimension designed to accommodate the component thickness
W	Overall width of the carrier tape
P1	Pitch between successive cavity centers

TAPE AND REEL INFORMATION

*All dimensions are nominal

Device	Package Type	Package Drawing	Pins	SPQ	Reel Diameter (mm)	Reel Width W1 (mm)	A0 (mm)	B0 (mm)	K0 (mm)	P1 (mm)	W (mm)	Pin1 Quadrant
CY74FCT2541ATQCT	SSOP	DBQ	20	2500	330.0	16.4	6.5	9.0	2.1	8.0	16.0	Q1
CY74FCT2541CTQCT	SSOP	DBQ	20	2500	330.0	16.4	6.5	9.0	2.1	8.0	16.0	Q1
CY74FCT2541TQCT	SSOP	DBQ	20	2500	330.0	16.4	6.5	9.0	2.1	8.0	16.0	Q1
CY74FCT2541TSOCT	SOIC	DW	20	2000	330.0	24.4	10.8	13.0	2.7	12.0	24.0	Q1

TAPE AND REEL BOX DIMENSIONS

*All dimensions are nominal

Device	Package Type	Package Drawing	Pins	SPQ	Length (mm)	Width (mm)	Height (mm)
CY74FCT2541ATQCT	SSOP	DBQ	20	2500	367.0	367.0	38.0
CY74FCT2541CTQCT	SSOP	DBQ	20	2500	367.0	367.0	38.0
CY74FCT2541TQCT	SSOP	DBQ	20	2500	367.0	367.0	38.0
CY74FCT2541TSOCT	SOIC	DW	20	2000	367.0	367.0	45.0

DBQ (R-PDSO-G20)

PLASTIC SMALL-OUTLINE PACKAGE

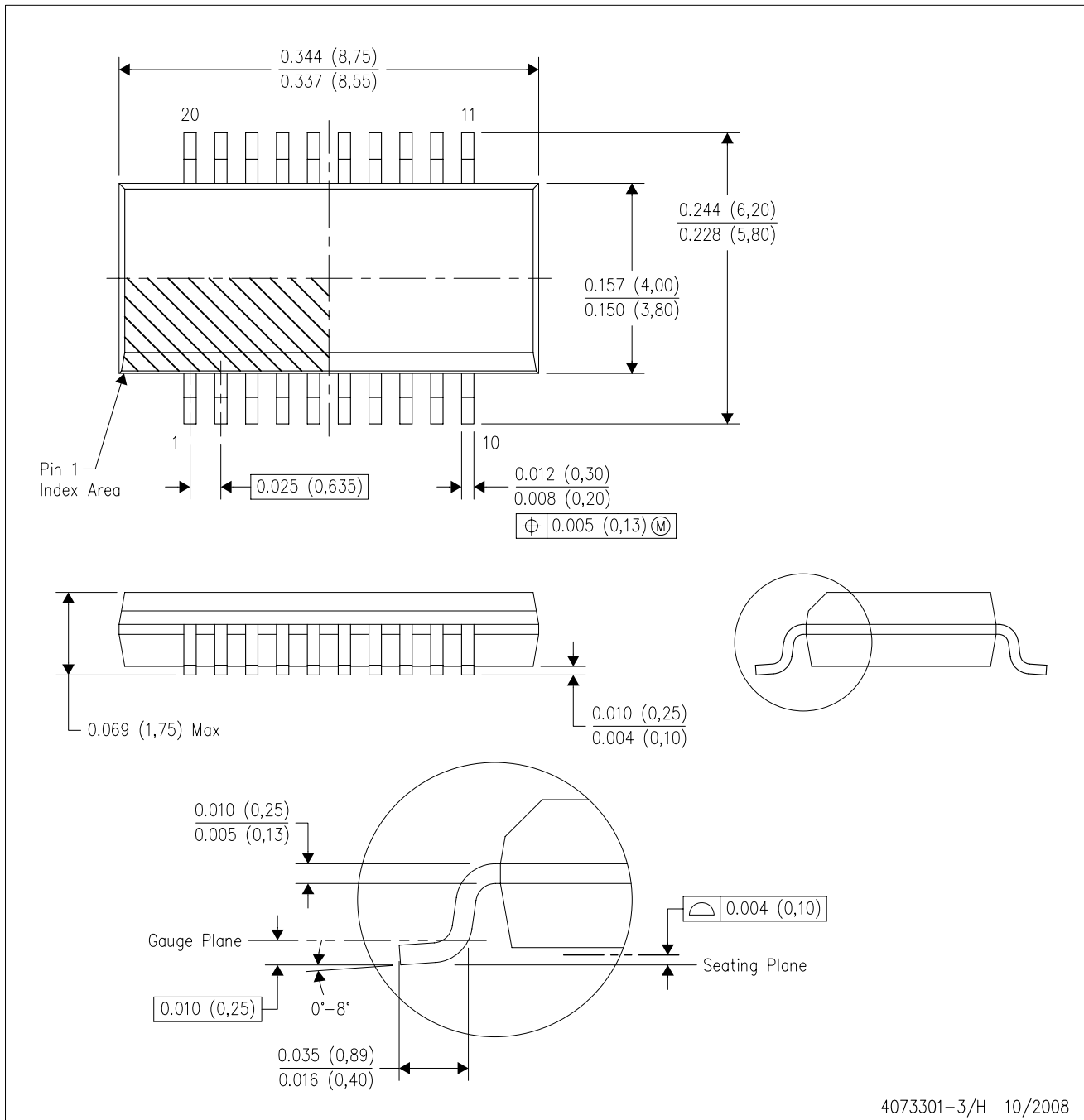

- NOTES:
- A. All linear dimensions are in inches (millimeters).
 - B. This drawing is subject to change without notice.
 - C. Body dimensions do not include mold flash or protrusion not to exceed 0.006 (0,15) per side.
 - D. Falls within JEDEC MO-137 variation AD.

DBQ (R-PDSO-G20)

PLASTIC SMALL OUTLINE PACKAGE

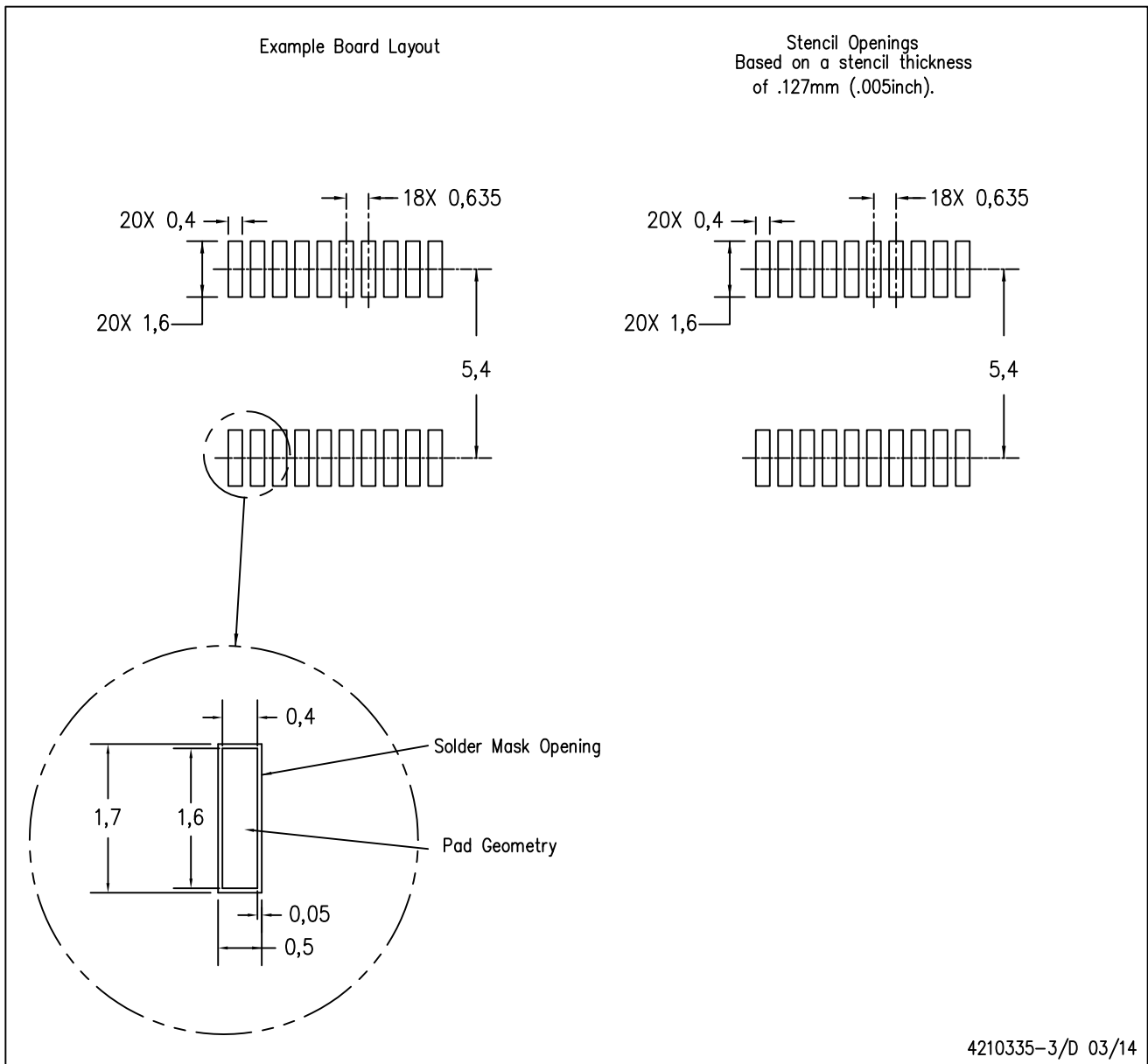

- NOTES:
- A. All linear dimensions are in millimeters.
 - B. This drawing is subject to change without notice.
 - C. Publication IPC-7351 is recommended for alternate designs.
 - D. Laser cutting apertures with trapezoidal walls and also rounding corners will offer better paste release. Customers should contact their board assembly site for stencil design recommendations. Example stencil design based on a 50% volumetric metal load solder paste. Refer to IPC-7525 for other stencil recommendations.

DW0020A



PACKAGE OUTLINE

SOIC - 2.65 mm max height

SOIC

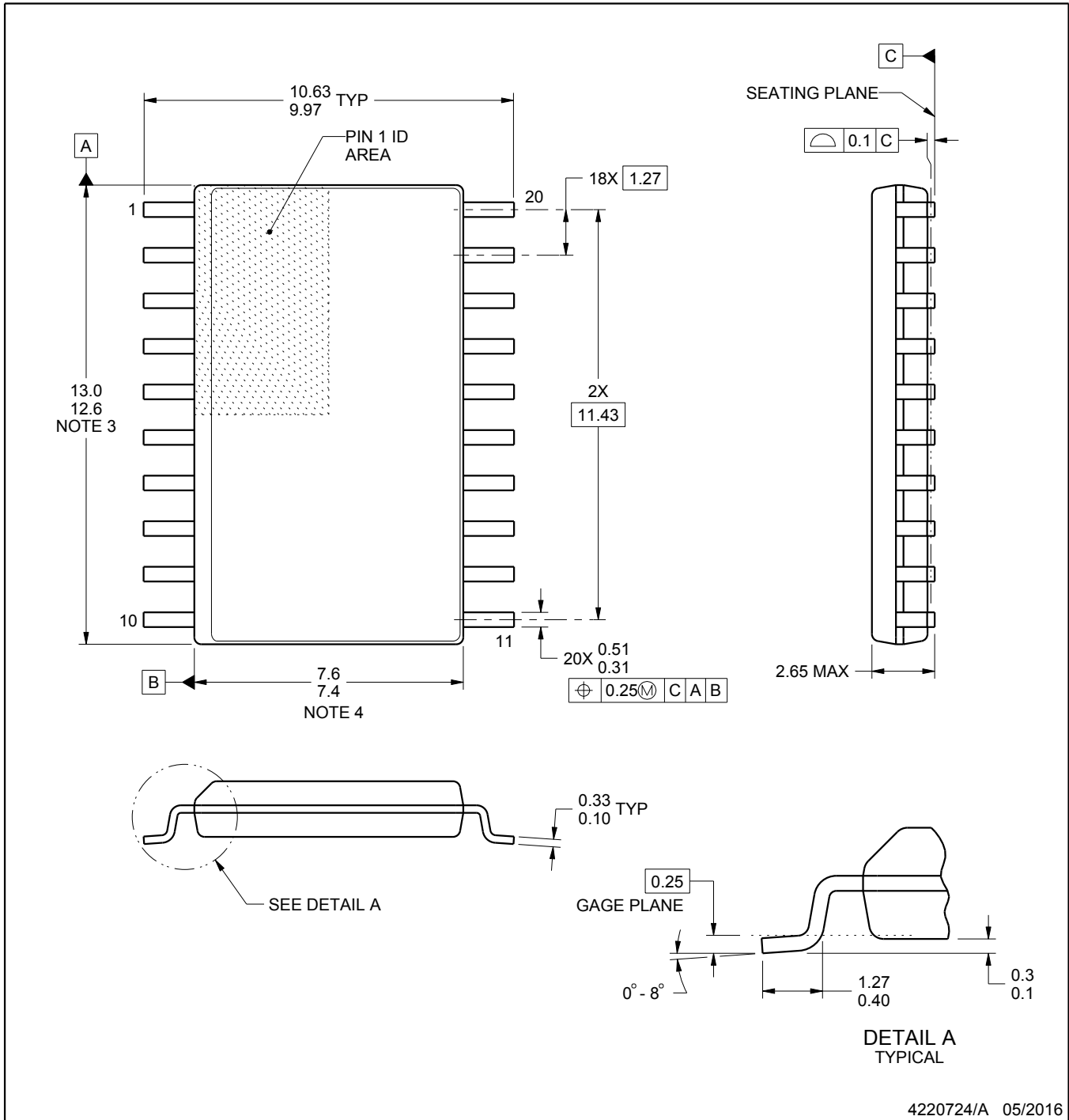

4220724/A 05/2016

NOTES:

1. All linear dimensions are in millimeters. Dimensions in parenthesis are for reference only. Dimensioning and tolerancing per ASME Y14.5M.
2. This drawing is subject to change without notice.
3. This dimension does not include mold flash, protrusions, or gate burrs. Mold flash, protrusions, or gate burrs shall not exceed 0.15 mm per side.
4. This dimension does not include interlead flash. Interlead flash shall not exceed 0.43 mm per side.
5. Reference JEDEC registration MS-013.

EXAMPLE BOARD LAYOUT

DW0020A

SOIC - 2.65 mm max height

SOIC

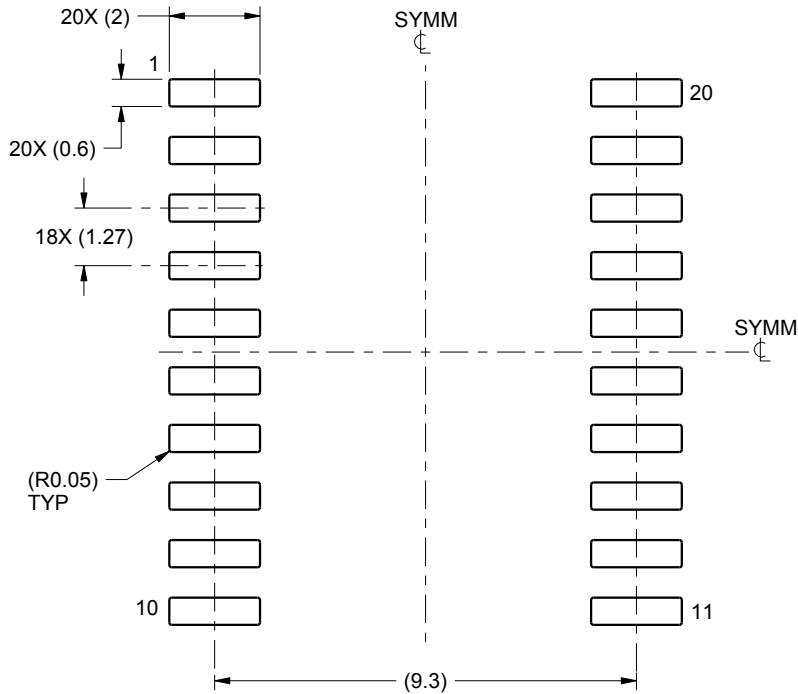

LAND PATTERN EXAMPLE
SCALE:6X

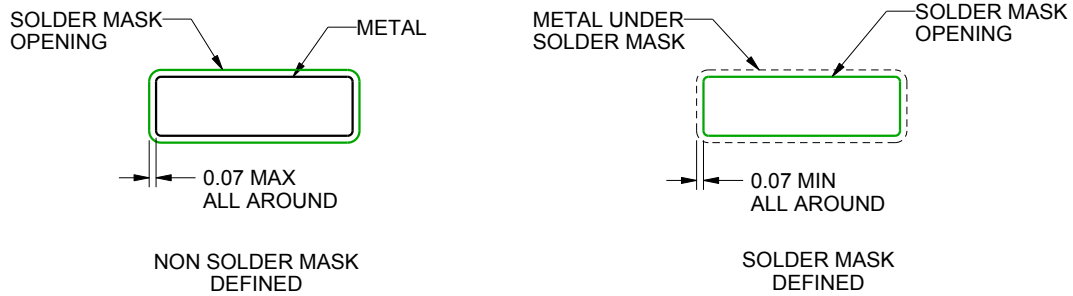

SOLDER MASK DETAILS

4220724/A 05/2016

NOTES: (continued)

- 6. Publication IPC-7351 may have alternate designs.
- 7. Solder mask tolerances between and around signal pads can vary based on board fabrication site.

EXAMPLE STENCIL DESIGN

DW0020A

SOIC - 2.65 mm max height

SOIC

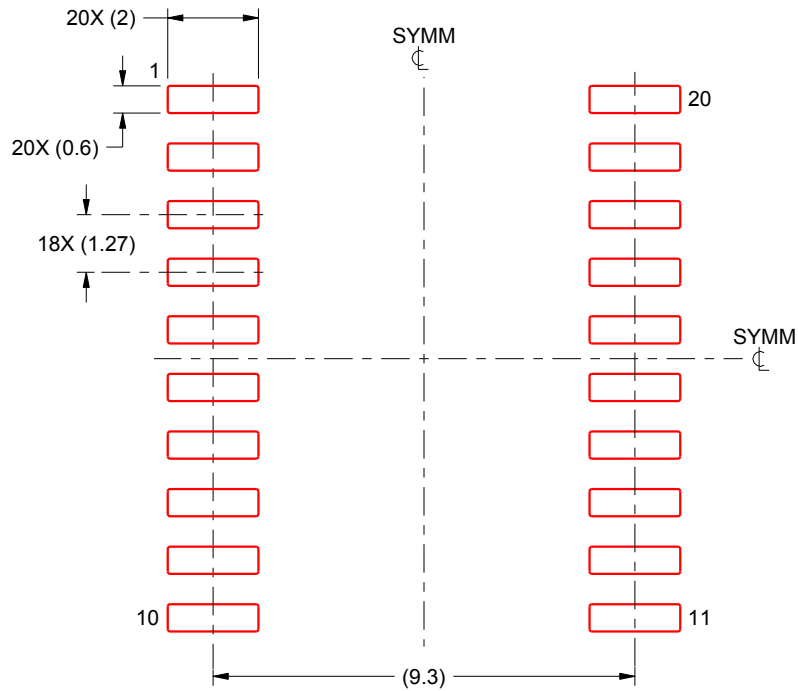

SOLDER PASTE EXAMPLE
BASED ON 0.125 mm THICK STENCIL
SCALE:6X

4220724/A 05/2016

NOTES: (continued)

8. Laser cutting apertures with trapezoidal walls and rounded corners may offer better paste release. IPC-7525 may have alternate design recommendations.
9. Board assembly site may have different recommendations for stencil design.

IMPORTANT NOTICE AND DISCLAIMER

TI PROVIDES TECHNICAL AND RELIABILITY DATA (INCLUDING DATASHEETS), DESIGN RESOURCES (INCLUDING REFERENCE DESIGNS), APPLICATION OR OTHER DESIGN ADVICE, WEB TOOLS, SAFETY INFORMATION, AND OTHER RESOURCES "AS IS" AND WITH ALL FAULTS, AND DISCLAIMS ALL WARRANTIES, EXPRESS AND IMPLIED, INCLUDING WITHOUT LIMITATION ANY IMPLIED WARRANTIES OF MERCHANTABILITY, FITNESS FOR A PARTICULAR PURPOSE OR NON-INFRINGEMENT OF THIRD PARTY INTELLECTUAL PROPERTY RIGHTS.

These resources are intended for skilled developers designing with TI products. You are solely responsible for (1) selecting the appropriate TI products for your application, (2) designing, validating and testing your application, and (3) ensuring your application meets applicable standards, and any other safety, security, or other requirements. These resources are subject to change without notice. TI grants you permission to use these resources only for development of an application that uses the TI products described in the resource. Other reproduction and display of these resources is prohibited. No license is granted to any other TI intellectual property right or to any third party intellectual property right. TI disclaims responsibility for, and you will fully indemnify TI and its representatives against, any claims, damages, costs, losses, and liabilities arising out of your use of these resources.

TI's products are provided subject to TI's Terms of Sale (www.ti.com/legal/termsofsale.html) or other applicable terms available either on ti.com or provided in conjunction with such TI products. TI's provision of these resources does not expand or otherwise alter TI's applicable warranties or warranty disclaimers for TI products.

Mailing Address: Texas Instruments, Post Office Box 655303, Dallas, Texas 75265
Copyright © 2020, Texas Instruments Incorporated