

NOTES:

1. MATERIAL:Halogen Free PLASTIC, HIGH TEMP
UL 94 V-0, COLOR: SEE P/N.
2. MATE WITH 50271 & 50273 SERIES
3. SPEC PLS. REFER TO PS-50276-XXXXX-XXX
4. PART NUMBER

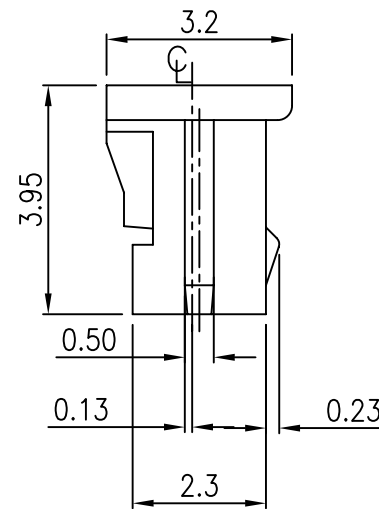

CKT	Dim A	Dim B	Dim C	Dim D
2	4.25	1.25	2.95	0.00
3	5.50	2.50	4.20	0.00
4	6.75	3.75	5.45	2.50
5	8.00	5.00	6.70	3.75
6	9.25	6.25	7.95	5.00
7	10.50	7.50	9.20	6.25
8	11.75	8.75	10.45	7.50
9	13.00	10.00	11.70	8.75
10	14.25	11.25	12.95	10.00
11	15.50	12.50	14.20	11.25
12	16.75	13.75	15.45	12.50
13	18.00	15.00	16.70	13.75
14	19.25	16.25	17.95	15.00
15	20.50	17.50	19.20	16.25
16	21.75	18.75	20.45	17.50
17	23.00	20.00	21.70	18.75
18	24.25	21.25	22.95	20.00
19	25.50	22.50	24.20	21.25
20	26.75	23.75	25.45	22.50

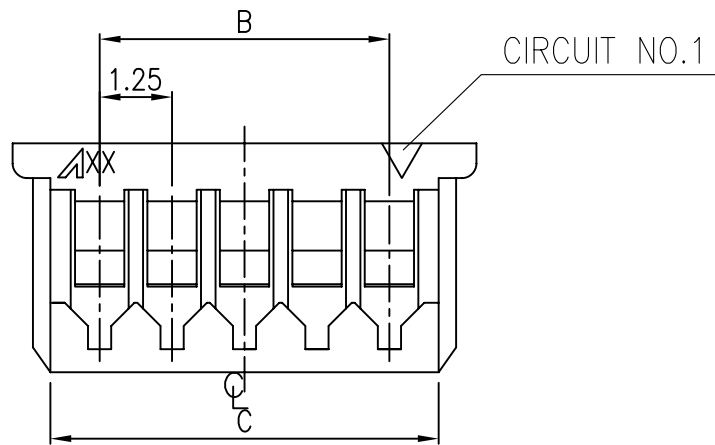
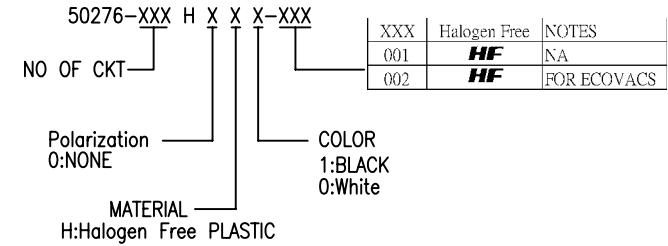
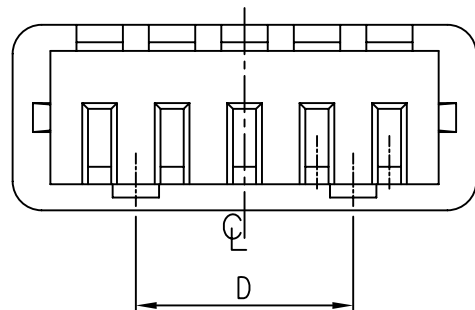

QUALITY SYMBOLS	DRAWN BY	DATE	ACES ELECTRONICS	
MAJOR	ZHOUQUAN	18/01/04		
CRITICAL	CHECKED BY	DATE	1.25mm WTB Housing	
GENERAL TOLERANCES (UNLESS SPECIFIED)	BRAVE	18/01/04		
	APPROVED BY	DATE	SIZE	DWG NO.
	BRAVE	18/01/04	A4	50276-XXXHXXX-XXX
X. ±0.5	UNITS		SCALE	SHEET NO.
.X ±0.25	mm		2:1	1 OF 1
.XX ±0.15	SCALE		REV	PART NO.
.XXX ±0.1	2:1		C	SEE NOTES
ANGLES ±2°				