

LEA-6

u-blox 6 GPS Modules

Data Sheet

Abstract

Technical data sheet describing the cost effective, high-performance u-blox 6 based LEA-6 series of GPS modules, that bring the high performance of the u-blox 6 position engine to the industry standard LEA form factor.

These versatile, stand-alone receivers combine an extensive array of features with flexible connectivity options. Their ease of integration results in fast times-to-market for a wide range of automotive, consumer and industrial applications with strict size and cost requirements.



17.0 x 22.4 x 2.4mm

www.u-blox.com

UBX-14044797 - R13

Document Information	
Title	LEA-6
Subtitle	u-blox 6 GPS Modules
Document type	Data Sheet
Document number	UBX-14044797
Revision, date	R13 17-Feb-2017
Document status	Production Information

Document status information	
Objective Specification	Document contains target values. Revised and supplementary data will be published later.
Advance Information	Document contains data based on early testing. Revised and supplementary data will be published later.
Early Production Information	Document contains data from product verification. Revised and supplementary data may be published later.
Production Information	Document contains the final product specification.

This document applies to the following products:

Product name	Type number	ROM/FLASH version	PCN reference
LEA-6H	LEA-6H-0-002	FW7.03	UBX-TN-11054
LEA-6S	LEA-6S-0-001	ROM7.03	UBX-TN-11059
LEA-6A	LEA-6A-0-001	ROM7.03	UBX-TN-11059
LEA-6R	LEA-6R-0-001	FW DR 2.0	N/A
LEA-6R	LEA-6R-0-002	FW DR 2.02	UBX-13001339
LEA-6T	LEA-6T-0-001	ROM7.03	UBX-TN-11059
	LEA-6T-1-001	FW7.03	
	LEA-6T-2-000	FW6.02	
	LEA-6T-2-001	FW6.04	

u-blox reserves all rights to this document and the information contained herein. Products, names, logos and designs described herein may in whole or in part be subject to intellectual property rights. Reproduction, use, modification or disclosure to third parties of this document or any part thereof without the express permission of u-blox is strictly prohibited.

The information contained herein is provided "as is" and u-blox assumes no liability for the use of the information. No warranty, either express or implied, is given, including but not limited, with respect to the accuracy, correctness, reliability and fitness for a particular purpose of the information. This document may be revised by u-blox at any time. For most recent documents, please visit www.u-blox.com.

Copyright © 2017, u-blox AG.

u-blox® is a registered trademark of u-blox Holding AG in the EU and other countries.



Contents

Contents.....	3
1 Functional description.....	5
1.1 Overview	5
1.2 Product features	5
1.3 GPS performance.....	6
1.4 Block diagram.....	7
1.5 Assisted GPS (A-GPS).....	7
1.6 AssistNow Autonomous	7
1.7 Oscillators.....	7
1.8 GALILEO	7
1.9 GLONASS	8
1.10 Protocols and interfaces	8
1.10.1 UART.....	8
1.10.2 USB.....	8
1.10.3 SPI (LEA-6R).....	9
1.10.4 Display Data Channel (DDC).....	9
1.11 Antenna.....	9
1.11.1 Power Management.....	9
1.11.2 Maximum Performance Mode	9
1.11.3 Eco Mode.....	10
1.11.4 Power Save Mode	10
1.12 Configuration	10
1.12.1 Boot-time configuration (LEA-6A, LEA-6S).....	10
1.12.2 Configuration (LEA-6H, LEA-6R, LEA-6T)	10
1.13 Design-in	10
1.14 Dead Reckoning (LEA-6R).....	11
1.14.1 Supported peripheral components (LEA-6R)	11
1.15 Precision Timing & Raw Data (LEA-6T).....	12
1.15.1 Time mode	12
1.15.2 Timepulse and frequency reference	12
1.15.3 Time mark	12
1.15.4 Raw data.....	12
2 Pin Definition.....	13
2.1 Pin assignment	13
3 Electrical specifications	15
3.1 Absolute maximum ratings	15
3.2 Operating conditions	16
3.3 Indicative power requirements.....	17

4	Mechanical specifications	18
5	Qualification and certification.....	19
5.1	Reliability tests	19
5.2	Approvals	19
6	Product handling & soldering.....	20
6.1	Packaging.....	20
6.1.1	Reels	20
6.1.2	Tapes	21
6.2	Moisture Sensitivity Levels.....	22
6.3	Reflow soldering.....	22
6.4	ESD handling precautions	22
7	Default settings.....	23
8	Labeling and ordering information.....	24
8.1	Product labeling.....	24
8.2	Explanation of codes.....	24
8.3	Ordering information.....	24
	Related documents.....	25
	Revision history.....	25
	Contact.....	26

1 Functional description

1.1 Overview

The LEA-6 module series is a family of stand-alone GPS receivers featuring the high performance u-blox 6 positioning engine. These versatile receivers feature an extensive and flexible range of functionality, connectivity and cost savings options. LEA-6 modules maintain the industry standard 17.0 x 22.4mm form factor of the LEA-5 series and have been designed to allow simple migration. Their ease of integration results in reduced costs and short time to market for a wide range of automotive, consumer and industrial applications.

The 50-channel u-blox 6 positioning engine boasts a Time-To-First-Fix (TTFF) of less than 1 second. The dedicated acquisition engine, with over 2 million correlators, is capable of massive parallel time/frequency space searches, enabling it to find satellites instantly. Innovative design and technology suppresses interference sources and mitigates multipath effects, giving LEA-6 GPS receivers excellent navigation performance even in the most challenging environments.

LEA-6 allows simple integration with u-blox wireless modules.

1.2 Product features

Model	Type				Supply		Interfaces				Features						
	Standalone GPS	GLONASS	Timing & Raw Data	Dead Reckoning	1.75 V - 2.0 V	2.7 V - 3.6 V	UART	USB	SPI	DDC (I ² C compliant)	Programmable (Flash) FW update	TCXO	RTC crystal	Antenna supply and supervisor	Configuration pins	Timepulse	External interrupt/Wakeup
LEA-6H	•	R			•		•	•		•	•	•	•	•		1	•
LEA-6S	•				•		•	•		•		•	•	•	1	1	•
LEA-6A	•				•		•	•		•		•	•	•	1	1	•
LEA-6R	•			•	•		•	•	S			•	•			1	•
LEA-6T-0	•		•		•		•	•		•	F	•	•	•		2	•
LEA-6T-1	•		•		•		•	•		•	•	•	•	•		2	•
LEA-6T-2	•		•		•		•	•		•	•	•	•	•		1	•

F = Serial Flash memory available for storage of configuration
S = SPI available for communication with external sensors only

R = HW GLONASS ready, firmware upgrade required.

Table 1: Features of the LEA-6 Series



All LEA-6 modules are based on GPS chips qualified according to AEC-Q100. See Chapter 5.1 for further information.

1.3 GPS performance

Parameter	Specification			
Receiver type	50 Channels GPS L1 frequency, C/A Code GALILEO Open Service capable ¹ GLONASS FDMA ¹ SBAS: WAAS, EGNOS, MSAS			
Time-To-First-Fix ²		LEA-6H/LEA-6S/ LEA-6T-0/LEA-6T-1	LEA-6A/ LEA-6R	LEA-6T-2
	Cold Start (without aiding)	26 s	27 s	28 s
	Warm Start (without aiding)	26 s	27 s	28 s
	Hot Start (without aiding)	1 s	1 s	1 s
	Aided Starts ³	1 s	3 s	1 s
Sensitivity ⁴		LEA-6H/LEA-6S/ LEA-6T-0/LEA-6T-1	LEA-6A/ LEA-6R	LEA-6T-2
	Tracking & Navigation	-162 dBm	-162 dBm	-160 dBm
	Reacquisition	-160 dBm	-160 dBm	-160 dBm
	Cold Start (without aiding)	-148 dBm	-147 dBm	-147dBm
Max. Navigation update rate		LEA-6A/ LEA-6S/ LEA-6T-0	LEA-6H/LEA-6T-1/LEA-6T-2	LEA-6R
		5 Hz	2 Hz	1 Hz
Horizontal position accuracy ⁵	Without aiding	2.5 m		
	SBAS	2.0 m		
Configurable Timepulse frequency range		LEA-6H/ LEA-6S/ LEA-6A/ LEA-6R	LEA-6T	
		0.25 Hz to 1 kHz	0.25 Hz to 10 MHz	
Accuracy for Timepulse signal ⁶	RMS	30 ns		
	99%	<60 ns		
	Compensated ⁷	15 ns		
Velocity accuracy ⁶		0.1 m/s		
Heading accuracy ⁶		0.5 degrees		
Operational Limits	Dynamics	≤ 4 g		
	Altitude ⁸	50,000 m		
	Velocity ⁸	500 m/s		

Table 2: LEA-6 GPS performance

¹ Via FW update on LEA-6H

² All satellites at -130 dBm

³ Dependant on aiding data connection speed and latency

⁴ Demonstrated with a good active antenna

⁵ CEP, 50%, 24 hours static, -130 dBm, SEP: < 3.5 m

⁶ Under good GPS signal conditions

⁷ Quantization error information can be used with LEA-6T to compensate the granularity related error of the timepulse signal

⁸ Assuming Airborne < 4g platform

1.4 Block diagram

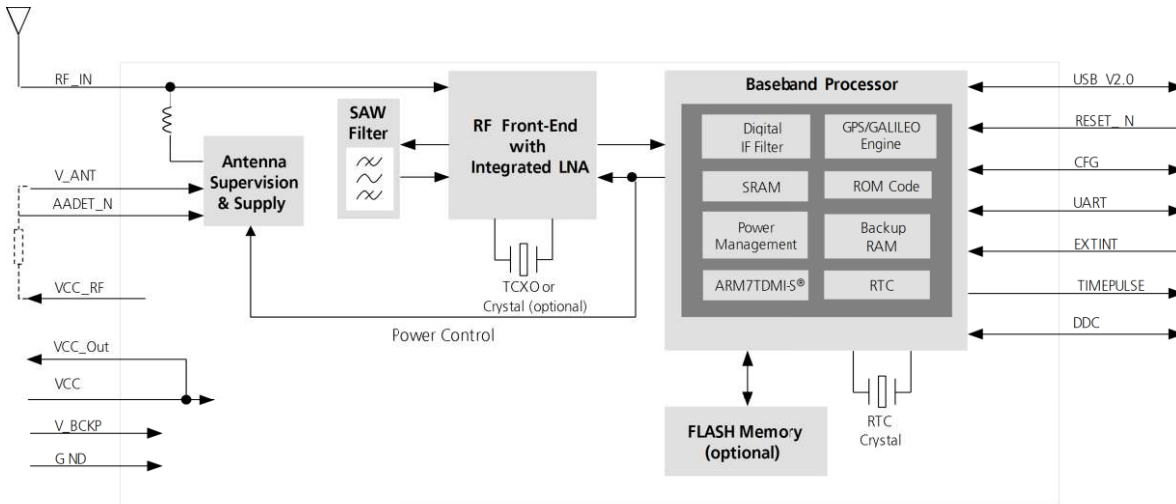

Figure 1 Block diagram (For available options refer to the product features table in section 1.2.)

1.5 Assisted GPS (A-GPS)

Supply of aiding information like ephemeris, almanac, approximate previous position and time, satellite status and an optional time synchronization signal will reduce time to first fix significantly and improve the acquisition sensitivity. All LEA-6 modules support the u-blox AssistNow Online and AssistNow Offline A-GPS services⁹ and are OMA SUPL compliant.

1.6 AssistNow Autonomous

AssistNow Autonomous provides functionality similar to Assisted-GPS without the need for a host or external network connection. Based on previously broadcast satellite ephemeris data downloaded to and stored by the GPS receiver, AssistNow Autonomous automatically generates accurate satellite orbital data ("AssistNow Autonomous data") that is usable for future GPS position fixes. AssistNow Autonomous data is reliable for up to 3 days after initial capture.

u-blox' AssistNow Autonomous benefits are:

- Faster position fix
- No connectivity required
- Complementary with AssistNow Online and Offline services
- No integration effort, calculations are done in the background



For more details see the u-blox 6 Receiver Description including Protocol Specification [2].

1.7 Oscillators

LEA-6 GPS modules are available in Crystal and TCXO versions. The TCXO allows accelerated weak signal acquisition, enabling faster start and reacquisition times.

1.8 GALILEO

When GALILEO-L1 signals become available, LEA-6H receivers will be capable of receiving and processing them via a firmware upgrade. The ability to receive and track GALILEO satellite signals will result in higher coverage, improved reliability and better accuracy.

⁹ AssistNow Offline requires external memory on the host for LEA-6S, LEA-6A, and LEA-6T-0

1.9 GLONASS

The Russian GLONASS satellite system is an alternative system to the US-based Global Positioning System (GPS). LEA-6H modules are GLONASS ready and are capable of receiving and processing GLONASS signals via a firmware upgrade. For more information about GLONASS and implementation see the u-blox GPS Compendium [4] and the GLONASS & GPS HW Designs Application Note [5].

1.10 Protocols and interfaces

Protocol	Type
NMEA	Input/output, ASCII, 0183, 2.3 (compatible to 3.0)
UBX	Input/output, binary, u-blox proprietary
RTCM	Input, 2.3

Table 3: Available protocols

All listed protocols are available on UART, USB and DDC. For specification of the various protocols see the u-blox 6 Receiver Description including Protocol Specification [2].

LEA-6 modules support a number of peripheral interfaces for serial communication. The embedded firmware uses these interfaces according to their respective protocol specifications. For specific applications, the firmware also supports the connection of external memories.

1.10.1 UART

LEA-6 modules include one configurable UART interface for serial communication (for information about configuration see section 1.12).

1.10.2 USB

LEA-6 modules provide a USB version 2.0 FS (Full Speed, 12Mbit/s) interface as an alternative to the UART. The pull-up resistor on USB_DP is integrated to signal a full-speed device to the host. The VDDUSB pin supplies the USB interface.

u-blox provides a Microsoft® certified USB driver for Windows XP, Windows Vista and Windows 7 operating systems.

Operating System	Support level
Windows XP	Certified
Windows Vista	Certified
Windows 7	Certified

Table 4: Operating systems supported by USB driver

1.10.3 SPI (LEA-6R)

LEA-6R includes a Serial Peripheral Interface (SPI) for connecting external sensors. The interface can be operated in SPI master mode only. Two chip select signals are available to select external slaves.

LEA-6R default SPI clock is 870 kHz. As LEA-4R default value is 460 kHz, migrating from LEA-4R to LEA-6R will require a bandwidth verification of the SPI circuits.

1.10.4 Display Data Channel (DDC)

The I²C compatible DDC interface can be used either to access external devices with a serial interface or to interface with a host CPU. It is capable of master and slave operation. DDC is not available with LEA-6R. The DDC interface is I²C Standard Mode compliant. For timing parameters consult the I²C standard.



The DDC Interface supports serial communication with u-blox wireless modules. See the specification of the applicable wireless module to confirm compatibility.



The maximum bandwidth is 100kbit/s.

1.10.4.1 External serial EEPROM

LEA-6A and LEA-6S modules allow an optional external serial EEPROM to be connected to the DDC interface. This can be used to store Configurations permanently.



For more information see the LEA-6/NEO-6/MAX-6 Hardware Integration Manual [1].

1.11 Antenna

LEA-6 modules are designed for use with passive and active antennas.

An antenna supervisor is available with all LEA-6 Modules. In the default operation mode the antenna supervisor is activated and enables the receiver to detect short circuits at the active antenna by checking the bias voltage level and can shut down the voltage bias immediately. A series resistor is needed in front of the **V_ANT** input. UBX and NMEA messages are provided to report the condition of the antenna supply. Open circuit detection can also be supported with an additional external circuit. For details, please refer to the LEA-6/NEO-6/MAX-6 Hardware Integration Manual [1].

Parameter	Specification	
Antenna Type	Passive and active antenna	
Active Antenna Recommendations	Minimum gain	15 dB (to compensate signal loss in RF cable)
	Maximum gain	50 dB
	Maximum noise figure	1.5 dB

Table 5: Antenna specifications

1.11.1 Power Management

u-blox receivers support different power modes. These modes represent strategies of how to control the acquisition and tracking engines in order to achieve either the best possible performance or good performance with reduced power consumption.



For more information about power management strategies, see the u-blox 6 Receiver Description including Protocol Specification [2].

1.11.2 Maximum Performance Mode

During a Cold start, a receiver in Maximum Performance Mode continuously deploys the acquisition engine to search for all satellites. Once the receiver has a position fix (or if pre-positioning information is available), the acquisition engine continues to be used to search for all visible satellites that are not being tracked.

1.11.3 Eco Mode

During a Cold start, a receiver in Eco Mode works exactly as in Maximum Performance Mode. Once a position can be calculated and a sufficient number of satellites are being tracked, the acquisition engine is powered off resulting in significant power savings. The tracking engine continuously tracks acquired satellites and acquires other available or emerging satellites.

Note that even if the acquisition engine is powered off, satellites continue to be acquired.

1.11.4 Power Save Mode

Power Save Mode (PSM) allows a reduction in system power consumption by selectively switching parts of the receiver on and off.

Power Save mode is not available with LEA-6R.

1.12 Configuration

1.12.1 Boot-time configuration (LEA-6A, LEA-6S)

LEA-6A and LEA-6S modules provide **CFG_COM1** for boot-time configuration. This pin becomes effective immediately after start-up. Once the module has started, the configuration settings can be modified with UBX configuration messages. The modified settings remain effective until power-down or reset. If these settings have been stored in battery-backup RAM, then the modified configuration will be retained, as long as the backup battery supply is not interrupted.

UART settings can be configured as seen in Table 6 with the **CFG_COM1** pin. Default settings in bold.

CFG_COM1	Protocol	Messages	UARTBaud rate
1	NMEA	GSV, RMC, GSA, GGA, GLL, VTG, TXT	9600
0	NMEA	GSV ¹⁰ , RMC, GSA, GGA, VTG, TXT	4800

Table 6: Supported CFG_COM1 settings (LEA-6A, LEA-6S)

1.12.2 Configuration (LEA-6H, LEA-6R, LEA-6T)

With the LEA-6H, LEA-6R and LEA-6T, configuration settings modified with UBX configuration messages can be saved permanently. In this case the modified settings remain effective even after power-down and don't require backup battery supply.

LEA-6T-0 includes a serial Flash memory for storage of configuration. Saving full configurations might take several seconds to store on LEA-6T-0. Do not power down the Module before receiving the acknowledge.

For more information, see the u-blox 6 Receiver Description including Protocol Specification [2].

1.13 Design-in

In order to obtain the necessary information to conduct a proper design-in, u-blox strongly recommends consulting the LEA-6/NEO-6/MAX-6 Hardware Integration Manual [1].

¹⁰ Every 5th fix.

1.14 Dead Reckoning (LEA-6R)

LEA-6R receivers supplement the GPS information with an incoming signal from a gyroscope (turn rate sensor) and odometer pulses to do dead reckoning navigation through periods of poor GPS reception. Depending on the quality of the available GPS signals, the LEA-6R uses an algorithm specially developed by u-blox in order to compute the next positions accurately by using an automatically weighted average of the GPS and sensor inputs. This provides precise navigation in locations with no or impaired GPS reception, for example in tunnels, indoor car parks and deep urban canyons.

The LEA-6R is a low power dead reckoning GPS receiver module. The LEA-6R is the ideal solution for applications requiring accurate, reliable positioning, all of the time.

The LEA-6R includes a front-end LNA.

1.14.1 Supported peripheral components (LEA-6R)

The LEA-6R supports the following peripheral components:

A/D converters with SPI interface	digital temperature sensors with SPI interface
Linear Technology, LTC1860, 12-bit A/D converter	National Semiconductors, LM70, precision: 10 bits plus sign

Table 7: Supported peripheral components

Gyroscopes should at least meet the requirements listed below:

Parameter	Specification
Supply Voltage	5.0 V \pm 0.25 V
Zero Point	2.5 V \pm 0.4 V
Sensitivity	25 mV/°/s \pm 5 mV/°/s
Dynamic Range	\pm 60°/s to \pm 125°/s
Linearity	\pm 0.5% (Full scale)
Recommended operating temperature range	-40°C to +85°C

Table 8: Required Specifications for Gyroscopes

Gyroscopes with a sensitivity of lower than 20 mV/°/s may work but the performance will be degraded. For this reason u-blox does not recommend using gyroscopes with a lower sensitivity.

For implementation details as well as a list of supported gyroscopes that u-blox is currently aware of, or for more information about Dead Reckoning and other special features of the LEA-6R refer to the LEA-6/NEO-6/MAX-6 Hardware Integration Manual [1] and the u-blox 6 Receiver Description including Protocol Specification [2].

1.15 Precision Timing & Raw Data (LEA-6T)

Timing and Raw data features are available in three Module versions, the LEA-6T-0, LEA-6T-1 and LEA-6T-2. All are pin-compatible Modules. The LEA-6T-1 and LEA-6T-2 include internal Flash memories for firmware updates.

1.15.1 Time mode

LEA-6T provides a special Time Mode to provide higher timing accuracy. The LEA-6T is designed for use with stationary antenna setups. The Time Mode features three different settings described in Table 9: Disabled, Survey-In and Fixed Mode. For optimal performance entering the position of the antenna (when known) is recommended as potential source of errors will be reduced.

Time Mode Settings	Description
Disabled	Standard PVT operation
Survey-In	The GPS receiver computes the average position over an extended time period until a predefined maximum standard deviation has been reached. Afterwards the receiver will be automatically set to Fixed Mode and the timing features will be activated.
Fixed Mode	In this mode, a fixed 3D position and known standard deviation is assumed and the timing features are activated. Fixed Mode can either be activated directly by feeding pre-defined position coordinates (ECEF - Earth Center Earth Fixed format) or by performing a Survey-In. In Fixed mode, the timing errors in the TIMEPULSE signal which otherwise result from positioning errors are eliminated. Single-satellite operation is supported. For details, please refer to the u-blox 6 Receiver Description including Protocol Specification [2].

Table 9: Time mode settings

1.15.2 Timepulse and frequency reference

LEA-6T-0 and LEA-6T-1 not only feature the new u-blox 6 engine with its extra acquisition sensitivity, they also comes with a 2nd timepulse output, which can be configured from 0.25 Hz up to 10 MHz. One timepulse can be used for time synchronization (i.e. 1 pulse per second), while the 2nd timepulse can be used with LEA-6T as a reference frequency in the MHz range. A timepulse in the MHz range provides excellent long-term frequency accuracy and stability. This brings cost savings for LEA-6T customers since it is no longer necessary to generate an additional reference frequency with their circuitry. (LEA-6T-2 supports only a single timepulse output.)

1.15.3 Time mark

LEA-6T can be used for precise time measurements with sub-microsecond resolution using the external interrupt (EXTINT0). Rising and falling edges of these signals are time-stamped to the GPS or UTC time and counted. The Time Mark functionality can be enabled with the UBX-CFG-TM2 message

For details, please refer to the u-blox 6 Receiver Description including Protocol Specification [2].

1.15.4 Raw data

Raw data output is supported at an update rate of 5 Hz on the LEA-6T-0 and 2 Hz on the LEA-6T-1 and LEA-6T-2. The UBX-RXM-RAW message includes carrier phase with half-cycle ambiguity resolved, code phase and Doppler measurements, which can be used in external applications that offer precision positioning, real-time kinematics (RTK) and attitude sensing.

2 Pin Definition

2.1 Pin assignment



Figure 2 LEA-6 Pin Assignment

Pin Nr.	Module	Name	I/O	Description
1	LEA-6A, LEA-6S, LEA-6H, LEA-6T	SDA2	I/O	DDC Data
	LEA-6R	SPI_MOSI	O	SPI MOSI
2	LEA-6A, LEA-6S, LEA-6H, LEA-6T	SCL2	I/O	DDC Clock
	LEA-6R	SPI_MISO	I	SPI MISO
3	All	TxD1	O	Serial Port 1
4	All	RxD1	I	Serial Port 1
5	All	NC		Not Connected
6	All	VCC	I	Supply voltage
7	All	GND	I	Ground (digital)
8	All	VCC_OUT	O	Output voltage
9	LEA-6A, LEA-6S	CFG_COM1	I	Configuration Pin
	LEA-6H, LEA-6T-2	NC		Not Connected
	LEA-6R	SPI_SCS2_N	O	SPI Chip Select 2
	LEA-6T-0, LEA-6T-1	TIMEPULSE2	O	2 nd Timepulse (1PPS)
10	All	RESET_N	I	External Reset
11	All	V_BCKP	I	Backup voltage supply
12	All	Reserved	I	Do not drive low
13	All	GND	I	Ground
14	All	GND	I	Ground
15	All	GND	I	Ground
16	All	RF_IN	I	GPS signal input
17	All	GND	I	Ground
18	All	VCC_RF	O	Output Voltage RF section
19	All	V_ANT	I	Antenna Bias voltage
20	All	AADET_N	I	Active Antenna Detect

Pin Nr.	Module	Name	I/O	Description
21	LEA-6A, LEA-6S, LEA-6H, LEA-6T	Reserved		Not Connected
	LEA-6R	FWD	I	Direction indication (1 = forward)
22	LEA-6A, LEA-6S, LEA-6H, LEA-6T	Reserved		Not Connected
	LEA-6R	SPI_SCS1_N	O	SPI Chip Select 1
23	LEA-6A, LEA-6S, LEA-6H, LEA-6T	Reserved		Not Connected
	LEA-6R	SPI_SCK	O	SPI Clock
24	All	VDDUSB	I	USB Supply
25	All	USB_DM	I/O	USB Data
26	All	USB_DP	I/O	USB Data
27	LEA-6A, LEA-6S, LEA-6H, LEA-6T	EXTINT0	I	External Interrupt Pin
	LEA-6R	SPEED	I	Odometer Speedpulses
28	All	TIMEPULSE	O	Timepulse (1PPS)

Table 10: Pinout

Pins designated Reserved should only be used with caution. For more information about Pinouts see the LEA-6/NEO-6/MAX-6 Hardware Integration Manual [1].

3 Electrical specifications

3.1 Absolute maximum ratings

Parameter	Symbol	Condition	Min	Max	Units
Power supply voltage	VCC		-0.5	3.6	V
Backup battery voltage	V_BCKP		-0.5	3.6	V
USB supply voltage	VDDUSB		-0.5	3.6	V
Input pin voltage	Vin		-0.5	3.6	V
	Vin_usb		-0.5	VDDUSB	V
DC current through any digital I/O pin (except supplies)	Ipin			10	mA
VCC_RF output current	ICC_RF			100	mA
Input power at RF_IN	Prfin	source impedance = 50 Ω , continuous wave		15	dBm
Antenna bias voltage	V_ANT			6	V
Antenna bias current	I_ANT			100	mA
Storage temperature	Tstg		-40	85	$^{\circ}\text{C}$

Table 11: Absolute maximum ratings



GPS receivers are Electrostatic Sensitive Devices (ESD) and require special precautions when handling. For more information see section 6.4.



Stressing the device beyond the “Absolute Maximum Ratings” may cause permanent damage. These are stress ratings only. The product is not protected against overvoltage or reversed voltages. If necessary, voltage spikes exceeding the power supply voltage specification, given in table above, must be limited to values within the specified boundaries by using appropriate protection diodes. For more information see the *LEA-6/NEO-6/MAX-6 Hardware Integration Manual* [1].

3.2 Operating conditions



All specifications are at an ambient temperature of 25°C.

Parameter	Symbol	Module	Min	Typ	Max	Units	Condition
Power supply voltage	VCC	All	2.7	3.0	3.6	V	
Supply voltage USB	VDDUSB	All	3.0	3.3	3.6	V	
Backup battery voltage	V_BCKP	All	1.4		3.6	V	
Backup battery current	I_BCKP	All		22		µA	V_BCKP = 1.8V, VCC = 0V
Input pin voltage range	V _{in}	All	0		VCC	V	
Digital IO Pin Low level input voltage	V _{il}	All	0		0.2*VCC	V	
Digital IO Pin High level input voltage	V _{ih}	All	0.7*VCC		VCC	V	
Digital IO Pin Low level output voltage	V _{ol}	All			0.4	V	I _{ol} =4mA
Digital IO Pin High level output voltage	V _{oh}	All	VCC -0.4V			V	I _{oh} =4mA
AADET_N low level input voltage	V _{il}	All		<0.6		V	V _o =2.1V
AADET_N high level input voltage	V _{ih}	All		>0.75		V	V _o =0.6V
USB_DM, USB_DP	V _{inU}	All	Compatible with USB with 22 Ohms series resistance				
V_ANT antenna bias voltage	V_ANT	All	2.7		5.5	V	I _{ANT} < -50 mA
Antenna bias voltage drop	V_ANT_DROP	All		0.1		V	ICC_RF =50mA
VCC_RF voltage	VCC_RF	All		VCC-0.1		V	
VCC_RF output current	ICC_RF	All			50	mA	
Antenna gain	G _{ant}	All			50	dB	
Receiver Chain Noise Figure	NF _{tot}	LEA-6S/ LEA-6A/ LEA-6T/ LEA-6H		3.2		dB	
		LEA-6R		1.5		dB	
Operating temperature	T _{opr}	All	-40		85	°C	

Table 12: Operating conditions



Operation beyond the specified operating conditions can affect device reliability.

3.3 Indicative power requirements

Table 13 lists examples of the total system supply current for a possible application.

Parameter	Symbol	Module	Min	Typ	Max	Units	Condition
Peak supply current ¹¹	Iccp	All			67	mA	VCC = 3.6V
	Icc Acquisition	All		47 ¹³		mA	VCC = 3.0V
Average supply current ¹²	Icc Tracking (Max Performance mode)	LEA-6H / LEA-6S / LEA-6T		41 ¹⁴		mA	VCC = 3.0V
		LEA-6A/ LEA-6R		40 ¹⁴		mA	VCC = 3.0V
	Icc Tracking (Eco mode)	LEA-6H / LEA-6S / LEA-6T		39 ¹⁴		mA	VCC = 3.0V
		LEA-6A/ LEA-6R		38 ¹⁴		mA	VCC = 3.0V
	Icc Tracking ¹⁵ (Power Save Mode)	LEA-6S		12 ¹⁴		mA	VCC = 3.0V
		LEA-6H		12 ¹⁴		mA	VCC = 3.0V
	LEA-6A		11 ¹⁴		mA	VCC = 3.0V	

Table 13: Indicative power requirements



Values in Table 13 are provided for customer information only as an example of typical power requirements. Values are characterized on samples, actual power requirements can vary depending on FW version used, external circuitry, number of SVs tracked, signal strength, type of start as well as time, duration and conditions of test.

¹¹ Use this figure to dimension maximum current capability of power supply. Measurement of this parameter with 1 Hz bandwidth.

¹² Use this figure to determine required battery capacity.

¹³ >8 SVs in view, CNo >40 dBHz, current average of 30 sec after cold start.

¹⁴ with strong signals (>130 dBm), all visible satellites are tracked (>7 SV). For Cold Starts typical 12 min after First Fix. For Hot Starts typical 15 sec after First Fix.

¹⁵ Cyclic operation: Update rate 1 s.

4 Mechanical specifications

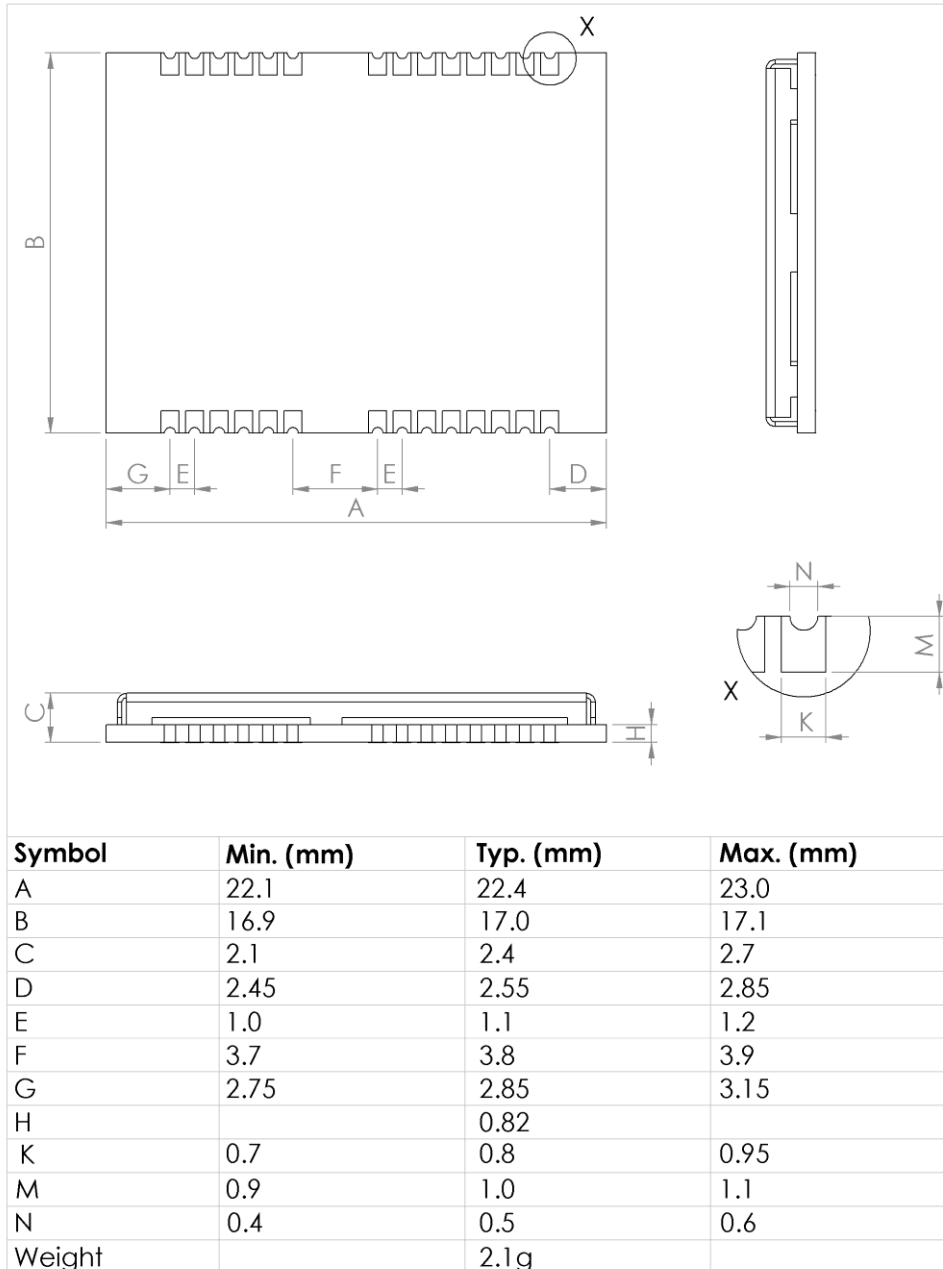

Figure 3: Dimensions

For information regarding the Paste Mask and Footprint see the LEA-6/NEO-6/MAX-6 Hardware Integration Manual [1].

5 Qualification and certification

5.1 Reliability tests



All LEA-6 modules are based on GPS chips qualified according to AEC-Q100.

Tests for product family qualifications according to ISO 16750 "Road vehicles - Environmental conditions and testing for electrical and electronic equipment", and appropriate standards (see Table 14).

Test	Reference	Test Conditions
Temperature step test	ISO16750-4 IEC60068-2-1 IEC60068-2-2	Function tests at stable temperature. The temperature has to decrease in 5K steps from RT to -40°C followed by increase to +85°C in 5K steps.
Temperature cycling	IEC60068-2-14 Na	-40°C / +125°C, 300 cycles, air to air No function
Dry heat I ("desert")	IEC60068-2-2	+60°C / 5%rH, Toper max, Vccmax, 1000 hours, in function
Damp heat II ("tropical")	IEC60068-2-3	+60°C/95%rH, Toper max, Vccmax, 1000 hours, in function
High Temp. Operating Life (Life span)	IEC60068-2-2	1000hrs @ 85°C Ta Toper max, Vccmax
Dry heat II	IEC60068-2-2	+125°C, 1000 hours, no function
Function test at Umin, Unom, Umax	ISO16750-4 IEC60068-2-1 IEC60068-2-2	Function test at Umin, Unom, Umax 1 hour / voltage level Test at -40°C, RT, +85°C
Damp heat cyclic	IEC60068-2-30 Db Variation 1	+25°C...+55°C; >90% rH 6 cycles of 24 hours
Vibration in function	IEC60068-2-6	5-500 Hz; 5g; 2.5 hrs/axis at -40°C 2.5 hrs/axis at +85°C 3 hrs/axis at RT Total: 24 hours, function supervision
Mechanical Shock	IEC60068-2-27 Ea	30g/11ms (half sine), 3 Shocks/axis, no function
Robustness of terminations of Surface Mounted Devices	IEC60068-2-21 Ue1	1mm/s +/- 0.5mm/s D>2mm 1 Bending cycle Duration on Dmax: 20s +/- 1s
ESD (HBM)	JESD22-A114 AEC-Q100-002	Voltage level: 2000V
ESD (MM)	JESD22-A115 AEC-Q100-003	Voltage level: 200V

Table 14: u-blox qualification requirements

5.2 Approvals



Products marked with this lead-free symbol on the product label comply with the "Directive 2002/95/EC of the European Parliament and the Council on the Restriction of Use of certain Hazardous Substances in Electrical and Electronic Equipment" (RoHS).

All u-blox 6 GPS modules are RoHS compliant.

6 Product handling & soldering

6.1 Packaging

LEA-6 modules are delivered as hermetically sealed, reeled tapes in order to enable efficient production, production lot set-up and tear-down. For more information about packaging, see the u-blox Package Information Guide [3].



Figure 4: Reeled u-blox modules

6.1.1 Reels

LEA-6 GPS modules are deliverable in quantities of 250pcs on a reel. LEA-6 modules are delivered using reel Type B as described in the u-blox Package Information Guide [3].

Parameter	Specification
Reel Type	B
Delivery Quantity	250

Table 15: Reel information for LEA-6 modules

6.1.2 Tapes

Figure 5 shows the position and orientation of LEA-6 modules as they are delivered on tape. The dimensions of the tapes are specified in Figure 6.

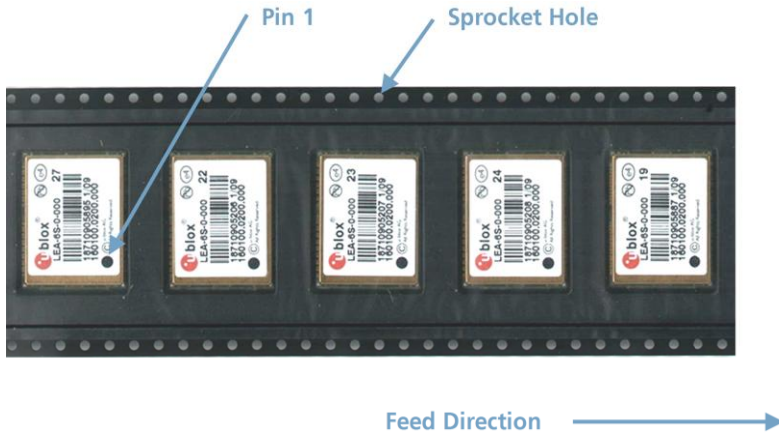
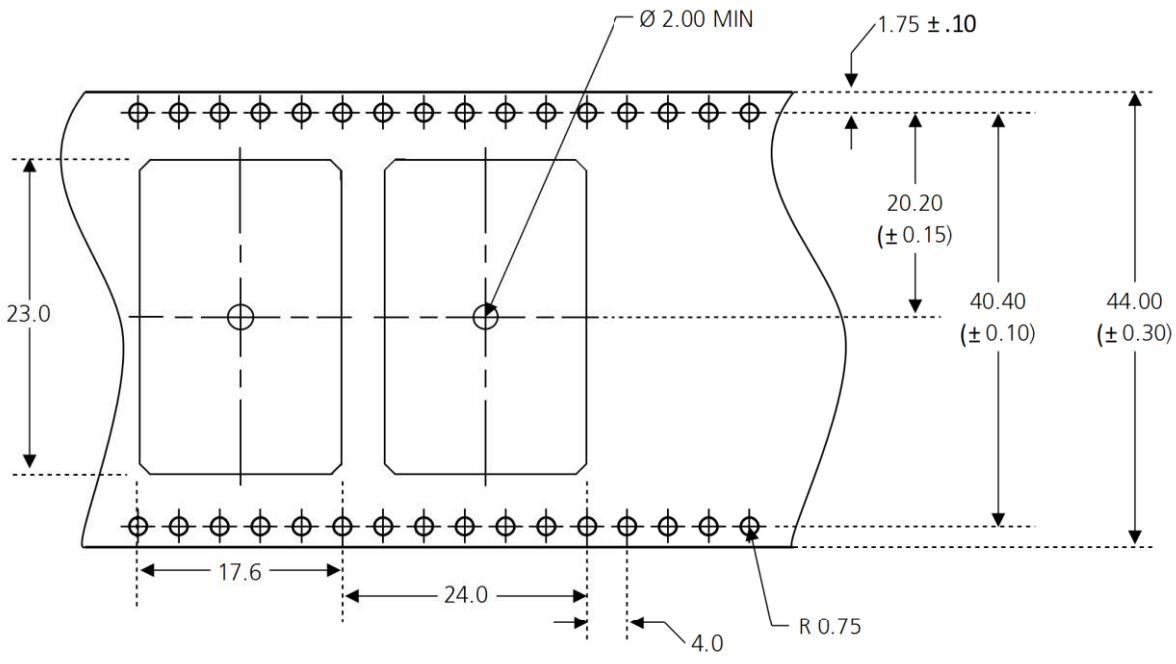

Figure 5: Orientation for LEA-6 modules on tape



Thickness of Module on Tape = 3.4(±0.1)mm

Figure 6: LEA tape dimensions (mm)

6.2 Moisture Sensitivity Levels



LEA-6 modules are Moisture Sensitive Devices (MSD) in accordance to the IPC/JEDEC specification.

LEA-6 modules are rated at MSL level 4. For more information regarding moisture sensitivity levels, labeling, storage and drying see the u-blox Package Information Guide [3].



For MSL standard see IPC/JEDEC J-STD-020, which can be downloaded from www.jedec.org.

6.3 Reflow soldering

Reflow profiles are to be selected according to u-blox recommendations (see LEA-6/NEO-6/MAX-6 Hardware Integration Manual [1]).

6.4 ESD handling precautions



LEA-6 modules contain highly sensitive electronic circuitry and are Electrostatic Sensitive Devices (ESD). Observe precautions for handling! Failure to observe these precautions can result in severe damage to the GPS receiver!



GPS receivers are Electrostatic Sensitive Devices (ESD) and require special precautions when handling. Particular care must be exercised when handling patch antennas, due to the risk of electrostatic charges. In addition to standard ESD safety practices, the following measures should be taken into account whenever handling the receiver:

- Unless there is a galvanic coupling between the local GND (i.e. the work table) and the PCB GND, then the first point of contact when handling the PCB must always be between the local GND and PCB GND.
- Before mounting an antenna patch, connect ground of the device
- When handling the RF pin, do not come into contact with any charged capacitors and be careful when contacting materials that can develop charges (e.g. patch antenna ~10pF, coax cable ~50-80pF/m, soldering iron, ...)
- To prevent electrostatic discharge through the RF input, do not touch any exposed antenna area. If there is any risk that such exposed antenna area is touched in non ESD protected work area, implement proper ESD protection measures in the design.
- When soldering RF connectors and patch antennas to the receiver's RF pin, make sure to use an ESD safe soldering iron (tip).



7 Default settings

Interface	Settings
Serial Port 1 Output	9600 Baud, 8 bits, no parity bit, 1 stop bit. Configured to transmit both NMEA and UBX protocols, but only following NMEA and no UBX messages have been activated at start-up: GGA, GLL, GSA, GSV, RMC, VTG, TXT (in addition to the 6 standard NMEA messages the LEA-6T includes ZDA).
USB Output	Configured to transmit both NMEA and UBX protocols, but only following NMEA and no UBX messages have been activated at start-up: GGA, GLL, GSA, GSV, RMC, VTG, TXT USB Power Mode: Bus-Powered. (in addition to the 6 standard NMEA messages the LEA-6T includes ZDA).
Serial Port 1 Input	9600 Baud, 8 bits, no parity bit, 1 stop bit Automatically accepts following protocols without need of explicit configuration: UBX, NMEA The GPS receiver supports interleaved UBX and NMEA messages.
USB Input	Automatically accepts following protocols without need of explicit configuration: UBX, NMEA The GPS receiver supports interleaved UBX and NMEA messages. USB Power Mode: Bus-Powered.
TIMEPULSE (1Hz Nav)	1 pulse per second, synchronized at rising edge, pulse length 100ms.
Power Mode	Maximum Performance mode, except LEA-6R which is in ECO mode.
AssistNow Autonomous	Disabled.

Table 16: Available Protocols.

Refer to the LEA-6/NEO-6/MAX-6 Hardware Integration Manual [1] for information about further settings.

8 Labeling and ordering information

8.1 Product labeling

u-blox 6 GPS module labels include important product information. The location of the product type number is shown in Figure 7.

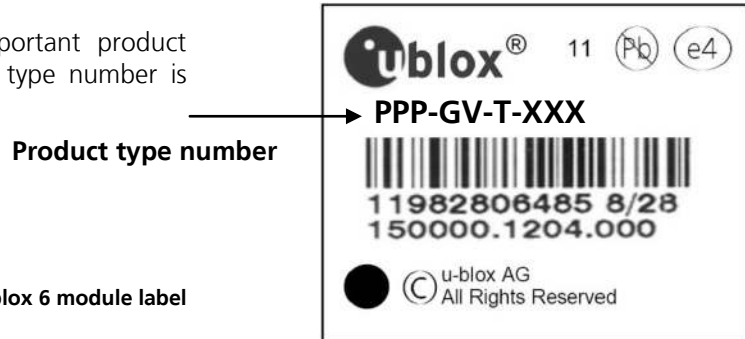

Figure 7: Location of product type number on u-blox 6 module label

8.2 Explanation of codes

Three different product code formats are used. The **Product Name** is used in documentation such as this data sheet and identifies all u-blox 6 products, independent of packaging and quality grade. The **Ordering Code** includes options and quality, while the **Type Number** includes the hardware and firmware versions. Table 17 below details these three different formats:

Format	Structure
Product Name	PPP-GV
Ordering Code	PPP-GV-T
Type Number	PPP-GV-T-XXX

Table 17: Product Code Formats

The parts of the product code are explained in Table 18.

Code	Meaning	Example
PPP	Product Family	LEA
G	Product Generation	6 = u-blox 6
V	Variant	T = Timing, R = DR, etc.
T	Option / Quality Grade	Describes standardized functional element or quality grade such as different RF connector, FLASH size, automotive grade etc.
XXX	Product Detail	Describes product details or options such as hard- and software revision, cable length, etc.

Table 18: part identification code

8.3 Ordering information

Ordering No.	Product
LEA-6A-0	u-blox 6 GPS Module, 17x22mm, 250 pcs/reel
LEA-6H-0	u-blox 6 GPS Module, TCXO, Flash, 17 x 22mm, 250 pcs/reel
LEA-6S-0	u-blox 6 GPS Module, TCXO, 17x22mm, 250 pcs/reel
LEA-6R-0	u-blox 6 GPS Module, Dead Reckoning, Flash, 17 x 22mm, 250 pcs/reel
LEA-6T-0	u-blox 6 GPS Module, Precision Timing, TCXO, 17 x 22mm, 250 pcs/reel
LEA-6T-1	u-blox 6 GPS module, Precision Timing, TCXO, Flash, 17x22mm 250pcs/reel
LEA-6T-2	u-blox 6 GPS module, Precision Timing, TCXO, Flash, 17x22mm 250pcs/reel

Table 19: Product Ordering Codes



Product changes affecting form, fit or function are documented by u-blox. For a list of Product Change Notifications (PCNs) see our website at: <http://www.u-blox.com/en/notifications.html>.

Related documents

- [1] LEA-6/NEO-6/MAX-6 Hardware Integration Manual, Docu. GPS.G6-HW-09007
- [2] u-blox 6 Receiver Description including Protocol Specification, Docu. No GPS.G6-SW-10018
- [3] u-blox Package Information Guide, Docu. No GPS-X-11004
- [4] GPS Compendium, Docu. No GPS-X-02007
- [5] GLONASS & GPS HW Designs Application Note, Docu. No GPS.G6-CS-10005



For regular updates to u-blox documentation and to receive product change notifications please register on our homepage.

Revision history

Revision	Date	Name	Status / Comments
	08/31/2009	tgri	Initial Release
1	09/21/2009	tgri	update of section 1.3 GPS performance, section 1.4 block diagram, section 3.2 peak supply current
A	5/02/2010	tgri	Change of status to Advance Information. Update of section 1.9.2, removed reference to Vddio – added USB driver certification. Update of section 3.2 table 11: average supply current & TTFF, section 5.1: addition of table 12.
B	4/23/2010	tgri	Inclusion of LEA-6R.
C	6/24/2010	dhur	Change of status to Preliminary. Update of section 1.3, 1.9.4, 1.12.2, 3.1, 3.2 and chapter 2 and 4. General clean-up and consistency check.
D	12/20/2010	dhur	Added information on LEA-6H with FW7.01 in section 1.3, 1.9 and 3.3. Updated Chapter 1.11.
E	06/06/2011	dhur	Added information on LEA-6T-1 in Table 1, chapters 1.3, 1.14 and 8.3.
E1	20/09/2011	cbib	Changed Status. Revised table section 1.2, updated section 1.3 GPS performance for FW 7.03, added section 1.8 GLONASS, updated P_{rfin} in section 3.1, updated chapter 6.
E2	25/04/2013	smos	Added PCN reference to product LEA-6R-0-002 on page 2. Revised contact page. Last revision with document number GPS.G6-HW-09004.
R10	27/11/2014	amil	Added LEA-6T-2
R11	07/09/2015	amil	Production status. Updated contacts.
R12	20/06/2016	amil	Modified Figure 3 dimension K
R13	17/02/2017	amil	Added FW6.04 (LEA-6T-2)

Contact

For complete contact information visit us at www.u-blox.com

u-blox Offices

North, Central and South America

u-blox America, Inc.

Phone: +1 703 483 3180
E-mail: info_us@u-blox.com

Regional Office West Coast:

Phone: +1 408 573 3640
E-mail: info_us@u-blox.com

Technical Support:

Phone: +1 703 483 3185
E-mail: support_us@u-blox.com

Headquarters Europe, Middle East, Africa

u-blox AG

Phone: +41 44 722 74 44
E-mail: info@u-blox.com
Support: support@u-blox.com

Asia, Australia, Pacific

u-blox Singapore Pte. Ltd.

Phone: +65 6734 3811
E-mail: info_ap@u-blox.com
Support: support_ap@u-blox.com

Regional Office Australia:

Phone: +61 2 8448 2016
E-mail: info_anz@u-blox.com
Support: support_ap@u-blox.com

Regional Office China (Beijing):

Phone: +86 10 68 133 545
E-mail: info_cn@u-blox.com
Support: support_cn@u-blox.com

Regional Office China (Chongqing):

Phone: +86 23 6815 1588
E-mail: info_cn@u-blox.com
Support: support_cn@u-blox.com

Regional Office China (Shanghai):

Phone: +86 21 6090 4832
E-mail: info_cn@u-blox.com
Support: support_cn@u-blox.com

Regional Office China (Shenzhen):

Phone: +86 755 8627 1083
E-mail: info_cn@u-blox.com
Support: support_cn@u-blox.com

Regional Office India:

Phone: +91 80 4050 9200
E-mail: info_in@u-blox.com
Support: support_in@u-blox.com

Regional Office Japan (Osaka):

Phone: +81 6 6941 3660
E-mail: info_jp@u-blox.com
Support: support_jp@u-blox.com

Regional Office Japan (Tokyo):

Phone: +81 3 5775 3850
E-mail: info_jp@u-blox.com
Support: support_jp@u-blox.com

Regional Office Korea:

Phone: +82 2 542 0861
E-mail: info_kr@u-blox.com
Support: support_kr@u-blox.com

Regional Office Taiwan:

Phone: +886 2 2657 1090
E-mail: info_tw@u-blox.com
Support: support_tw@u-blox.com