

Verpackt in Gurtverpackung - Tape on Reel Packaging
 Verpackungseinheit: 420 Stück - Packaging unit: 420 pcs

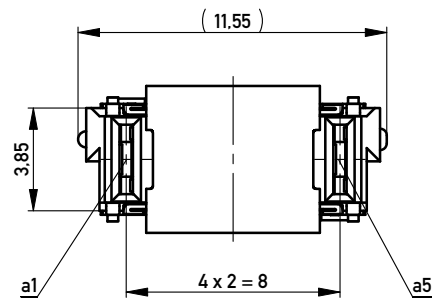

Abspulrichtung - Reel off Direction →

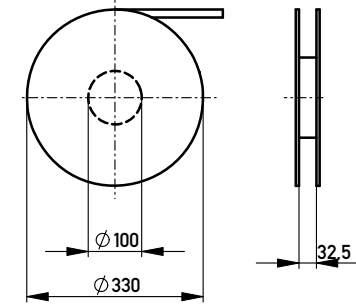
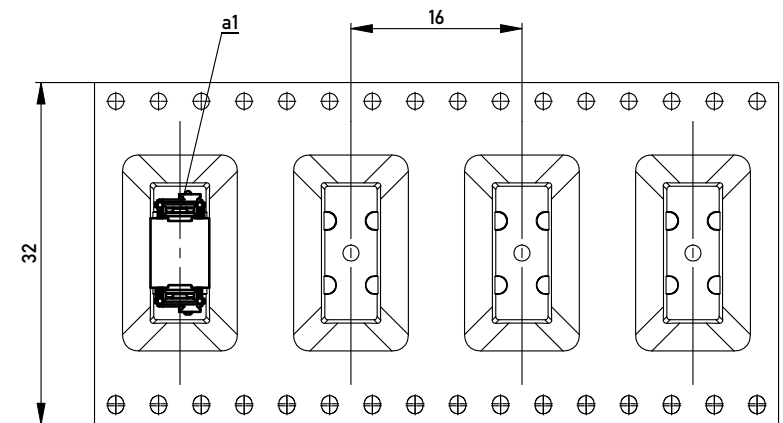

Leiterplatten-Layout Vorschlag / PCB-layout proposal

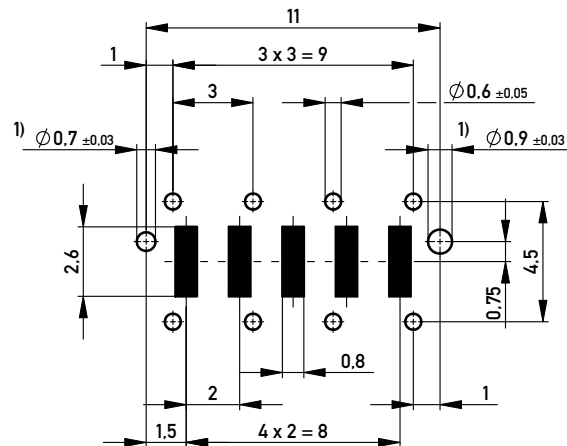



1) Durchmesser des Bohrers / Drill tool

Anforderungsstufe 1
 Performance Level 1

Kontaktbereich vergoldet
 Mating Area gold plating

Anschlussbereich verzinkt 4-6µm
 Terminal Area 4-6µm tin plating

Koplanarität der Anschlüsse ≤ 0.1mm
 Coplanarity Area of Termination ≤ 0.1mm

Information: All rights reserved. Only for Information. To ensure that this is the latest version of this drawing, please contact one of the ERNI companies before using.	Tolerances  All Dimensions in mm	Scale 5:1	
		Designation Federleiste THR, Powerm. 4mm Female Con. THR, Powerm. 4mm	
f Index	12.10.2010 Date	 www.ERNI.com	214912 Class MSPEED
			I A3

Copyright by ERNI GmbH
 Proprietary notice pursuant to ISO 16106 to be observed.