

OGA DIAG 34.16 [867.67]
 VA DIAG 31.81 [807.87]
 PA DIAG 30.00 [762.00]

TOP LEVEL NUMBER	US NUMBER	TYPE	DIM "A" (TOTAL GLASS TO CONNECTOR)	A/G FINISH	PROD SPEC
17-8951-205	98-0003-2678-9	FFC	8.00" [203.20]	AG500	23655
17-8951-227	98-0003-2681-3	SER	8.00" [203.20]	AG500	23655
17-8951-206	98-0003-2679-7	NOV	SEE DWG	AG500	23655
17-8951-226	98-0003-3029-4	USB R	8.00" [203.20]	AG500	23655
N/A	98-1100-0126-4	USB R FW9	8.00" [203.20]	AG500	23655
N/A	98-1100-0110-8	FFC	8.00" [203.20]	WC100	34523
N/A	98-1100-0111-6	USB R FW9	8.00" [203.20]	WC100	34523

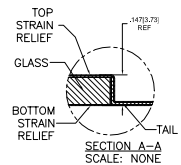
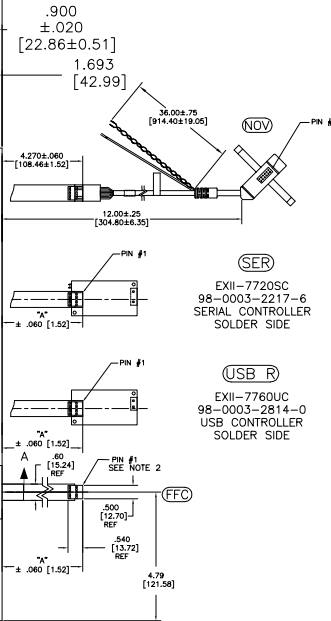
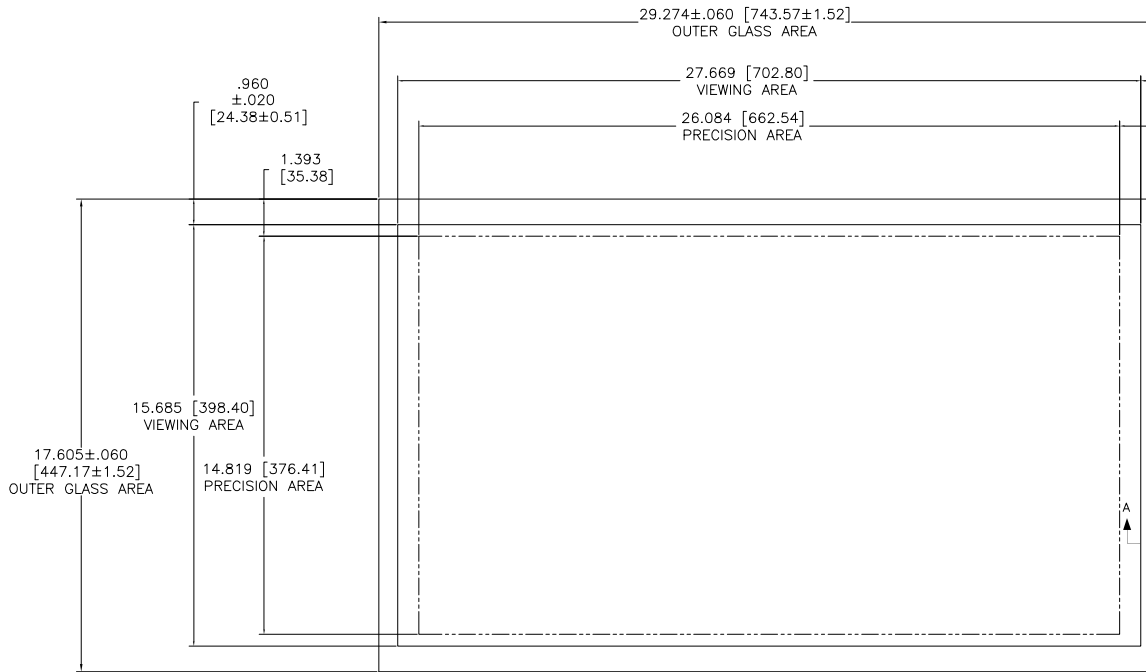

- NOTES:
1. WEIGHT OF GLASS IN GRAMS: 2533±10%
 2. NICOMATIC HOUSING P/N: OLOS
 NICOMATIC RECEPTACLES (PINS) MATTE TIN PLATED P/N: 14106-12
 HOUSING ORIENTED WITH LATCH DOWN

PINOUT	
1	UL
2	UR
3	SHLD
4	LR
5	LL

UNITS INCHES [MM]

3M 3M TOUCH SYSTEMS
 METHUEN, MA
 USA

© COPYRIGHT THIS DOCUMENT IS COPYRIGHTED PROPERTY OF THE 3M COMPANY AND MAY NOT BE REPRODUCED WITHOUT 3M WRITTEN PERMISSION OR USED OR DISCLOSED FOR OTHER THAN 3M AUTHORIZED PURPOSES.

THIRD ANGLE PROJECTION

DO NOT SCALE DRAWING

SCALE 1 = 1

DRAWN K.CROWLEY 01/06

REV	CHANGE NOTICE	DATE	DRW
L	REVISED PER CO 036265	4/13	SB
K	REVISED PER CO 036120	2/13	SB

TITLE

MARKETING DRAWING
 SCT32NN 31.81" W

CAD FORMAT AUTOCAD SHEET 1 OF 1

SIZE E DOCUMENT NO. TSD-28436 REV L