



## Dual Directional 20 dB SMA Coupler From 2 GHz to 8 GHz Rated to 50 Watts

### Couplers Technical Data Sheet

PE2CP1113

#### Features

- 2 to 8 GHz
- 50 Watts CW Max Power
- 20 dB Coupling Value
- Dual Directional SMA Coupler
- Meets Standards for Humidity, Shock, Vibration, Altitude

#### Applications

- Communications Systems
- CDMA, GSM, LTE
- Amplifier Systems
- Amplifier Power Dividing
- Aviation/Aerospace
- Defense Applications
- Wireless Telecommunications

#### Description

The PE2CP1113 is an 20 dB RF coupler with 50 ohm SMA connectors operating from 2 to 8 GHz with a maximum input power of 50 Watts CW, and peak power handling of 2 kilowatt. The PE2CP1113 has a coupling factor of 1 dB, insertion loss of (excluding coupled power) and a maximum VSWR of 1.2:1. The coupler operates over a temperature range of -45° to 85° C and meets environmental standard for humidity, shock, vibration, and altitude. Couplers have many Applications and perform several functions within the RF/Microwave industry such as circuit feedback and signal sampling for measurement or monitoring.

#### Electrical Specifications

Description	Minimum	Typical	Maximum	Units
Frequency Range	2		8	GHz
Impedance		50		Ohms
Coupling	19	20	21	dB
Frequency Sensitivity		±0.5	±0.7	dB
Insertion Loss			0.5	dB
Directivity	20	22		dB
Main Line VSWR		1.18:1	1.2:1	
Input Power (CW)			50	Watts
Input Power (Peak)			2	kWatts

#### Mechanical Specifications

<b>Size</b>	
Length	1.69 in [42.93 mm]
Width/Dia.	0.43 in [10.92 mm]
Height	0.94 in [23.88 mm]
<b>Finish</b>	
Housing Material and Plating	Gray Aluminum

Click the following link (or enter part number in "SEARCH" on website) to obtain additional part information including price, inventory and certifications: [Dual Directional 20 dB SMA Coupler From 2 GHz to 8 GHz Rated to 50 Watts PE2CP1113](#)



## Dual Directional 20 dB SMA Coupler From 2 GHz to 8 GHz Rated to 50 Watts

### Couplers Technical Data Sheet

PE2CP1113

#### Configuration

Input Connector	SMA Female
Output Connector	SMA Female
Coupled Connectors	SMA Female

#### Environmental Specifications

##### Temperature

Operating Range	-45 to +85 deg C
Storage Range	-55 to +125 deg C

Humidity

100% RH at 35°C, 95% RH at 40°C

Shock

20G for 11msec half sine wave, 3 axis both directions

Vibration

25g RMS (15 degrees 2KHz) endurance, 1 hour per axis

Altitude

30,000 ft. (Epoxy Sealed Controlled environment)

**Compliance Certifications** (see [product page](#) for current document)

#### Plotted and Other Data

Notes:

Dual Directional 20 dB SMA Coupler From 2 GHz to 8 GHz Rated to 50 Watts from Pasternack Enterprises has same day shipment for domestic and International orders. Our RF, microwave and millimeter wave products maintain a 99.4% availability and are part of the broadest selection in the industry.

Click the following link (or enter part number in "SEARCH" on website) to obtain additional part information including price, inventory and certifications: [Dual Directional 20 dB SMA Coupler From 2 GHz to 8 GHz Rated to 50 Watts PE2CP1113](#)

URL: <https://www.pasternack.com/dual-directional-20-db-sma-coupler-8-ghz-pe2cp1113-p.aspx>

The information contained in this document is accurate to the best of our knowledge and representative of the part described herein. It may be necessary to make modifications to the part and/or the documentation of the part, in order to implement improvements. Pasternack reserves the right to make such changes as required. Unless otherwise stated, all specifications are nominal. Pasternack does not make any representation or warranty regarding the suitability of the part described herein for any particular purpose, and Pasternack does not assume any liability arising out of the use of any part or documentation.

# PE2CP1113 CAD Drawing

Dual Directional 20 dB SMA Coupler From 2 GHz to 8 GHz Rated to 50 Watts

REVISIONS			
REV.	DESCRIPTION	DATE	APPROVED
A	INITIAL RELEASE	5/18/2020	S. PONG

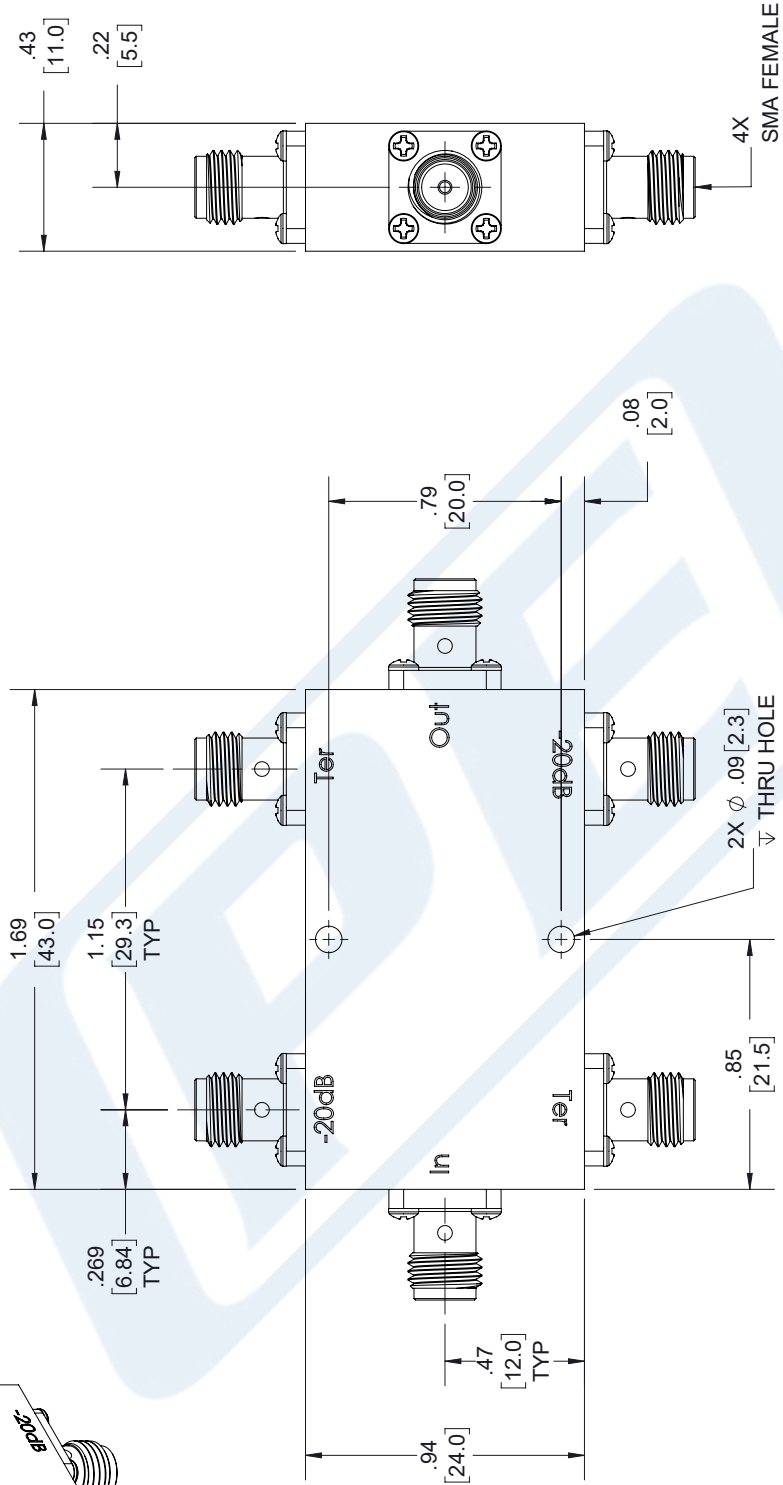
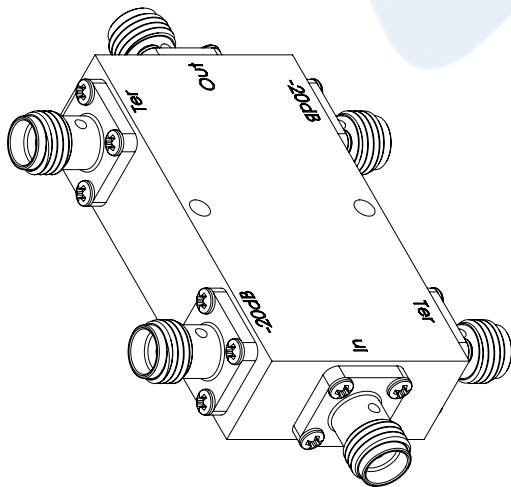

UNLESS OTHERWISE SPECIFIED  
LEADING DIMENSIONS ARE INCHES  
DIMENSIONS IN [ ] ARE MILLIMETERS

TOLERANCES:  
 .X = ±.2 [5.08] FRACTIONS  
 .XX = ±.02 [.51] ±.1/32  
 .XXX = ±.005 [.13] ANGLES ± 1°  
 CABLE LENGTH (L) TOLERANCES:  
 L ≤ 12 [305] = +1 [25] / -0  
 12 [305] < L ≤ 60 [1524] = +2 [51] / -0  
 60 [1524] < L ≤ 120 [3048] = +4 [102] / -0  
 120 [3048] < L ≤ 300 [7620] = +6 [152] / -0  
 300 [7620] < L = +5%L / -0

ALL DIMENSIONS SHOWN  
ARE FOR REFERENCE ONLY.

**PE PASTERNAK**  
an INFINITI brand

Pasternack Enterprises, Inc.  
P.O. Box 16759, Irvine, CA 92623.  
Phone: 1.949.261.1920 | 1.866.727.8376  
Fax: 1.949.261.7451  
Website: www.pasternack.com  
E-mail: sales@pasternack.com

THIRD-ANGLE PROJECTION

THE INFORMATION AND DESIGN IN THIS DOCUMENT IS THE PROPERTY OF PASTERNAK CORPORATION. ALL RIGHTS RESERVED.

SHEET 1 OF 1  
SCALE N/A

REV A  
ITEM NO. PE2CP1113  
DRAWN BY K.Dang  
CAGE CODE A 53919

LABEL:  
PASTERNAK  
PE2CP1113  
D/C: YYYY

THESE COMMODITIES, TECHNOLOGY OR SOFTWARE WERE EXPORTED FROM THE UNITED STATES IN ACCORDANCE WITH THE EXPORT ADMINISTRATION REGULATIONS. DIVERSION CONTRARY TO U.S. LAW PROHIBITED.