



**FocusLCDs.com**  
LCDs MADE SIMPLE®

Ph. 480-503-4295 | [NOPP@FocusLCD.com](mailto:NOPP@FocusLCD.com)

TFT | CHARACTER | UWVD | FSC | SEGMENT | CUSTOM | REPLACEMENT

## TFT Display Module

Part Number

E70RG38048LW2M450-N

### Overview:

- 7.0-inch TFT (165x149.1mm)
- 16/18/24-bit RGB Interface
- 800(RGB)x840 pixels
- 3.3V
- White LED back-light
- Transmissive/ Normally White
- No Touch Panel
- 450 NITS
- Controller: EK9713/EK7330
- RoHS Compliant

## Description

This is a color active matrix TFT (Thin Film Transistor) LCD (Liquid Crystal Display) that uses amorphous silicon TFT as a switching device. This model is composed of a transmissive type TFT-LCD Panel, driver circuit and backlight unit. The resolution of the 7.0" TFT-LCD contains 800x480 pixels and can display up to 65K/262K/16.7M colors.

## Features

Low Input Voltage: 3.3V (TYP)

Display Colors of TFT LCD: 65K/262K/16.7M colors

Interface: 16/18/24-bit RGB

General Information Items	Specification	Unit	Note
	Main Panel		
TFT Display area (AA)	154.08(H) * 85.92(V) (7.0 inch)	mm	-
Driver element	TFT active matrix	-	-
Display colors	65K/262K/16.7M	colors	-
Number of pixels	800(RGB)*480	dots	-
TFT Pixel arrangement	RGB vertical stripe	-	-
Pixel pitch	0.0642 (H) x 0.1790 (V)	mm	-
Viewing angle	12:00	o'clock	-
TFT Controller IC	EK9713/EK7330	-	-
Display mode	Transmissive/ Normally White	-	-
Operating temperature	-20~+70	°C	-
Storage temperature	-30~+80	°C	-

## Mechanical Information

Item		Min	Typ.	Max	Unit	Note
Module size	Horizontal(H)		165		mm	-
	Vertical(V)		100		mm	-
	Depth(D)		5.8		mm	-
Weight			TBD		g	-

## 1. Block Diagram

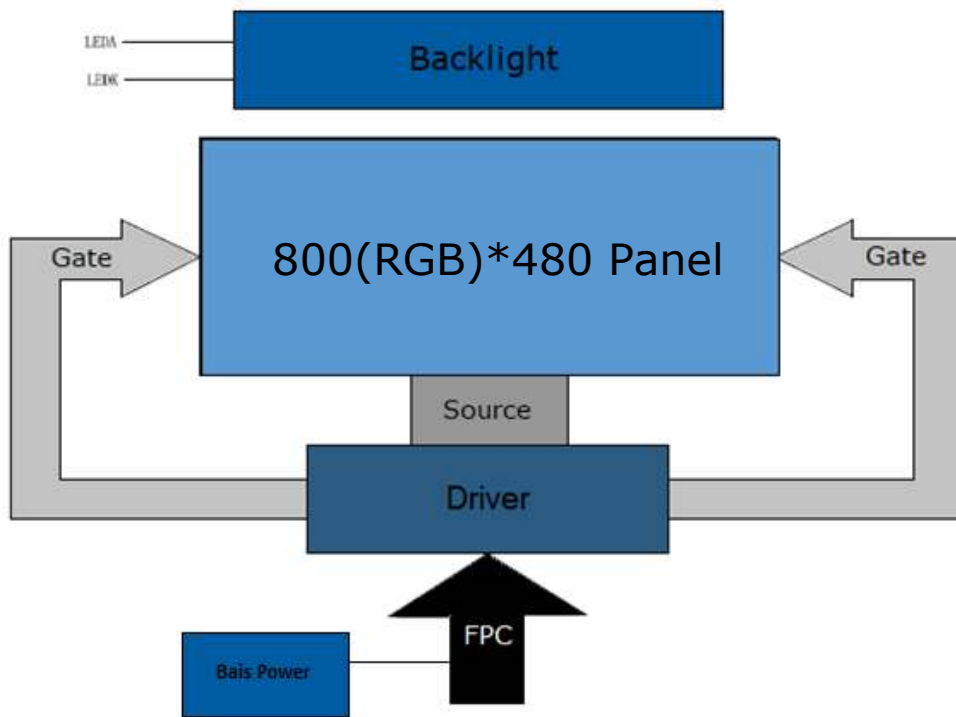

## 2. Outline dimensions

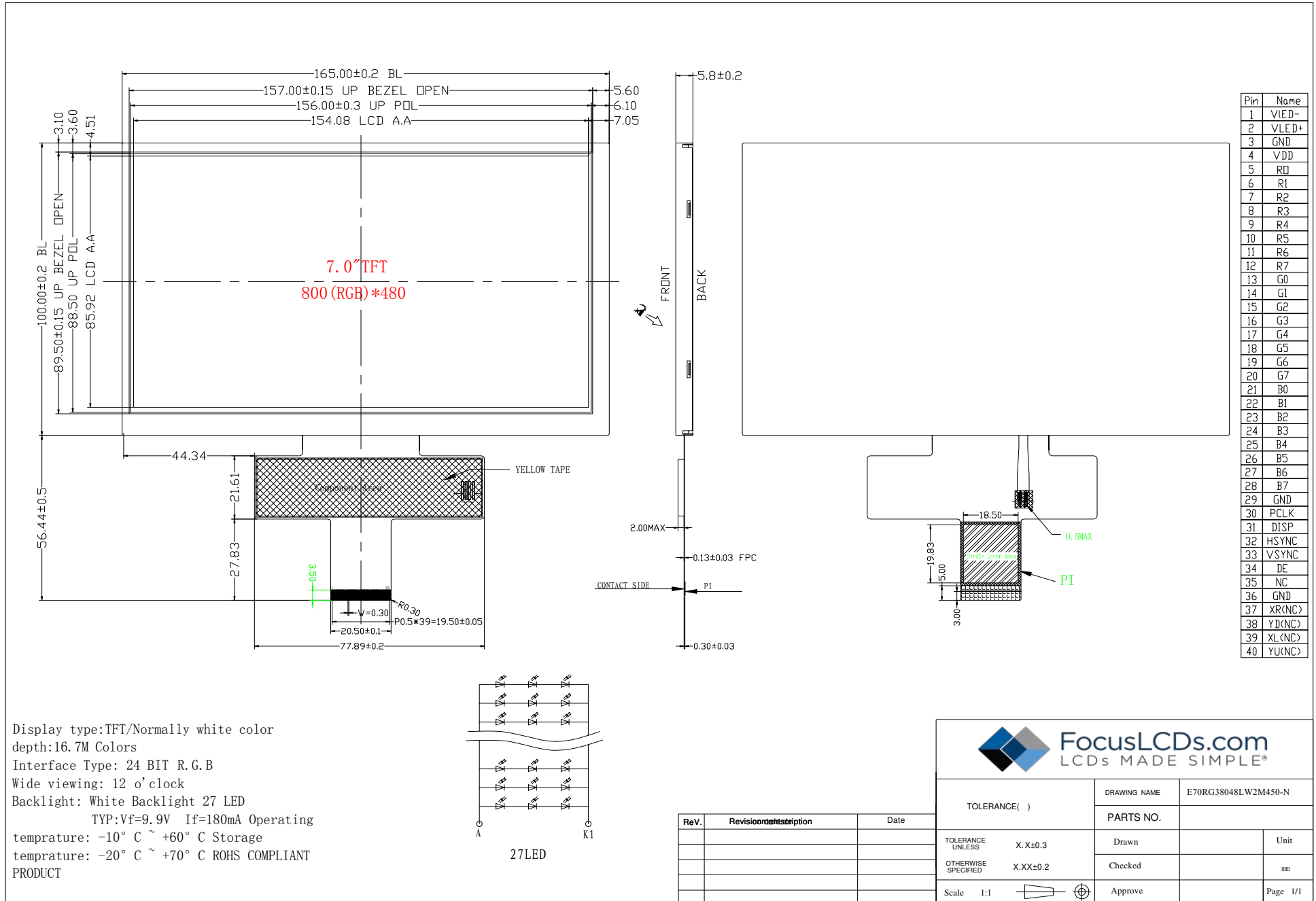

### 3. Input Terminal Pin Assignment

#### 3.1 TFT

NO.	Symbol	Description	I/O
1	VLED-	Cathode pin of backlight	P
2	VLED+	Anode pin of backlight	P
3	GND	Ground	P
4	VDD	Supply voltage (3.3V)	P
5	R0	Red data input	I/O
6	R1	Red data input	I/O
7	R2	Red data input	I/O
8	R3	Red data input	I/O
9	R4	Red data input	I/O
10	R5	Red data input	I/O
11	R6	Red data input	I/O
12	R7	Red data input	I/O
13	G0	Green data input	I/O
14	G1	Green data input	I/O
15	G2	Green data input	I/O
16	G3	Green data input	I/O
17	G4	Green data input	I/O
18	G5	Green data input	I/O
19	G6	Green data input	I/O
20	G7	Green data input	I/O
21	B0	Blue data input	I/O
22	B1	Blue data input	I/O
23	B2	Blue data input	I/O
24	B3	Blue data input	I/O
25	B4	Blue data input	I/O
26	B5	Blue data input	I/O
27	B6	Blue data input	I/O
28	B7	Blue data input	I/O
29	GND	Ground	P
30	PCLK	Dot clock signal for RGB interface operation. Fix to VCI or GND when not used.	I
31	DISP	Standby setting for testing. Connect to VDDIO in normal operation mode. If connected to GND the IC is in standby mode.	I
32	HSYNC	Line synchronizing signal for RGB interface operation. Fix to VCI or GND when not used.	I
33	VSYNC	Frame synchronizing signal for RGB interface operation. Fix to VCI or GND when not used.	I
34	DE	Data enable signal for RGB interface operation. Fix to VCI or GND when not used.	I
35	NC		
36	GND	Ground	P
37	XR	Touch panel right glass terminal	A/D
38	YD	Touch panel bottom film terminal	A/D
39	XL	Touch panel left glass terminal	A/D
40	YU	Touch panel top film terminal	A/D

## 4. LCD Optical Characteristics

### 4.1 Optical Specifications

Item	Symbol	Condition	Min	Typ.	Max	Unit	Note	
Contrast Ratio	CR	$\Theta = \phi = 0$ Normal viewing angle	400	500	--		(2)	
Transmittance	T(%)		--	5.11	--	--	(3)	
Response time	Rising		TR	--	10	20	msec	(4)
	Falling		TF	--	15	30		
Color Gamut	S (%)		--	--	--	--	%	(5)
Color Filter Chromaticity	White		$W_x$	0.26	0.31	0.36		(5)(6)
		$W_y$	0.28	0.33	0.38			
Viewing angle	Hor.	$\Theta_L$	$\phi=180^\circ$ (9 o'clock)	60	70	--	(1)(6)	
		$\Theta_R$	$\phi=0^\circ$ (3 o'clock)	60	70	--		
	Ver.	$\Theta_T$	$\phi=90^\circ$ (12 o'clock)	40	50	--		
		$\Theta_B$	$\phi=270^\circ$ (6 o'clock)	60	70	--		
Option View Direction	12:00						(1)	

### 4.2 Measuring Condition

VDD = 3.3V, IL = 20mA (Backlight current)

Ambient temperature:  $25 \pm 2^\circ\text{C}$

15min. warm-up time

**Optical Specification Reference Notes:**

(1) Definition of Viewing Angle: The viewing angle is the angle at which the contrast ratio is greater than 10. The viewing angles are determined for the horizontal or 3,9 o'clock direction and the vertical or 6,12 o'clock direction with respect to the optical axis which is normal to the LCD surface.

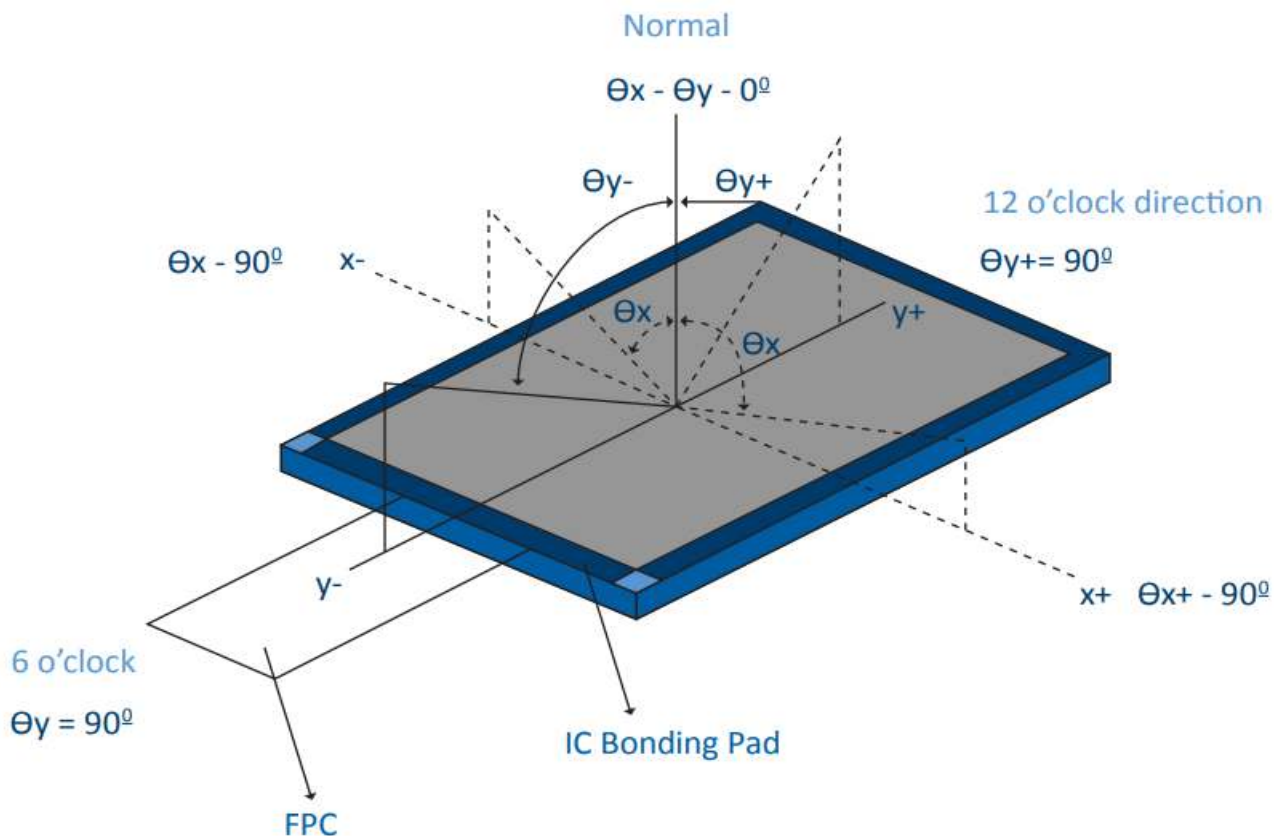
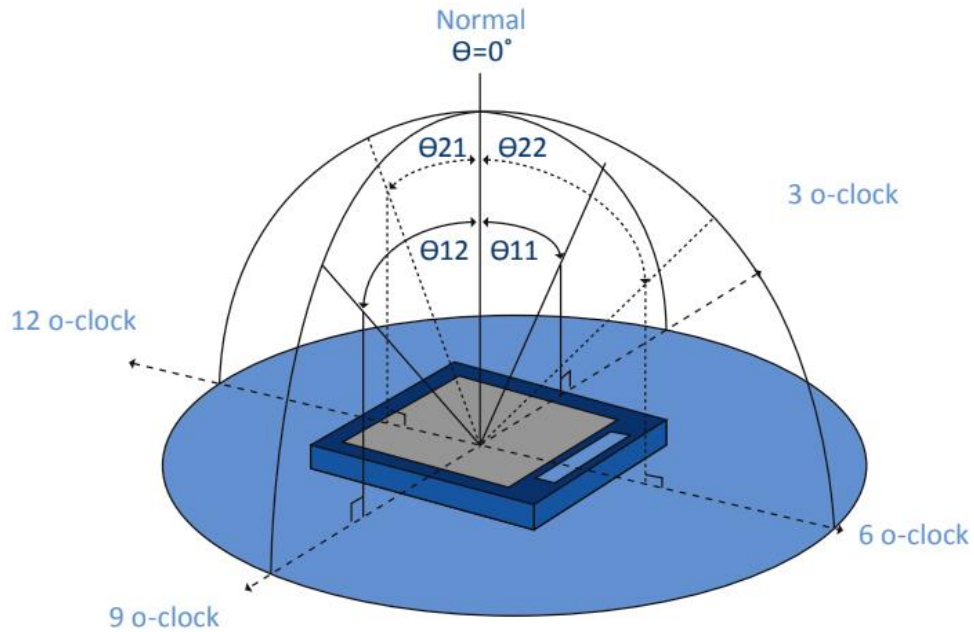

(2) Definition of Contrast Ratio (Cr): measured at the center point of panel. The contrast ratio (Cr) measured on a module, is the ratio between the luminance (Lw) in a full white area (R=G=B=1) and the luminance (Ld) in a dark area (R=G=B=0).

$$Cr = \frac{L_w}{L_d}$$

(3) Definition of transmittance (T%): The transmittance of the panel including the polarizers is measured with electrical driving.

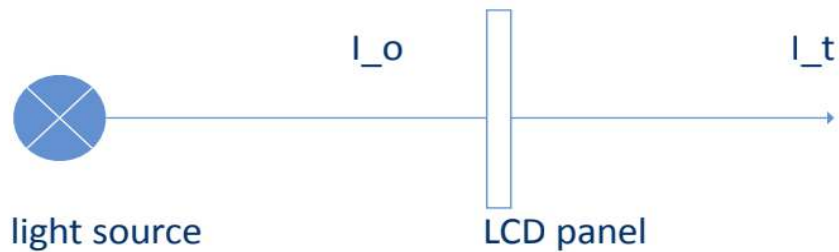

The transmittance is defined as:

$$Tr = \frac{I_t}{I_o} \times 100\%$$

I<sub>o</sub> = the brightness of the light source.

I<sub>t</sub> = the brightness after panel transmission

(4) Definition of Response Time (Tr, Tf): The rise time 'Tr' is defined as the time for luminance to change from 90% to 10% as a result of a change of the electrical condition. The fall time 'Tf' is defined as the time for luminance to change from 10% to 90% as a result of a change of the electrical condition.

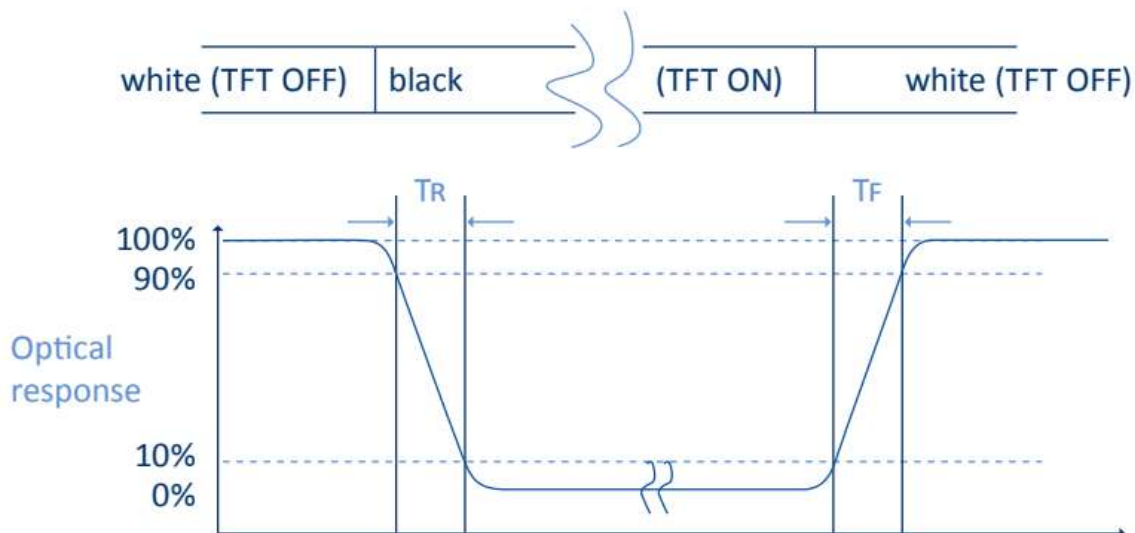



(5) Definition of Color Gamut: Measuring machine CFT-01. NTSC's Primaries: R(x,y,Y),G(x,y,Y), B(x,y,Y). FPM520 of Westar Display Technologies, INC., which utilized SR-3 for Chromaticity and BM-5A for other optical characteristics. The color chromaticity shall be calculated from the spectral data measured with all pixels first in red, green, blue and white. Measurements shall be made at the center of the panel.

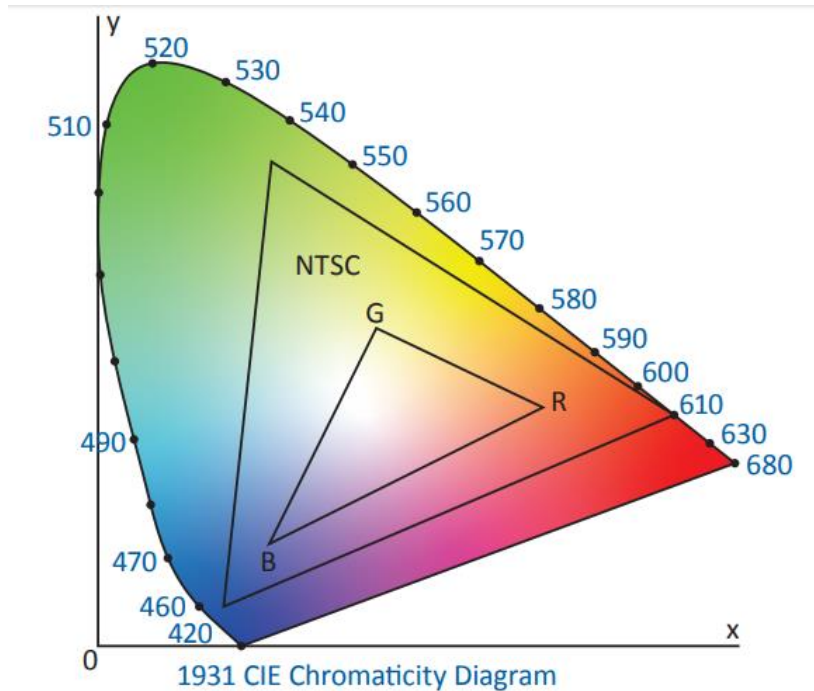
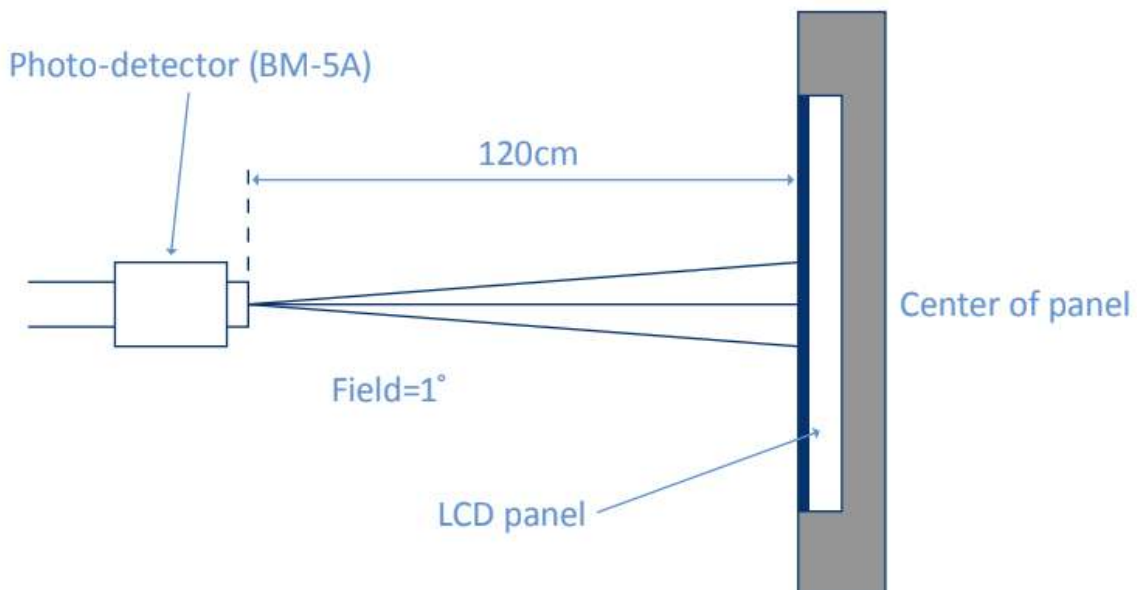

Fig. 1931 CIE chromacity diagram

$$\text{Color gamut: } S = \frac{\text{Area of RGB triangle}}{\text{Area of NTSC triangle}} \times 100\%$$

(6) Definition of Optical Measurement Setup:



(6) Optical Measurement Setup Continued:

The LCD module should be stabilized at a given temperature for 20 minutes to avoid abrupt temperature change during measuring. In order to stabilize the luminance, the measurement should be executed after lighting backlight for 20 minutes.

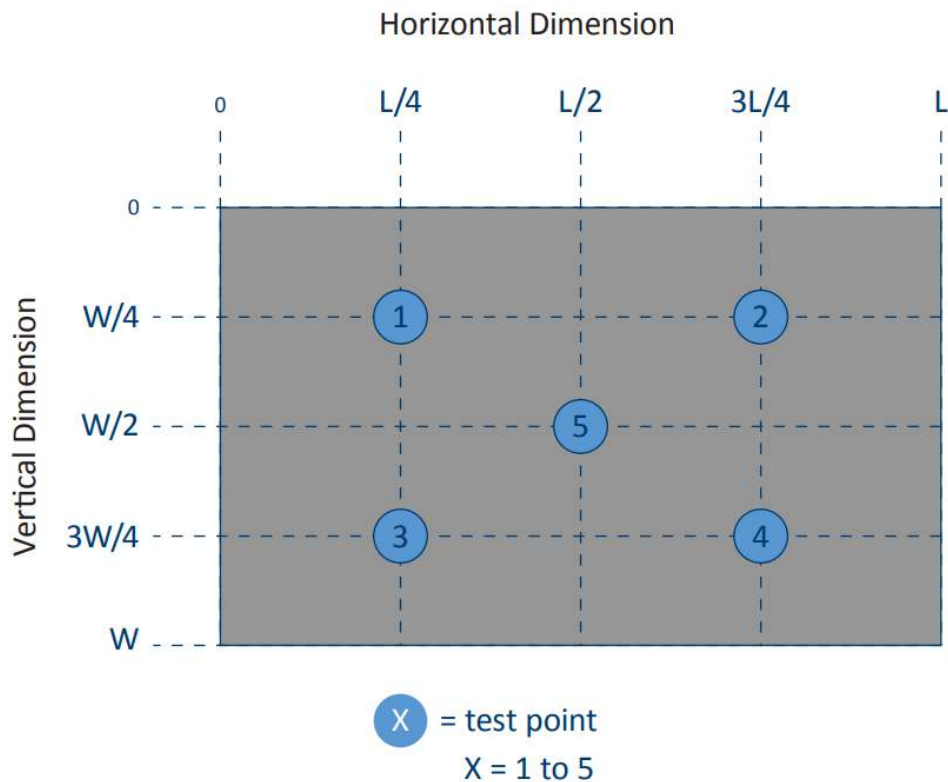
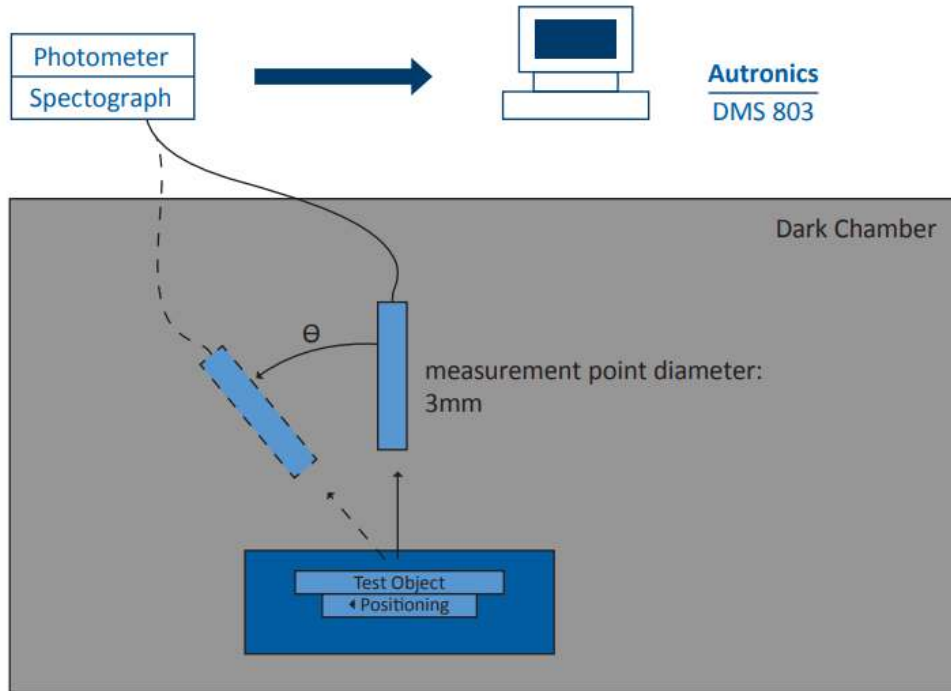

## 5. Electrical Characteristics

### 5.1 Absolute Maximum Rating

Characteristics	Symbol	Min	Max	Unit
Digital Supply Voltage	VDD	-0.5	5.0	V
Digital Interface Supply Voltage	VDDIO	-0.5	VDD+0.3	V
Operating Temperature	TOP	-20	+70	°C
Storage Temperature	TST	-30	+80	°C

NOTE: If the absolute maximum rating of even is one of the above parameters is exceeded even momentarily, the quality of the product may be degraded. Absolute maximum ratings, therefore, specify the values exceeding which the product may be physically damaged. Be sure to use the product within the range of the absolute maximum ratings.

### 5.2 DC Electrical Characteristics

Characteristics	Symbol	Min	Typ.	Max	Unit	Note
Digital Supply Voltage	VDD	3.0	3.3	3.6	V	
Digital Interface Supply Voltage	VDDIO	3.0	3.3	3.6	V	
Normal Mode Current Consumption	IDD	--	150	--	mA	
Level input voltage	VIH	0.7VDDIO	--	VDDIO	V	
	VIL	GND	--	0.3VDDIO	V	
Level output voltage	VOH	0.8 VDDIO	--	VDDIO	V	
	VOL	GND	--	0.2 VDDIO	V	

### 5.3 LED Backlight Characteristics

The backlight system is edge lighting type with 27 chips LED.

Item	Symbol	Min	Typ.	Max	Unit	Note
Forward Current	IF	135	180	--	mA	
Forward Voltage	VF	--	9.6	--	V	
LCM Luminance	LV	450	--	--	cd/m2	Note 3
LED lifetime	Hr	50000	--	--	hour	Note1 & 2
Uniformity	AVg	80	--	--	%	Note 3

Note 1: LED lifetime (Hr) can be defined as the time in which it continues to operate under the condition: Ta=25 ±3 °C, typical IL value indicated in the above table until the brightness becomes less than 50%.

Note 2: The “LED lifetime” is defined as the module brightness decrease to 50% original brightness at Ta=25°C and IL = 180mA. The LED lifetime could be decreased if operating IL is larger than 180mA. The constant current driving method is suggested.

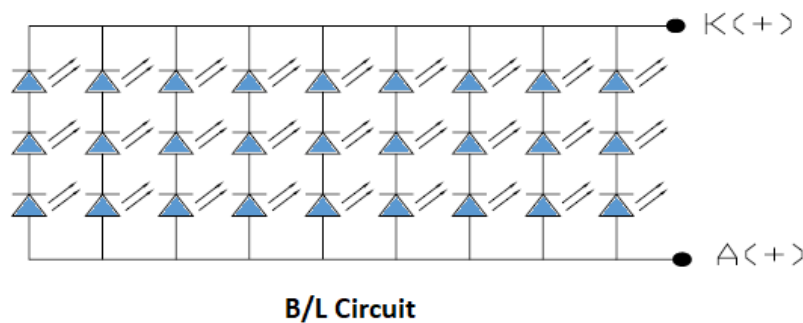

Note 3: Luminance Uniformity of these 9 points is defined as below:

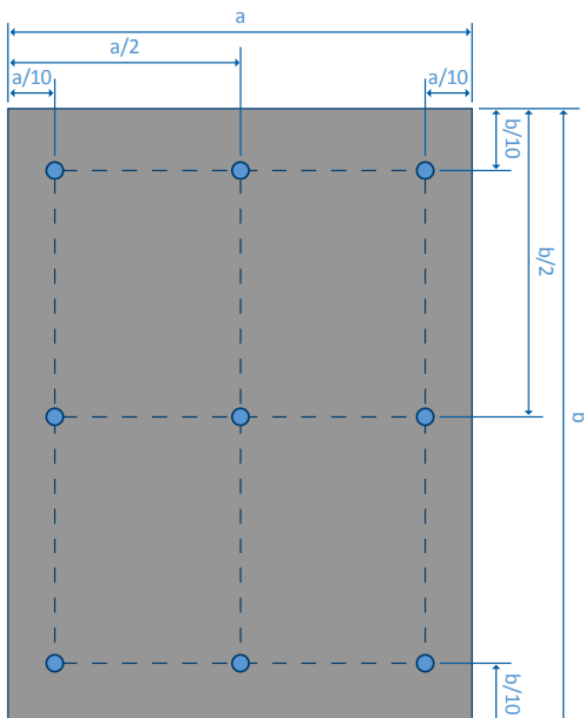

$$\text{Luminance} = \frac{\text{(Total Luminance of 9 points)}}{9}$$

$$\text{Uniformity} = \frac{\text{minimum luminance in 9 points(1-9)}}{\text{maximum luminance in 9 points(1-9)}}$$

## 6. Timing Characteristics

### 6.1 Vertical and Horizontal Input Timing

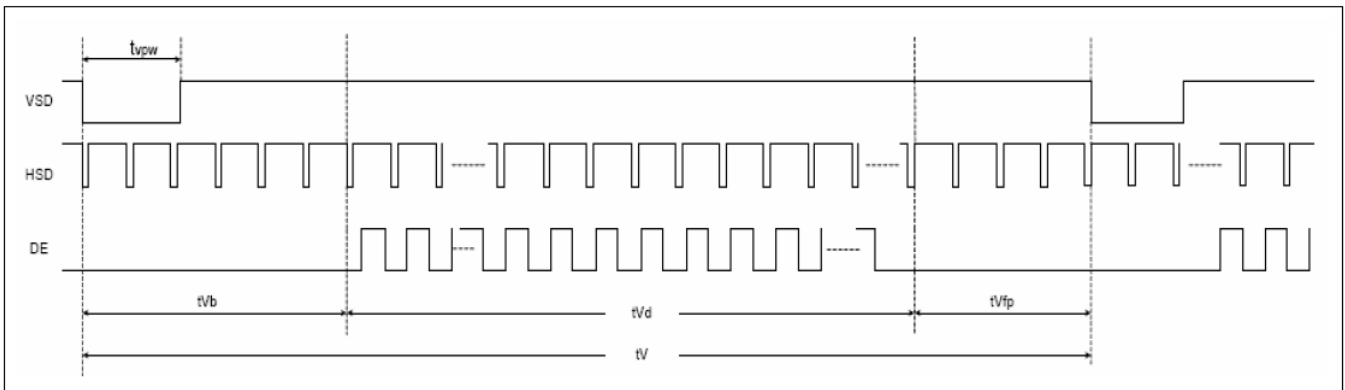

Figure 6.1: Vertical Input Display Timing Diagram

Parameter	Symbol	Min	Typ.	Max	Unit	Note
Vertical Display Area	tvd	480	480	480	H	
VSD Period Time	tv	510	525	650	H	
VSD Pulse Width	tvpw	1	--	20	H	
VSD Back Porch (Blanking)	tvb	23	23	23	H	
VSD Front Porch	tvfp	7	22	147	H	

Table 6.1: Vertical Input Display Timing Characteristics

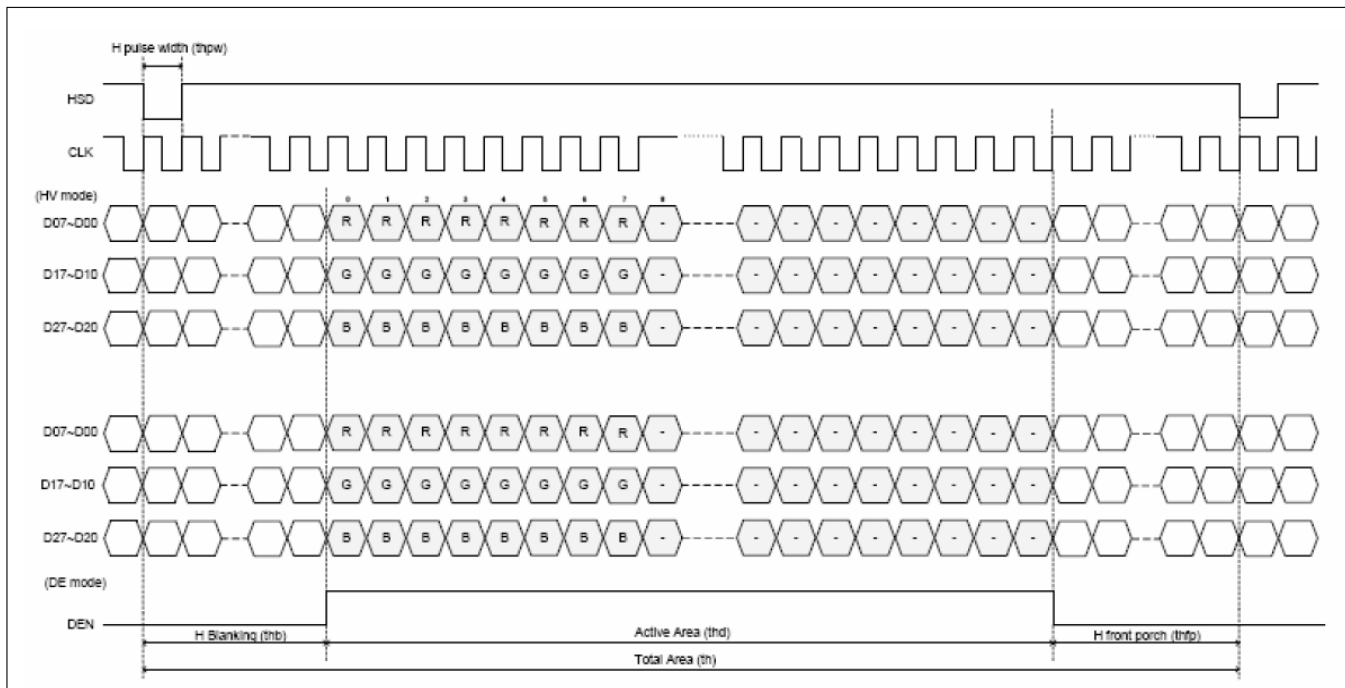

Figure 6.2: Horizontal Input Display Timing Diagram

Parameter	Symbol	Min	Typ.	Max	Unit	Note
Horizontal Display Area	thd	800	800	800	DCLK	
DCLK Frequency	fclk	--	33.3	50	MHz	
1 Horizontal Line	th	862	1056	1200	DCLK	
HSD Pulse Width	thpw	1	--	40	DCLK	
HSD Back Porch (Blanking)	thb	46	46	46	DCLK	
HSD Front Porch	thfp	16	210	354	DCLK	

Table 6.2: Horizontal Input Display Timing Characteristics

## 6.2 AC Characteristics

Parameter	Symbol	Condition	Min	Typ.	Max	Unit
VDD power on slew rate	TPOR	From 0V to 90% VDD	--	--	20	ms
RSTB pulse width	TRST	CLKIN=40MHz	1	--	--	ms
CLKIN cycle time	Tcph		20	--	--	ns
VSD setup time	Tcwh		40	50	60	%
VSD hold time	Tvst		8	--	--	ns
HSD setup time	Tvhd		8	--	--	ns
HSD hold time	That		8	--	--	ns
Data setup time	Thhd		8	--	--	ns
Data hold time	Tdsu	D0[7:0], D1[7:0], D2[7:0] to CLKIN	8	--	--	ns
DEN setup time	Tdhd	D0[7:0], D1[7:0], D2[7:0] to CLKIN	8	--	--	ns
DEN hold time	Tesu		8	--	--	ns
Output stable time	Tsst	10% to 90% target voltage. CL=120pF, R=10kΩ	--	--	6	us

Table 6.3: AC Characteristics (TA=-20 to 85C, VDD=3-3.6V, AVDD=6.5-13.5V, GND=AVSS=0V)

## 6.3 24-bit Parallel RGB Mode

Parameter	Symbol	Condition	Min	Typ.	Max	Unit
CLKIN Frequency	Fclk	VDD=3.0V-3.6V	-	33.3	50	MHz
CLKIN Cycle Time	Tclk		20	30	-	ns
CLKIN Pulse Duty	Tcwh	Tclk=Tcwh+cwl	40	50	60	%
	Tcwl		40	50	60	%
VSD to STV	Tstv	HV mode	-	24	-	H
DEN to STV	Tstv	DE mode	-	4	-	CLKIN
STV pulse width	Twstv		-	0.5	-	H
STV to CKV	Tckv		-	18	-	CLKIN
STV to OEV	Toev		-	2	-	CLKIN
CKV pulse width	Twckv		-	66	-	CLKIN
OEV pulse width	Twoev		-	50	-	CLKIN

Table 6.4: Parallel 24-bit RGB Mode Timing Characteristics

## 6.4 Timing Waveforms

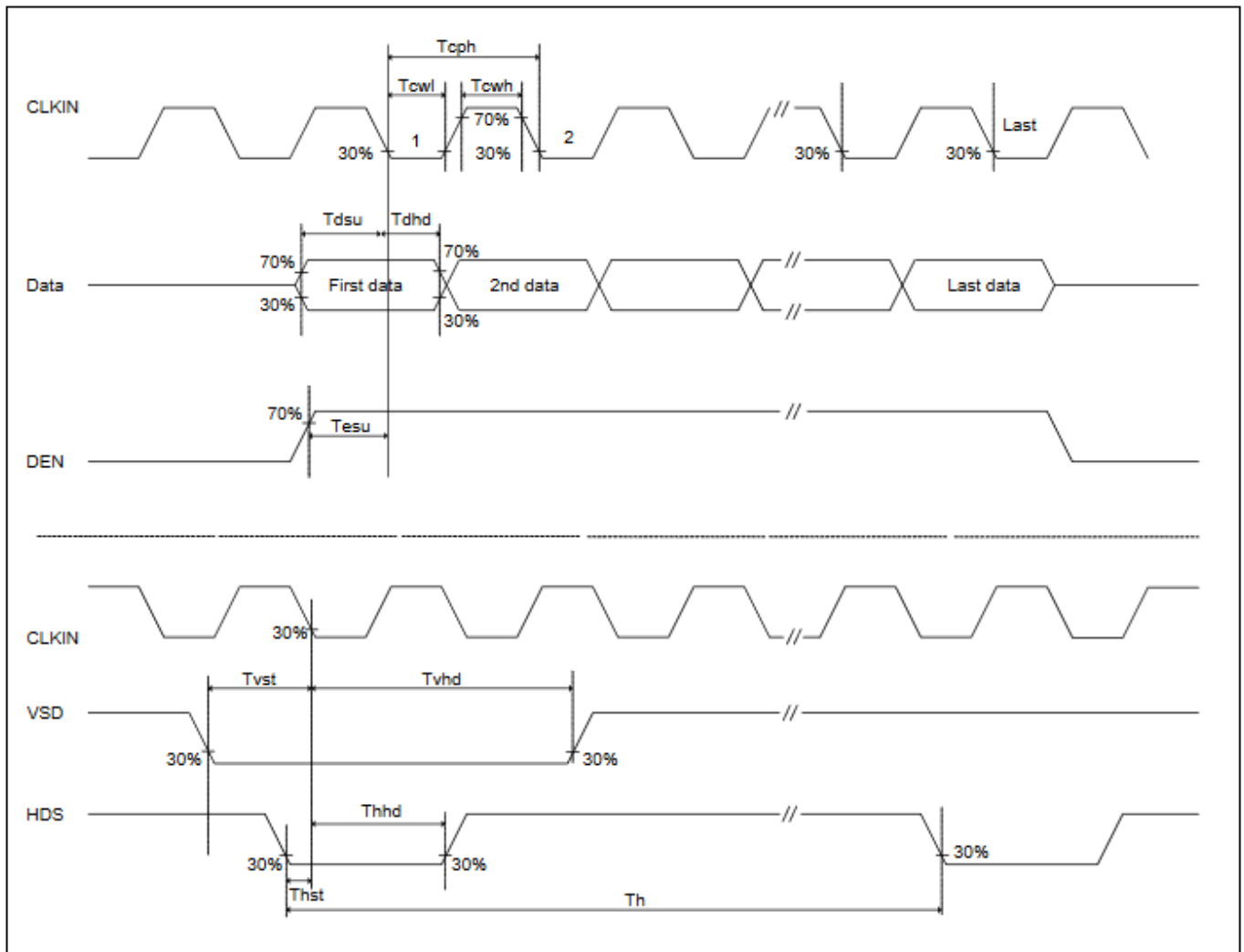

Figure 6.3: Clock and Data Input Timing Diagram

## **7. Cautions and Handling Precautions**

### **7.1 Handling and Operating the Module**

1. When the module is assembled, it should be attached to the system firmly. Do not warp or twist the module during assembly work.
2. Protect the module from physical shock or any force. In addition to damage, this may cause improper operation or damage to the module and back-light unit.
3. Note that polarizer is very fragile and could be easily damaged. Do not press or scratch the surface.
4. Do not allow drops of water or chemicals to remain on the display surface. If you have the droplets for a long time, staining and discoloration may occur.
5. If the surface of the polarizer is dirty, clean it using some absorbent cotton or soft cloth.
6. The desirable cleaners are water, IPA (Isopropyl Alcohol) or Hexane. Do not use ketene type materials (ex. Acetone), Ethyl alcohol, Toluene, Ethyl acid or Methyl chloride. It might permanent damage to the polarizer due to chemical reaction.
7. If the liquid crystal material leaks from the panel, it should be kept away from the eyes or mouth. In case of contact with hands, legs, or clothes, it must be washed away thoroughly with soap.
8. Protect the module from static; it may cause damage to the CMOS ICs.
9. Use fingerstalls with soft gloves in order to keep display clean during the incoming inspection and assembly process.
10. Do not disassemble the module.
11. Protection film for polarizer on the module shall be slowly peeled off just before use so that the electrostatic charge can be minimized.
12. Pins of I/F connector shall not be touched directly with bare hands.
13. Do not connect, disconnect the module in the “Power ON” condition.
14. Power supply should always be turned on/off by the item Power On Sequence & Power Off Sequence

### **7.2 Storage and Transportation.**

1. Do not leave the panel in high temperature, and high humidity for a long time. It is highly recommended to store the module with temperature from 0 to 35 °C and relative humidity of less than 70%
2. Do not store the TFT-LCD module in direct sunlight.
3. The module shall be stored in a dark place. When storing the modules for a long time, be sure to adopt effective measures for protecting the modules from strong ultraviolet radiation, sunlight, or fluorescent light.
4. It is recommended that the modules should be stored under a condition where no condensation is allowed. Formation of dewdrops may cause an abnormal operation or a failure of the module. In particular, the greatest possible care should be taken to prevent any module from being operated where condensation has occurred inside.
5. This panel has its circuitry FPC on the bottom side and should be handled carefully in order not to be stressed.