



EV6543HA-L-00A

3V to 22V, Three-Phase Brushless DC Motor Driver Evaluation Board

DESCRIPTION

The EV6543HA-L-00A is an evaluation board for the MP6543HGL-A, a three-phase brushless DC motor driver.

The EV6543HA-L-00A operates from a maximum 22V supply voltage. It integrates three half-bridges consisting of six N-channel power MOSFETs. The rotor position information is provided by the Hall sensors assembled in the motor, and the driving control signals are generated by an external controller, such as an MCU or FPGA.

ELECTRICAL SPECIFICATIONS

Parameter	Symbol	Value	Units
Input voltage	V_{IN}	3 to 22	V
LDO input voltage	V_{IN_LDO}	3 to 22	V
VREF voltage	V_{REF}	3.3	V
VCC voltage	V_{CC}	3.3	V

FEATURES

- Wide 3V to 22V Input Voltage Range
- Built-In 3.3V, 100mA LDO Regulator
- Integrated Bidirectional Current-Sense Amplifiers
- Supports 100% Duty Cycle Operation
- Low-Side/High-Side Logic Input
- Over-Current Protection (OCP), Over-Temperature Protection (OTP)
- Fault Indication Output

APPLICATIONS

- Three-Phase Brushless DC Motors and Permanent Magnet Synchronous Motors
- Drones
- Robotics

All MPS parts are lead-free, halogen-free, and adhere to the RoHS directive. For MPS green status, please visit the MPS website under Quality Assurance. "MPS", the MPS logo, and "Simple, Easy Solutions" are trademarks of Monolithic Power Systems, Inc. or its subsidiaries.

EV6543HA-L-00A EVALUATION BOARD



(LxW) 6.35cmx6.35cm

Board Number	MPS IC Number
EV6543HA-L-00A	MP6543HGL-A

QUICK START GUIDE

1. Attach the input voltage ($3V \leq V_{IN} \leq 22V$) to the VIN connector, and attach the input ground to the GND connector.
2. Attach the LDO input voltage ($3V \leq V_{IN_LDO} \leq 22V$) to the VIN_LDO connector, and attach the input ground to the GND connector.
3. Attach a 3.3V constant voltage to the VCC connector and switch SW1 to position 1 (top side) to enable the chip.
4. Attach a 3.3V constant voltage to the VREF connector to set the current-sense output reference voltage.
5. Attach the motor's Hall signals to the Hall sensor connector.
6. Attach the driving control signals generated by the external controller to the CN1 connector.

EVALUATION BOARD SCHEMATIC

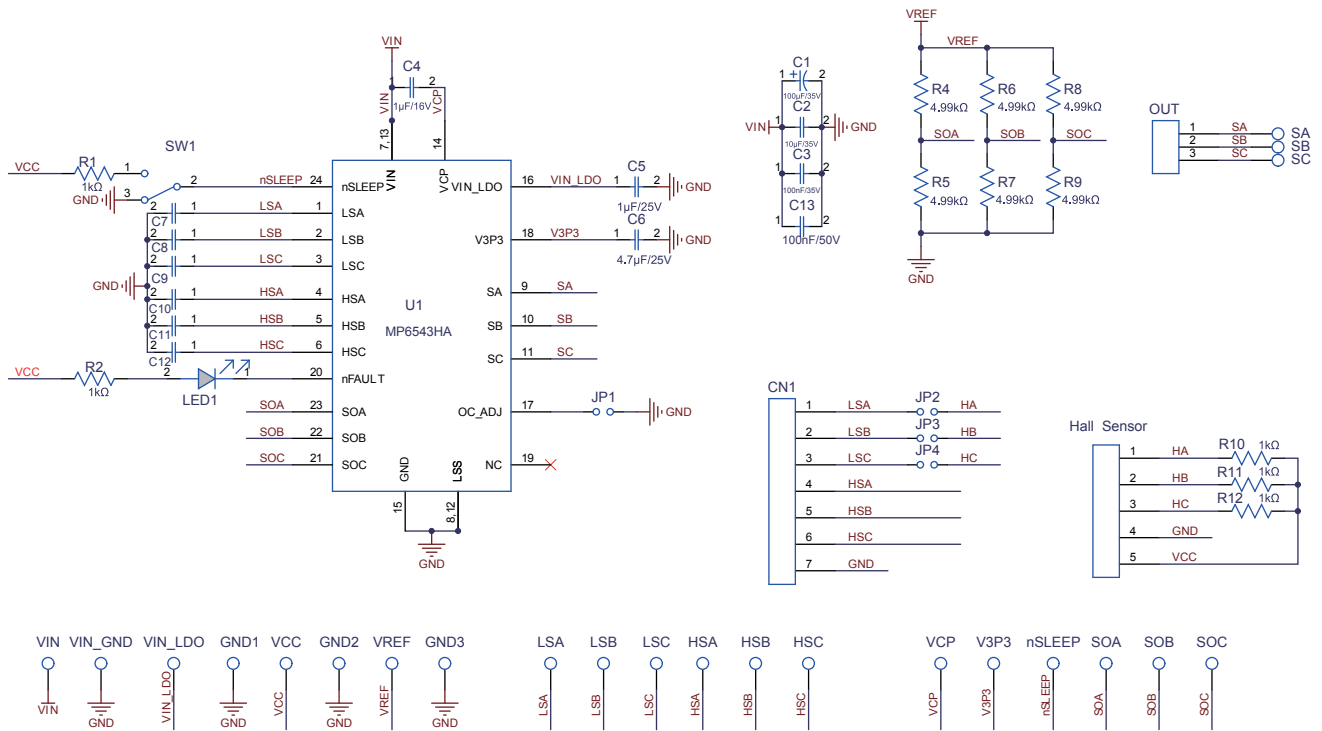

Figure 1: Evaluation Board Schematic

EV6543HA-L-00A BILL OF MATERIALS

Qty	Ref	Value	Description	Package	Manufacturer	Part Number
5	R1, R2, R10, R11, R12	1kΩ	Film resistor, 1%	0603	Yageo	RC0603FR-071KL
6	R4, R5, R6, R7, R8, R9	4.99kΩ	Film resistor, 1%	0603	Yageo	RC0603FR-074K99L
1	C1	100μF	Electrolytic capacitor, 35V	DIP	Jianghai	CD287-35V100
1	C2	10μF	Ceramic capacitor, 35V, X7R	1210	Murata	GRM32ER7YA106KA12L
2	C3, C13	100nF	Ceramic capacitor, 50V, X7R	0603	Würth	885012206095
1	C4	1μF	Ceramic capacitor, 16V, X7R	0603	Würth	885012206052
1	C5	1μF	Ceramic capacitor, 25V, X5R	0603	Würth	885012106022
1	C6	4.7μF	Ceramic capacitor, 25V, X5R	0603	Murata	GRM188R61E475KE11D
6	C7, C8, C9, C10, C11, C12	NS				
1	LED1	Red	LED	0805	Baihong	BL-HUE35A-AV-TRB
1	U1	22V, 2A	Three-phase brushless DC motor driver	QFN24 (3mmx4mm)	MPS	MP6543HGL-A
1	SW1	SPDT	Button	DIP	Würth	450301014042
4	JP1, JP2, JP3, JP4	2-bits/ 2.54mm	Connector	DIP	Electrical market	61304011121
1	JP1	2-bits/ 2.54mm	Short jumper	DIP	Electrical market	60900213421
1	CN1	7-bits/ 2.54mm	Connector	DIP	Electrical market	61304011121
1	Hall sensor	5-bits/ 2.54mm	Connector	DIP	Electrical market	61304011121
1	PWMA, PWMB, PWMC, ENA, ENB, ENC	6-bits/ 2.54mm	Connector	DIP	Electrical market	61304011121
1	OUT	3-bits/ 2.54mm	Connector	DIP	Electrical market	61304011121
6	VCP, V3P3, SOA, SOB, SOC, NSLEEP	Yellow	Test point	DIP	Electrical market	Test point
2	VIN, VIN_GND	Φ = 2mm	Connector	DIP	Electrical market	Φ = 2mm Needle
9	VIN_LDO, VREF, VCC, GND, GND, GND, SA, SB, SC	Φ = 1mm	Connector	DIP	Electrical market	Φ = 1mm Needle

PCB LAYOUT

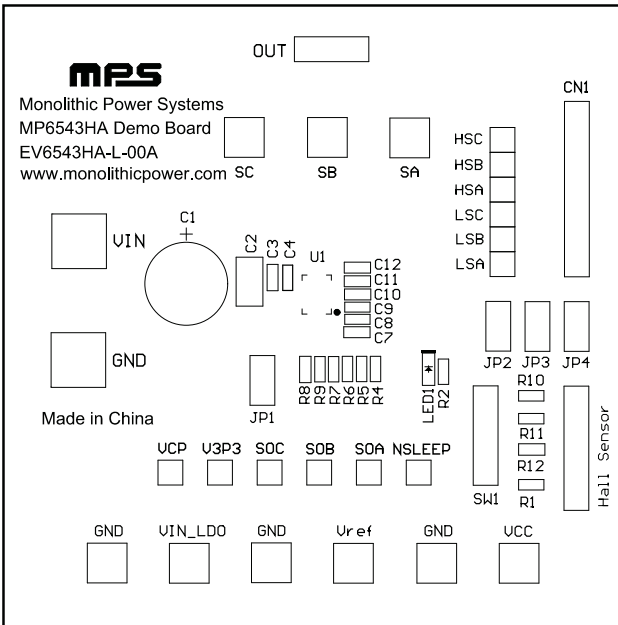

Figure 2: Top Silk Layer

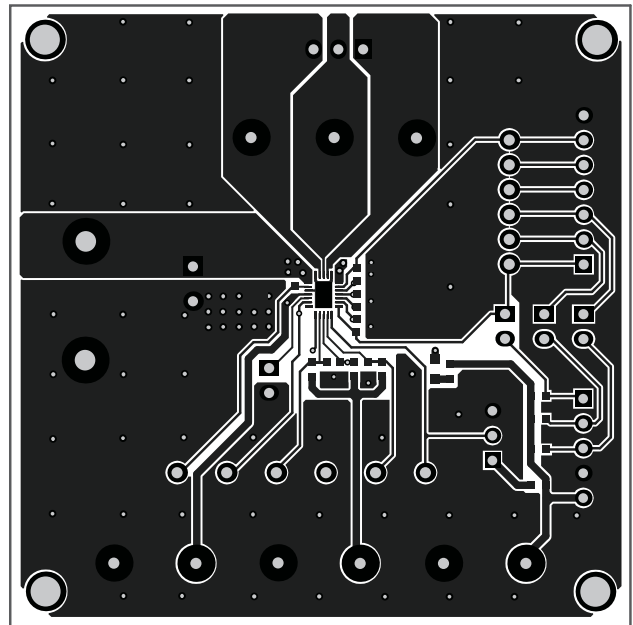

Figure 3: Top Layer

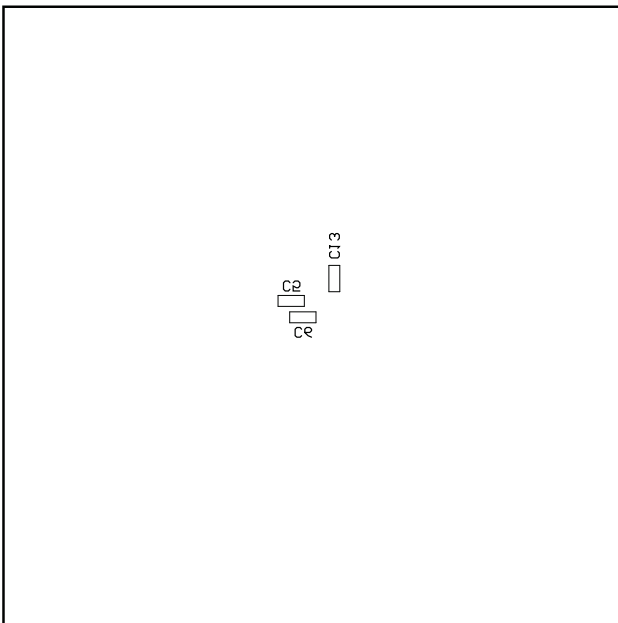

Figure 4: Bottom Silk Layer

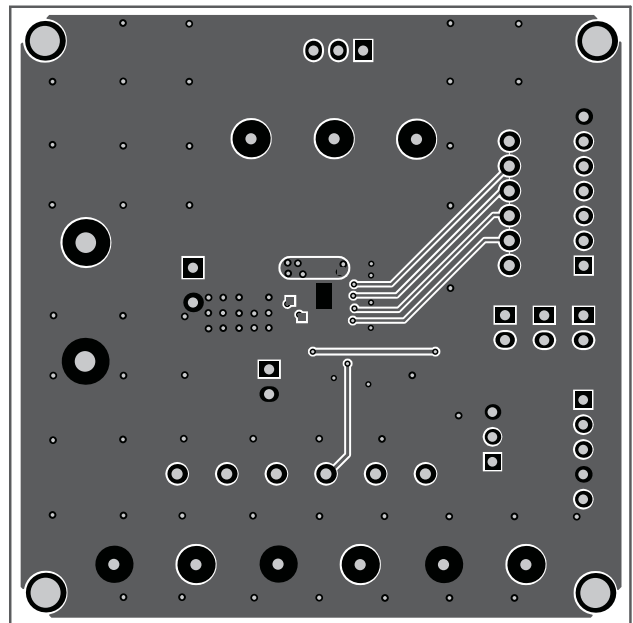

Figure 5: Bottom Layer

Notice: The information in this document is subject to change without notice. Please contact MPS for current specifications. Users should warrant and guarantee that third-party Intellectual Property rights are not infringed upon when integrating MPS products into any application. MPS will not assume any legal responsibility for any said applications.