

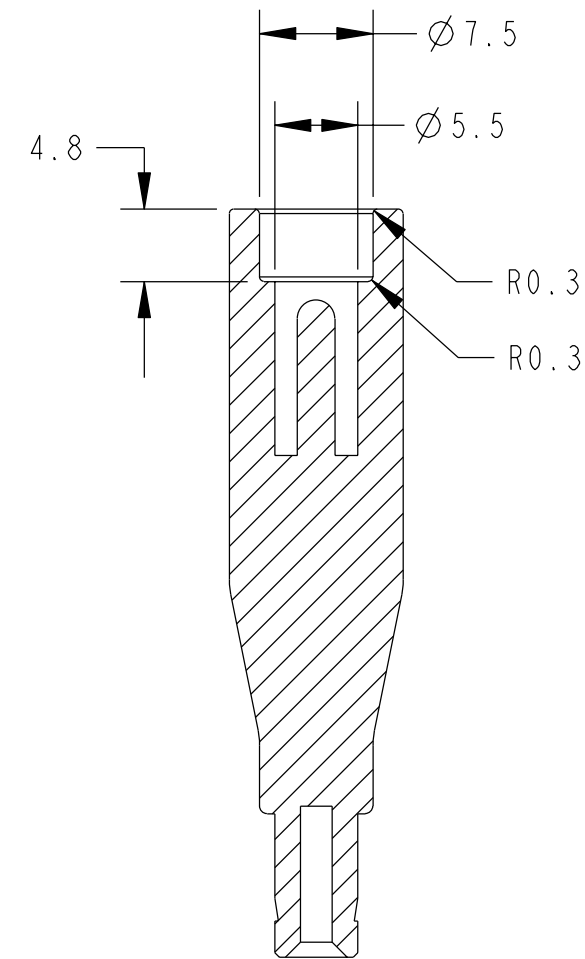

REVISIONS			
REV	DESCRIPTION	DATE	APPROVAL
A	RELEASE	25-Feb-03	X

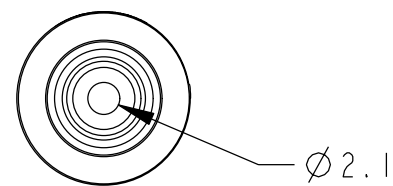

SECTION B-B

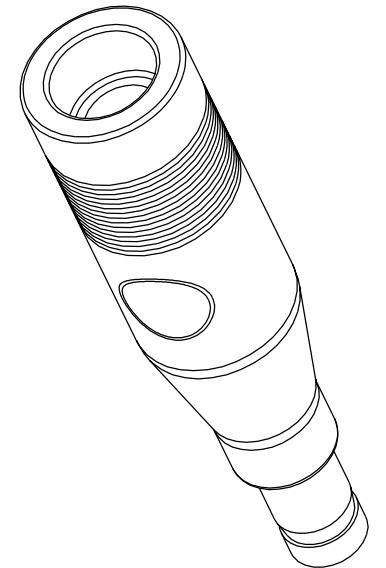

NOTES:
 ADAPTER: #2
 DC PLUG: Ø2.1 X 5.5 X 9.5 MM (BLACK)
 DC JACK: Ø2.5 X 5.5 X 9.5 MM
 MATERIAL: PVC 90 "A"
 ADAPTER DESIGNED BY AULT FOR USE ONLY WITH CABLE OVERMOLD TOOLING 6131450 AND 6131451 WITH BARREL LENGTH .375 (9.5 MM). WITHDRAW TEST APPROX. 1 KG ~ 2 LBS. PER 1 MINUTE.
 MANUFACTURED BY GOOD POWER P/N AD-228 #2.

TOLERANCES UNLESS NOTED OTHERWISE	SUPPLEMENTARY INFORMATION FIRST USED X		AULT ADAPTER (JACK #3 PLUG #2)		 AULT <small>AULT INCORPORATED MINNEAPOLIS, MINNESOTA</small>	
	DO NOT SCALE DRAWING					
.X ±.020 .XX ±.010 .XXX ±.005 ANGLES ±.5°	DRAWN BY	S. JOHNSON	25-Feb-03	SIZE	DRAWING NO.	REV
	DESIGNER			B	6872340FG	A
	AGENCY					
	ENGINEER					
APPROVED				SCALE 2.000	SHEET 1 OF 1	